

**Coral Springs
Improvement District**

Agenda

August 19, 2019



Coral Springs Improvement District

August 12, 2019

Board of Supervisors
Coral Springs Improvement District

Dear Board Members:

The regular meeting of the Board of Supervisors of the Coral Springs Improvement District will be held on August 19, 2019 at 4:00 p.m. at the District Offices, 10300 NW 11th Manor, Coral Springs, Florida. Following is the advance agenda for the meeting.

1. Roll Call
2. Acceptance of the June 17, 2019 Landowners Meeting and Approval of the June 17, 2019 Regular Meeting
3. Resolution 2019-4, Canvassing and Certifying the Results of the Landowners' Election
4. Audience Comments
5. Approval of Financial Statements for July 2019
6. Consideration of Permits
 - A. Permit 2019-2, MCI Metro for the Installation of Fiber Optic Cable Route at Pine Trails Park
 - B. Permit 2019-4, Pillar Consultants for Proposed Development of Multi Family Units at NW 94th Avenue
7. Public Hearing to Consider Adoption of General Fund Budget for Fiscal Year 2020
 - A. Resolution 2019-6, Adopting the General Fund Budget
 - B. Resolution 2019-7, Levying Non Ad Valorem Assessments
8. Consideration of Resolution 2019-8, Approving the Proposed Water and Sewer Budget and Setting the Public Hearing
9. Consideration of Encroachment Agreement with 8137 NW 2nd Manor
10. Emergency Work by Globaltech
 - A. Automatic Transfer Switch Evaluation and Installation
 - B. Emergency Installation of High Service Pumping System
11. Consideration of Work Authorizations
 - A. Amendment #1 to Work Authorization #149 for HSP Building Valve Replacement for an Increase of \$34,568
 - B. Amendment #1 to Work Authorization #152 for Membrane Plant ORP Analyzer for a Decrease of \$2,000
 - C. Work Authorization #162 for WTP Well No. 9 Control Panel Replacement for a Total Job Price of \$96,999
 - D. Work Authorization #163 for Production Well 5 Re-Development for a Total Cost of \$94,500
12. Consideration Wellfield Maintenance Contract with AMPS, Piggybacking Off of the City of Sunrise
13. Consideration of Resolution 2019-9, Adopting Code of Ethics
14. Consideration of Resolution 2019-10, Approving Statewide Mutual Aid Agreement
15. Consideration of agreement with BSI Online for Backflow Program
16. Discussion and Approval of Purchases from Xylem Water Solutions as a Sole Source Supplier of Flygt Pumps and Parts for the Drainage Lift Stations

Coral Springs Improvement District

17. Consideration of Purchase of Two Portable Generators from Doosan, Piggybacking Off the Florida Sheriffs Association and Florida Association of Counties
18. Ratification of Water and Sewer Standards
19. Proposal for ADA Compliant Website
20. Staff Reports
 - A. Manager – Ken Cassel
 - Proposed Meeting Schedule for Fiscal Year 2020
 - B. Engineer – Rick Olson
 - C. Department Reports
 - Operations – Dan Daly
 - Utility Billing Work Orders
 - Utilities Update (David McIntosh)
 - Water – Joe Stephens (Report Included)
 - Wastewater – Kenneth Miller (Report Included)
 - Stormwater – Shawn Frankenhauser (Report Included)
 - Field – Curt Dwiggin (Report Included)
 - Maintenance Report – Pedro Vasquez (Report Included)
 - Human Resources – Jan Zilmer
 - Motion to Accept Department Reports
 - D. Attorney
21. Supervisors' Requests
22. Adjournment

Any supporting documents not included in the agenda package will be distributed at the meeting. If you have any questions prior to the meeting, please contact me.

Sincerely,

Kenneth Cassel/sd
District Manager

cc: District Staff
Terry Lewis
Seth Behn
Rick Olson
Beverley Servé
Stephen Bloom

Second Order of Business

**MINUTES OF LANDOWNERS' MEETING
CORAL SPRINGS
IMPROVEMENT DISTRICT**

The Landowners' Meeting of the Coral Springs Improvement District was held Monday, June 17, 2019 at 4:00 p.m. at the District Office, located at 10300 NW 11th Manor, Coral Springs, Florida.

Present were:

Dr. Martin Shank
Duane Holland
Len Okyn
Nick St. Cavish
Kenneth Cassel
Terry Lewis
Seth Behn
Dan Daly
David McIntosh
Jan Zilmer
Marta Rubio
Rick Olson
Curt Duggins
Joe Stephens
Shawn Frankenhauser
Pedro Vasquez
Raquel Holland
Sandra Demarco

FIRST ORDER OF BUSINESS

Call to Order

Mr. Cassel called the landowners' meeting to order.

THIRD ORDER OF BUSINESS

**Election of a Chairman for the
Purpose of Conducting the
Landowners' Meeting**

Mr. Lewis served as Chairman for the purpose of conducting the landowners' meeting.

SECOND ORDER OF BUSINESS

**Determination of the Number of
Voting Units Represented**

Each landowner owns one-quarter of an acre of land.

FOURTH ORDER OF BUSINESS

Nominations for the Positions of Supervisors (3)

The three nominees are as follows:

- Martin Shank
- Duane Holland
- Len Okyn

FIFTH ORDER OF BUSINESS

Casting of Ballots

Ballots were cast.

SIXTH ORDER OF BUSINESS

Ballot Tabulation

Proxies and ballots were just received and shall be tabulated and certified within the next week.

Mr. Cassel being a Notary Public of the State of Florida, administered the Oath of Office to Dr. Shank, Mr. Holland and Mr. Okyn; copies of the signed Oaths are attached hereto and made a part of the public record.

SEVENTH ORDER OF BUSINESS

Landowners' Questions or Comments

Hearing no questions or comments from landowners', the next order of business followed.

EIGHTH ORDER OF BUSINESS

Adjournment

There being no further business,

On MOTION by Mr. Holland seconded by Dr. Shank, with all in favor, the landowners' meeting was adjourned.

**MINUTES OF MEETING
CORAL SPRINGS
IMPROVEMENT DISTRICT**

The regular meeting of the Board of Supervisors of the Coral Springs Improvement District was held Monday, June 17, 2019, immediately following the landowners' meeting at the District Office, located at 10300 NW 11th Manor, Coral Springs, Florida.

Present and constituting a quorum were:

Dr. Martin Shank	President
Duane Holland	Vice President
Len Okyn	Secretary

Also present were:

Kenneth Cassel	District Manager
Terry Lewis	District Counsel
Seth Behn	Lewis Longman & Associates
Dan Daly	Director of Operations
David McIntosh	Director of Utilities
Jan Zilmer	Human Resources
Marta Rubio	District Accountant
Rick Olson	District Engineer
Curt Dwiggin	Field Department
Joe Stephens	Water Department
Shawn Frankenhauser	Stormwater Department
Pedro Vasquez	Maintenance Department
Sandra Demarco	Inframark, LLC
Nick St. Cavish	Former Board Member
Raquel Holland	Resident

The following is a summary of the discussions and actions taken at the June 17, 2019 Coral Springs Improvement District's Board of Supervisors Meeting.

FIRST ORDER OF BUSINESS

Roll Call

Mr. Cassel called the meeting to order.

- Mr. St. Cavish thanked the Board, Mr. Cassel and staff for all their help during his time as a Board member.

FIFTH ORDER OF BUSINESS

Approval of Financial Statements for May 2019

The Board reviewed the financial statements for May 2019.

- It appears a large amount of the assessments have not been paid.
- Mr. Okyn was advised to meet with Ms. Rubio regarding budgets.

SIXTH ORDER OF BUSINESS

Consideration of Change Order #1 with Trio Development for an Increase of \$29,950

Mr. Dwiggins presented this item for the Board’s review and approval.

- The valve pit lid needs to be replaced on Lift Station #14.

On MOTION by Mr. Holland, seconded by Dr. Shank, with all in favor, Change Order #1 with Trio Development for an increase of \$29,950, was approved.

FIFTH ORDER OF BUSINESS

Approval of Financial Statements for May 2019 (Continued)

On MOTION by Mr. Holland, seconded by Dr. Shank, with all in favor, the Financial Statements for May 2019 were approved.

SEVENTH ORDER OF BUSINESS

Consideration of Bulk Chemical Contract Renewal for the Water Plant (Two Options)

- Mr. Stephens presented this item for the Board’s review and approval.
- Some costs increased.
- They will lock in the price for one year, which will continue into the second year if these prices are still available.

On MOTION by Mr. Holland, seconded by Dr. Shank, with all in favor, renewal of the bulk chemical contract with Hawkins for the water plant was approved, as discussed.

EIGHTH ORDER OF BUSINESS

Staff Reports

A. Manager – Ken Cassel

Mr. Cassel reminded the Board of the June 25, 2019 special meeting and attorney/client session.

B. Engineer – Rick Olson

Mr. Olson reviewed his monthly status report; a copy of which is attached hereto and made part of the public record.

- The subcontractor for Work Authorization #133 chose not to perform four of the wells due to the wording of the contract. The four wells will be taken care of at the engineer's expense.

C. Department Reports

- **Operations – Dan Daly**
 - **Utility Billing Work Orders**

This item is for information only. ADA compliance for the website was also discussed.

- **Utilities Update (David McIntosh)**

Mr. McIntosh discussed the FASD Conference he recently attended. He continues to respond to requests for information from FEMA for the debris removal.

- **Water – Joe Stephens (Report Included)**

A copy of the report was included in the agenda package and is attached hereto as part of the public record. Mr. Stephens attended the 2019 Desalting Association Symposium in which CSID won "Membrane Plant of the Year." There will be an article in the next newsletter.

- **Wastewater – Kenneth Miller (Report Included)**

A copy of the report was included in the agenda package and is attached hereto as part of the public record.

- **Stormwater – Shawn Frankenhauser (Report Included)**

A copy of the report was included in the agenda package and is attached hereto as part of the public record. A resident's installation of a deck on the canal bank was discussed.

- **Field – Curt Dwiggin (Report Included)**

A copy of the report was included in the agenda package and is attached hereto as part of the public record.

- **Maintenance Report – Pedro Vasquez (Report Included)**

A copy of the report was included in the agenda package and is attached hereto as part of the public record.

- **Human Resources – Jan Zilmer**

Mr. Zilmer reported he is looking into health insurance. The review process will commence in September.

- **Motion to Accept Department Reports**

On MOTION by Mr. Holland, seconded by Dr. Shank, with all in favor, the Department Reports were accepted.

D. Attorney

Mr. Lewis discussed preliminary rulings regarding ADA issues.

NINTH ORDER OF BUSINESS

Supervisors’ Requests

- Mr. Holland discussed the plants being able to withstand category three hurricanes. Mr. McIntosh stated Globaltech is working on an updated hurricane report.
- Mr. Okyn commented on the award the District won and congratulated staff.

TENTH ORDER OF BUSINESS

Adjournment

There being no further business,

On MOTION by Mr. Holland, seconded by Dr. Shank, with all in favor, the meeting was adjourned at approximately 5:18 p.m.

Kenneth Cassel
Assistant Secretary

Dr. Martin Shank
President

Third Order of Business

RESOLUTION 2019-4

A RESOLUTION CANVASSING AND CERTIFYING THE RESULTS OF THE LANDOWNERS ELECTION OF SUPERVISORS HELD PURSUANT TO CHAPTER 2004-469

WHEREAS, pursuant to Section 5 of Chapter 2004-469, Laws of Florida, a landowners meeting is required to be held every four years following the creation of a Special District for the purpose of electing three Supervisors to the Board of Supervisors of the District; and

WHEREAS, following proper publication of notice thereof, such landowners meeting was held June 17, 2019, at which the below recited persons were duly elected by virtue of the votes cast in his favor; and

WHEREAS, this resolution canvasses the votes, and declares and certifies the results of said election;

NOW, THEREFORE, BE IT RESOLVED BY THE BOARD OF SUPERVISORS OF THE CORAL SPRINGS IMPROVEMENT DISTRICT;

1. The following persons are found, certified, and declared to have been duly elected as a Supervisor of and for the District, having been elected by the votes cast in his favor as shown, to wit:

Martin Shank	238	Votes
Duane Holland	238	Votes
Len Okyn	238	Votes

2. In accordance with said statute, and by virtue of the number of votes cast for each Supervisor, and is declared to have been elected for the following terms of office:

Martin Shank	four (4) year term
Duane Holland	four (4) year term
Len Okyn	four (4) year term

3. Said term of office shall commence immediately upon the adoption of this Resolution.

PASSED AND ADOPTED THIS 19TH DAY OF AUGUST, 2019.

Dr. Martin Shank, President

Kenneth Cassel Assistant Secretary

Fifth Order of Business

CORAL SPRINGS IMPROVEMENT DISTRICT

FINANCIAL REPORTING – MEETING AUGUST 19, 2019

CORAL SPRINGS IMPROVEMENT DISTRICT

FINANCIAL REPORTING FOR JULY 2019

AUGUST 19, 2019

Board of Supervisors Meeting

**CORAL SPRINGS IMPROVEMENT DISTRICT
BALANCE SHEET
All Fund Types and Account Groups**

JULY 31, 2019

DESCRIPTION	GENERAL FUND	WATER & SEWER FUND	GENERAL FIXED ASSETS	TOTALS
ASSETS				
Cash & Cash Equivalents				
Checking Accounts	\$ 351,738	1,299,763	\$ -	\$ 1,651,501
CDAR'S	2,000,000	2,000,000	-	4,000,000
CD'S & Money Market Accounts	2,145,542	7,309,054	-	9,454,596
Investments	2,521,437	7,442,399	-	9,963,836
Restricted Investments	-	4,394,630	-	4,394,630
Accounts Receivable	-	683,095	-	683,095
Accrued Interest Receivable	-	51,886	-	51,886
Unbilled Utility Revenues Receivable	-	767,049	-	767,049
Due from Other Funds	547	-	-	547
Prepaid Expenses	4,406	40,046	-	44,452
Deferred Outflow-2007 Series	-	1,592,775	-	1,592,775
Land	-	361,739	553,200	914,939
Easements	-	394,998	-	394,998
Meters in Field (Net)	-	1,051,699	-	1,051,699
Machinery & Equipment (Net)	-	363,405	155,242	518,647
Imp. Other than Bldgs. (Net)	-	51,191,976	6,242,174	57,434,150
Buildings (Net)	-	146,993	-	146,993
Construction in Progress	-	2,398,780	-	2,398,780
TOTAL ASSETS	\$ 7,023,670	\$ 81,490,287	\$ 6,950,616	\$ 95,464,573

**CORAL SPRINGS IMPROVEMENT DISTRICT
BALANCE SHEET
All Fund Types and Account Groups**

JULY 31, 2019

DESCRIPTION	GENERAL FUND	WATER & SEWER FUND	GENERAL FIXED ASSETS	TOTALS
LIABILITIES				
Accounts Payable	\$ -	\$ -	\$ -	\$ -
Contracts Payable	-	-	-	-
Retainage Payable	-	-	-	-
Accrued Int Payable-2016 Series	-	204,408	-	204,408
Accrued Wages Payable	-	-	-	-
Accrued Vac/Sick Time Payable	-	236,396	-	236,396
Pension Payable	-	-	-	-
Utility Tax Payable	-	52,859	-	52,859
Payroll Taxes Payable	-	-	-	-
Deposits	77,357	554,895	-	632,252
Deferred Revenues	-	-	-	-
Due to Other Funds	-	547	-	547
Net OPEB Obligation	-	99,348	-	99,348
Bonds Payable-2016 Series	-	38,615,000	-	38,615,000
TOTAL LIABILITIES	\$ 77,357	\$ 39,763,453	\$ -	\$ 39,840,810
FUND BALANCE / NET POSITION				
Fund Balance:				
Unspendable	4,406		-	4,406
Assigned	3,584,166		-	3,584,166
Unassigned	3,357,741	-	-	3,357,741
Net Position	-	41,726,834	-	41,726,834
Investment in GF	-	-	6,950,616	6,950,616
TOTAL FUND BALANCE/ NET ASSETS	\$ 6,946,313	\$ 41,726,834	\$ 6,950,616	\$ 55,623,763
TOTAL LIABILITIES & FUND BALANCE	\$ 7,023,670	\$ 81,490,287	\$ 6,950,616	\$ 95,464,573

**CORAL SPRINGS IMPROVEMENT DISTRICT
GENERAL FUND**

Statement of Revenues, Expenditures and Change in Fund Balance

For the Period Ending July 31, 2019

	ADOPTED BUDGET FY 2018-2019	PRORATED BUDGET THRU 7/31/2019	ACTUAL 10 MONTHS ENDING 7/31/2019	VARIANCE FAVORABLE (UNFAVORABLE)
REVENUES				
Assessments (Net) (*)	\$ 3,849,956	\$ 3,386,483	\$ 3,386,483	\$ -
Permit Review Fees	1,000	833	2,400	1,567
Interest Income	20,000	16,667	81,792	65,125
Shared Personnel Revenue	33,896	28,246	28,246	-
Miscellaneous Revenue	-	-	8,746	8,746
FEMA Reimbursement	-	-	67,517	67,517
Carry Forward Assigned Funds (*)	92,885	-	-	-
TOTAL REVENUES	\$ 3,997,737	\$ 3,432,229	\$ 3,575,184	\$ 142,955
EXPENDITURES				
ADMINISTRATIVE				
Supervisor Fees	\$ 7,200	\$ 6,000	\$ 6,000	\$ -
Salaries/Wages	133,908	113,307	111,357	1,950
Special Pay (*)	238	238	238	-
FICA Taxes	10,796	9,135	9,006	129
Pension Expense	16,069	13,597	13,663	(66)
Health Insurance	54,611	45,509	44,251	1,258
Workers Comp. Ins.	379	316	443	(127)
Engineering Fees (*)	30,000	25,000	23,188	1,812
Legal Fees	60,000	50,000	49,666	334
Special Consulting Services	100,000	83,333	70,793	12,540
Annual Audit (*)	10,500	8,000	8,000	-
Actuarial Computation-OPEB	2,772	2,310	-	2,310
Management Fees	57,313	47,761	47,761	-
Telephone Expense	3,334	2,778	2,778	-
Postage	668	556	556	-
Printing & Binding	1,260	1,050	1,050	-
Administrative Building Cost	12,000	10,000	10,000	-
Insurance	1,179	983	680	303
Legal Advertising	2,000	1,667	267	1,400
Contingencies/Other Current Charges	1,000	833	524	309
Paver Incentive Program	12,500	10,417	-	10,417
Computer Expense/Technology	29,400	24,500	21,411	3,089
Digital Record Management	1,000	833	68	765
Office Supplies	7,125	5,938	5,974	(36)
Dues, Licenses, Schools & Permits	7,800	6,500	5,868	632
Promotional Expenses (*)	8,400	7,000	1,964	5,036
Capital Purchases (*)	-	-	-	-
TOTAL ADMINISTRATIVE	\$ 571,452	\$ 477,561	\$ 435,506	\$ 42,055

**CORAL SPRINGS IMPROVEMENT DISTRICT
GENERAL FUND**

Statement of Revenues, Expenditures and Change in Fund Balance

For the Period Ending July 31, 2019

	ADOPTED BUDGET FY 2018-2019	PRORATED BUDGET THRU 7/31/2019	ACTUAL 10 MONTHS ENDING 7/31/2019	VARIANCE FAVORABLE (UNFAVORABLE)
FIELD OPERATIONS				
Salaries and Wages	\$ 278,553	\$ 235,699	\$ 219,649	\$ 16,050
Special Pay (*)	813	813	813	-
FICA Taxes	21,309	18,031	16,613	1,418
Pension Expense	33,426	28,284	26,364	1,920
Health Insurance	88,849	74,041	74,673	(632)
Worker's Comp. Insurance	15,433	12,861	12,749	112
Water Quality Testing	3,000	2,500	1,619	881
Communications-Radios/Cellphones	1,872	1,560	855	705
Electric	1,411	1,176	512	664
Rentals & Leases	-	-	-	-
Insurance	14,845	12,371	8,160	4,211
R & M - General	54,010	45,008	48,020	(3,012)
R & M - Culvert Inspection & Cleaning	69,500	57,917	129,000	(71,083)
R & M - Canal Dredging & Maintenance	25,000	20,833	-	20,833
R & M - Vegetation Management	15,000	12,500	4,630	7,870
Operating Supplies - General	3,825	3,188	1,528	1,660
Operating Supplies - Chemicals	114,659	95,549	75,660	19,889
Operating Supplies - Uniform	1,823	1,519	1,211	308
Operating Supplies - Motor Fuels	51,705	43,088	6,064	37,024
Dues, Licenses, Schools & Permits	3,752	3,127	1,722	1,405
Capital Outlay-Equipment (*)	27,500	22,917	-	22,917
Capital Improvements (*)	1,000,000	833,333	373,352	459,981
TOTAL FIELD	\$ 1,826,285	\$ 1,526,315	\$ 1,003,194	\$ 523,121
TOTAL EXPENDITURES	\$ 2,397,737	\$ 2,003,876	\$ 1,438,700	\$ 565,176
RESERVES				
Reserved for 1st Qtr. Operating	350,000	291,667	-	291,667
Reserved for Projects & Emergencies	250,000	208,333	-	208,333
Storm Damages Reserves	1,000,000	833,333	-	833,333
TOTAL RESERVES	\$ 1,600,000	\$ 1,333,333	\$ -	\$ 1,333,333
TOTAL EXPENDITURES & RESERVES	\$ 3,997,737	\$ 3,337,209	\$ 1,438,700	\$ 1,898,509
EXCESS REVENUES OVER (UNDER)				
EXPENDITURES & RESERVES	\$ -		\$ 2,136,484	
FUND BALANCE BEGINNING			\$ 4,809,829	
FUND BALANCE ENDING			\$ 6,946,313	

(*) Not prorated figures

**CORAL SPRINGS IMPROVEMENT DISTRICT
WATER & SEWER FUND
Statement of Revenues, Expenses and Change in Net Assets
For the Period Ending July 31, 2019**

	ADOPTED BUDGET FY 2018-2019	PRORATED BUDGET THRU 7/31/2019	ACTUAL 10 MONTHS ENDING 7/31/2019	VARIANCE FAVORABLE (UNFAVORABLE)
REVENUES				
Water Revenue	\$ 6,467,008	5,389,173	\$ 5,474,042	\$ 84,869
Sewer Revenue	5,852,977	4,877,481	4,864,595	(12,886)
Standby Revenue	3,120	2,600	2,560	(40)
Processing Fees	12,000	10,000	14,200	4,200
Lien Information Fees	9,000	7,500	14,425	6,925
Delinquent Fees	290,000	241,667	261,400	19,733
Contract Utility Billing Services	59,620	49,684	49,684	-
Contract HR & Payroll Services	12,902	10,752	10,752	-
Facility Connection Fees	-	-	28,280	28,280
Meter Fees	-	-	5,592	5,592
Line Connection Fees	-	-	21,700	21,700
Interest Income-Restricted	-	-	95,710	95,710
Interest Income-Operations	65,000	54,167	275,162	220,995
Rent Revenue	63,304	52,753	76,622	23,869
Technology Sharing Revenue	15,000	12,500	12,500	-
Misc. Revenues	12,000	10,000	29,563	19,563
Renewal & Replacement (*)	365,000	-	-	-
Carryforward Prior Yr. Fund Balance (*)	4,372,639	1,285,723	1,285,723	-
TOTAL REVENUES	\$ 17,599,570	\$ 12,004,000	\$ 12,522,510	\$ 518,510

**CORAL SPRINGS IMPROVEMENT DISTRICT
WATER & SEWER FUND
Statement of Revenues, Expenses and Change in Net Assets
For the Period Ending July 31, 2019**

	ADOPTED BUDGET FY 2018-2019	PRORATED BUDGET THRU 7/31/2019	ACTUAL 10 MONTHS ENDING 7/31/2019	VARIANCE FAVORABLE (UNFAVORABLE)
EXPENSES				
ADMINISTRATIVE				
Salaries and Wages	\$ 1,002,793	\$ 848,517	\$ 778,746	\$ 69,771
Special Pay (*)	2,252	2,198	2,198	-
FICA Taxes	76,713	64,911	58,344	6,567
Pension Expense	120,335	101,822	91,924	9,898
Health Insurance	199,390	166,158	141,958	24,200
Workers Comp. Insurance	2,707	2,256	1,772	484
Unemployment Compensation	4,000	3,333	-	3,333
Engineering Fees (*)	33,600	22,400	6,113	16,287
Trustee/Other Debt Expenses (*)	10,740	9,159	9,159	-
Legal Fees	36,000	24,000	15,600	8,400
Special Consulting Services	90,570	75,475	63,502	11,973
Travel & Per Diem (Board)	4,500	3,750	2,792	958
Annual Audit (*)	12,000	12,000	12,000	-
Actuarial Computation - OPEB	2,700	2,250	-	2,250
Management Fees	85,973	71,644	72,040	(396)
Telephone Expense	12,810	10,675	10,640	35
Postage	36,200	30,167	25,745	4,422
Printing & Binding	21,970	18,308	14,524	3,784
Electric Expense	12,000	10,000	7,735	2,265
Rentals and Leases	3,075	2,562	2,077	485
Insurance	15,288	12,740	7,956	4,784
Repair and Maintenance	16,970	14,142	20,186	(6,044)
Legal Advertising	13,800	11,500	445	11,055
Other Current Charges	27,060	22,550	19,992	2,558
Merchant Fees	68,700	57,250	58,142	(892)
Computer/Technology Expenses	63,831	53,193	32,750	20,443
Employment Ads	18,840	15,700	8,118	7,582
Toilet Rebate	14,850	12,375	8,217	4,158
Office Supplies	4,000	3,333	67	3,266
Dues, Licenses, Schools & Permits (*)	12,000	10,000	2,013	7,987
Promotional Expenses (*)	18,310	15,258	15,914	(656)
Capital Outlay (*)	50,000	41,667	9,303	32,364
Total Administrative	\$ 2,093,977	\$ 1,751,293	\$ 1,499,972	\$ 251,321

**CORAL SPRINGS IMPROVEMENT DISTRICT
WATER & SEWER FUND
Statement of Revenues, Expenses and Change in Net Assets
For the Period Ending July 31, 2019**

	ADOPTED BUDGET FY 2018-2019	PRORATED BUDGET THRU 7/31/2019	ACTUAL 10 MONTHS ENDING 7/31/2019	VARIANCE FAVORABLE (UNFAVORABLE)
PLANT OPERATIONS				
Salaries and Wages	\$ 1,715,618	\$ 1,451,677	\$ 1,190,793	\$ 260,884
Special Pay (*)	2,702	2,599	2,599	-
FICA Taxes	131,244	111,053	91,369	19,684
Pension Expense	203,124	171,874	130,046	41,828
Health Insurance	334,514	278,762	216,739	62,023
Workers Comp. Insurance	59,877	49,898	51,297	(1,399)
Water Quality Testing	72,066	60,055	42,430	17,625
Telephone Expense	9,864	8,220	5,017	3,203
Electric Expense	678,409	508,806	459,007	49,799
Rentals and Leases	13,900	11,583	2,609	8,974
Insurance	158,849	132,375	99,527	32,848
Repair & Maintenance-General	694,656	463,104	390,811	72,293
Repair & Maint-Filters for Water Plant (*)	705,050	603,289	603,289	-
Sludge Management - Sewer	150,000	125,000	73,578	51,422
Office Supplies	2,765	2,304	2,075	229
Operating Supplies - General	95,675	79,729	26,283	53,446
Operating Supplies - Chemicals	408,767	306,575	184,856	121,719
Uniforms	9,255	7,713	6,186	1,527
Motor Fuels	81,756	68,130	12,902	55,228
Dues, Licenses, Schools & Permits (*)	71,212	59,343	46,908	12,435
Capital Outlay (*)	3,276,430	2,730,358	2,252,907	477,451
Renewal & Replacement (*)	365,000	304,167	252,767	51,400
TOTAL PLANT OPERATIONS	\$ 9,240,733	\$ 7,536,614	\$ 6,143,995	\$ 1,392,619

**CORAL SPRINGS IMPROVEMENT DISTRICT
WATER & SEWER FUND
Statement of Revenues, Expenses and Change in Net Assets
For the Period Ending July 31, 2019**

	ADOPTED BUDGET FY 2018-2019	PRORATED BUDGET THRU 7/31/2019	ACTUAL 10 MONTHS ENDING 7/31/2019	VARIANCE FAVORABLE (UNFAVORABLE)
FIELD OPERATIONS				
Salaries and Wages	\$ 748,175	\$ 633,071	\$ 533,629	\$ 99,442
Special Pay	1,459	1,245	1,245	-
FICA Taxes	57,235	48,430	40,917	7,513
Pension Expense	89,780	75,968	61,127	14,841
Health Insurance	206,450	172,042	147,532	24,510
Workers Comp. Insurance	34,864	29,053	35,205	(6,152)
Water Quality Testing	1,000	833	-	833
Naturescape Irrigation Service (*)	4,679	4,679	4,819	(140)
Telephone Expense	10,800	9,000	9,630	(630)
Electric Expense	114,735	86,051	66,186	19,865
Rent Expense	17,480	14,567	1,526	13,041
Rent Expense - SCADA	56,040	46,700	46,700	-
Insurance	22,206	18,505	13,046	5,459
Repairs and Maintenance	97,468	81,223	31,866	49,357
R&M Vehicles	20,000	16,667	20,001	(3,334)
R&M Generators	26,083	21,736	13,708	8,028
R&M Lift Stations	168,850	140,708	107,546	33,162
Meters	49,340	41,117	21,872	19,245
Office Supplies	1,680	1,400	628	772
Operating Supplies - General	61,295	51,079	53,203	(2,124)
Uniforms	5,820	4,850	3,592	1,258
Motor Fuels	28,580	23,817	15,007	8,810
Dues, Licenses, Schools & Permits (*)	13,296	11,080	7,149	3,931
Capital Outlay (*)	1,324,000	1,103,333	941,221	162,112
Renewal & Replacement (*)	-	-	-	-
TOTAL FIELD OPERATIONS	\$ 3,161,315	\$ 2,637,154	\$ 2,177,355	\$ 459,799
TOTAL OPERATING EXPENSES	\$ 14,496,024	\$ 11,925,061	\$ 9,821,322	\$ 2,103,739

**CORAL SPRINGS IMPROVEMENT DISTRICT
WATER & SEWER FUND
Statement of Revenues, Expenses and Change in Net Assets
For the Period Ending July 31, 2019**

	ADOPTED BUDGET FY 2018-2019	PRORATED BUDGET THRU 7/31/2019	ACTUAL 10 MONTHS ENDING 7/31/2019	VARIANCE FAVORABLE (UNFAVORABLE)
RESERVES				
Required Reserve for R & R	-	-	-	-
TOTAL OPERATING EXP & RESERVE	\$ 14,496,024	\$ 11,925,061	\$ 9,821,322	\$ 2,103,739
AVAILABLE FOR DEBT SERVICE	\$ 3,103,546		\$ 2,701,188	
DEBT SERVICE				
Principal				
2016 Series	1,595,000	1,329,166	1,329,166	-
Interest				
2016 Series	1,226,405	1,022,005	1,022,005	-
Total Debt Service	\$ 2,821,405	\$ 2,351,171	\$ 2,351,171	\$ -
Excess Revenues (Expenses)	282,141		350,017	
TOTAL DEBT SERV & RESERVES	3,103,546		2,701,188	
Net Assets Beginning			\$ 41,376,817	
Net Assets Ending			\$ 41,726,834	

(*) Not prorated figures

**SUMMARY OF OPERATIONS
& DEBT SERVICE COVERAGE**

	AMOUNT
REVENUES	\$ 12,522,510
OPERATING EXPENDITURES	
Operating Expenditures-Admin	1,499,972
Operating Expenditures-Plant	6,143,995
Operating Expenditures-Field	2,177,355
TOTAL OPERATING EXPENDITURES	\$ 9,821,322
Reserve Required for Future Debt Service	-
TOTAL OPERATING EXPENDITURES & RESERVES	\$ 9,821,322
 AVAILABLE FOR DEBT SERVICE	 \$ 2,701,188
LESS: DEBT SERVICE	2,351,171
EXCESS REVENUES (EXP)	\$ 350,017
	Debt Service Coverage
	1.15

CSID Assessment Collected FY 2018 - 2019

% COLLECTED
REMAINING

BUDGET	% COLLECTED	REMAINING
100%	88%	12%
\$3,849,956	\$3,386,483	\$463,473

DATE	ASSESSMENTS COLLECTED (Net of all Commissions & Fees)
10/31/2018	\$ 0
11/30/2018	497,219
12/31/2018	2,544,812
1/31/2019	68,351
2/28/2019	70,415
3/31/2019	43,334
4/30/2019	88,743
5/31/2019	26,214
6/30/2019	12,310
7/31/2019	35,085
TOTALS	\$3,386,483

CHECK REGISTER – GENERAL FUND

CORAL SPRINGS IMPROVEMENT DISTRICT

CHECK REGISTERS

JULY 2019

FUND	CHECK DATE	CHECK No.	AMOUNT
General Fund	07/01/2019 thru 07/31/2019	#4975 - #5000	\$108,504.04
Total			\$108,504.04

CHECK DATE	VEND#	INVOICE DATE	S...EXPENSED TO... NUMBER YRMO FND DPT ACCT# SUB	VENDOR NAME	STATUS	AMOUNT	CHECK AMOUNT	CHECK #
7/03/19	00023		12000 SW 1ST ST PS 2 121 NW 93RD TER PS 1	FLORIDA POWER & LIGHT CO.			59.61	004975
7/03/19	00267		CANAL PROJECTS	GLOBALTECH, INC.			700.00	004976
7/03/19	00267		WA 153 HURRICANE ASSESS	GLOBALTECH, INC.			1,864.00	004977
7/03/19	01159		MANAGEMENT FEES 06/2019	INFRAMARK, LLC			4,776.00	004978
7/03/19	00248		LEGISLATION 05/2019	LEWIS, LONGMAN & WALKER, P.A.			2,643.18	004979
7/05/19	01171		SOFTWARE 7/1/17-6/30/22	UPLAND SOFTWARE, INC.			8,070.70	004980
7/11/19	01164		MONITOR GF 07/1-09/30/19	CYPRESS TRACE SECURITY INC.			81.00	004981
7/11/19	00284		SUNSHINE 50% PINETREE 25% CSID-GF 25%	WASTE PR@-POMPANO			686.30	004982
7/11/19	01165		COPIER LEASE #7232 07/19 COPIER READS #7232 07/19	XEROX			15.72	004983
7/17/19	01151		PARK PROPERTY 06/2019	BECKER & POLIAK@FF, P.A.			20,693.60	004984
7/17/19	00257		LOGAR VILLAGE 05/2019	GLEN HANKS CONSULTING ENGINEERS			2,450.00	004985
7/17/19	00257		CITY LIAISON 05/2019	GLEN HANKS CONSULTING ENGINEERS			175.00	004986
7/17/19	00257		MISC. SERVICES 05/2019	GLEN HANKS CONSULTING ENGINEERS			437.50	004987
7/17/19	00257		RECERTIFICATIONS 05/2019	GLEN HANKS CONSULTING ENGINEERS			131.25	004988
7/17/19	00172		EXHAUST FANS-CHEM BLDG	GRAINGER, INC.			2,213.24	004989
7/17/19	00248		LEGAL SERVICES 06/2019	LEWIS, LONGMAN & WALKER, P.A.			6,949.40	004990
7/17/19	00248		LEGISLATION 06/2019	LEWIS, LONGMAN & WALKER, P.A.			2,510.40	004991
7/17/19	00292		REIMB BOOT ALLOW FY2019	LUCIBELLO, JUSTIN			80.12	004992
7/26/19	00280		UNITED STATES FLAG FLORIDA STATE FLAG	AMERICAN MADE FLAGS, INC.			238.00	004993
7/26/19	99999		VOID CHECK	*****INVALID VENDOR NUMBER*****			.00	004994
7/26/19	00051		UNIFORM RENTAL 06/19 GASOLINE-GAS 06/19 SPRINT 06/19 SAM'S CLUB-FIELD SUP AMEX-PRYORS SEMINARS-EE 3 AMEX-LAMARCHE-BATTERY CHG TELEPHONE 07/19 POSTAGE 07/19					

CSID -----CSID----- MARTHAR

CHECK DATE	VEND#	INVOICE DATE	NUMBER	S...YRMO	EXPENSED TO... FND DPT ACCT# SUB	VENDOR NAME	STATUS	AMOUNT	CHECK AMOUNT	CHECK #
						PRINT & BINDING 07/19				
						RENT 07/19				
						TECHNOLOGY SHARING 07/19				
						OFFICE SUPPLIES 07/19				
						HEALTH INS...ADMIN 07/19				
7/26/19	00080					HEALTH INS...FIELD 07/19	CORAL SPRINGS IMPROVEMENT DIST WS	19,414.07	004995	
7/26/19	00060					AMT DUE WS 07/24/2019	CORAL SPRINGS IMPROVEMENT DIST WS	28,441.56	004996	
7/26/19	01159					REIMB BOOT ALLOW FY2019	GALOTTI, JASON	90.00	004997	
7/26/19	00157					MANAGEMENT FEES 07/2019	INFRAMARK, LLC	4,776.00	004998	
7/31/19	00237					PARTS	PEP BOYS	21.14	004999	
						2-4D AMINE				
						GLYPHOSATE				
						ALLIGARE	ALLIGARE, LLC	986.25	005000	
						TOTAL FOR BANK G		108,504.04		
						TOTAL FOR REGISTER		108,504.04		

CSID -----CSID---- MARTAR

CHECK REGISTER – WATER & SEWER

CORAL SPRINGS IMPROVEMENT DISTRICT
 CHECK REGISTERS
 JULY 2019

FUND	CHECK DATE	CHECK No.	AMOUNT
Water and Sewer	07/01/2019 thru 07/31/2019	#27603 - #27808	\$1,237,424.46
Total			\$1,237,424.46

CHECK REGISTER – WATER & SEWER

CSID - WATER & SEWER FUND
 BANK H CHKING-ENTERPRISE

CHECK DATE	VEND#	INVOICE DATE	S... NUMBER	EXPENSED TO... YRMO FND DPT ACCT# SUB	VENDOR NAME	STATUS	AMOUNT	CHECK... AMOUNT	...
7/02/19	00822				AFLAC-W/H 06/19 AFLAC-PTREE 06/19			2,746.20	027603
7/02/19	00005				COT-SOD HYPO 58% COT-SOD HYPO 42%	ALLIED UNIVERSAL CORP.		2,436.22	027604
7/02/19	01227				CAMERAS-REPAIRS	AMC SURVEILLANCE CAMERAS		369.00	027605
7/02/19	01354				GAP INS-PTREE 06/13/2019 GAP INS-W/H 06/13/2019 GAP INS-PTREE 06/27/2019 GAP INS-W/H 06/27/2019 GAP INS-BOARD 06/30/2019	AMERICAN PUBLIC LIFE INSURANCE		807.40	027606
7/02/19	00694				TECH SUPP 05/26-06/25/19	ASSOCIATED SYSTEMS, INC.		1,185.00	027607
7/02/19	01403				UNIT=042 REPAIRS UNIT=014 REPAIRS UNIT=042 REPAIRS	AUTO NATION FORD MARGATE		3,133.40	027608
7/02/19	00889				BOLTS/NUTS	BROWARD BOLT		203.70	027609
7/02/19	00352				UTILITY TAXES 06/2019	CITY OF CORAL SPRINGS		54,443.09	027610
7/02/19	01452				WELL 3-NEW METER INSTALL INSTALL TRANSDUCER-GAUGE BLOWER 2-CONTROLS PLANT F-REPAIRS	DELTA CONTROLS		2,605.00	027611
7/02/19	00018				METER BOXES PUMP KIT-PUMP 403 PARTS-CREDIT	FEL-POMPANO BEACH,FL WWS# 125		2,265.66	027612
7/02/19	01540				GIS SERVICES	FLORIDA TECHNICAL CONSULTANTS, LLC		2,040.00	027613
7/02/19	01651				SCADA SUPPORT RENEW SCADA SUPPORT RENEW	GE DIGITAL LLC		6,393.14	027614
7/02/19	00063				TOOLS SURGE TANK-BLOWERS	GRAINGER, INC.		1,187.84	027615
7/02/19	00179				PH PROBES & CABLE FREIGHT	HACH COMPANY		1,067.02	027616
7/02/19	01535				FLUORIDE	HAWKINS, INC.		990.00	027617
7/02/19	01507				USED OIL DISPOSAL	HERITAGE-CRYSTAL CLEAN LLC		55.00	027618
7/02/19	00346				HYDRANT-HOSES	INDUSTRIAL HOSE & HYDRAULICS, INC.		330.00	027619
7/02/19	01486				DIESEL FUEL DIESEL	LANK OIL COMPANY		4,342.61	027620
7/02/19	01341				LS 2-PROJECT 1				

CSID *****CSID***** MARTHAR

CHECK DATE	VEND#	INVOICE DATE	S... NUMBER	EXPENSED TO... YRMO FND DPT ACCT# SUB	VENDOR NAME	STATUS	AMOUNT	CHECK... AMOUNT	... #
7/02/19	01061			LS 2-PROJECT 1	LMK PIPE RENEWAL LLC		42,616.00	027621	
7/02/19	00683			MEALS-FASD MEETING MILEAGE/TOLLS-FASD MTG	MCINTOSH, DAVID		188.76	027622	
7/02/19	00045			GEN 1-ATS TROUBLESHOOTING	OK GENERATORS		717.50	027623	
7/02/19	01410			UNIT=039 RADIATOR CAP TRANSFER PUMP 7-OIL	PEP BOYS		50.80	027624	
7/02/19	01550			METER REPLACEMENTS	RG3 METER COMPANY		3,377.84	027625	
7/02/19	01324			PH PROBES	ROSEMOUNT INC.		710.00	027626	
7/02/19	00053			MEALS-FASD MEETING MILEAGE/TOLLS-FASD MTG ACCOMMODATIONS-FASD	SHANK. DR. MARTIN		1,060.01	027627	
7/02/19	01485			PAINT BELT BLDG	SHERWIN-WILLIAMS		301.10	027628	
7/02/19	01175			HYDROXIDE SKID-REPAIRS	TRINOVA-FLORIDA		3,650.00	027629	
7/02/19	01561			UNIFORMS-WATER UNIFORMS-WW UNIFORMS-MAINT UNIFORMS-FIELD 06/19/19 UNIFORMS-GF 06/19/19 UNIFORMS-WATER UNIFORMS-WW UNIFORMS-MAINT UNIFORMS-FIELD 06/26/2019 UNIFORMS-GF 06/26/19	UNIFIRST CORPORATION		399.82	027630	
7/02/19	01562			PRINCIPAL 2016 SER 07/19	US BANK		136,666.67	027631	
7/02/19	00441			INTEREST 2016 SER 07/19	US BANK		98,146.46	027632	
7/02/19	01472			LAB EQUIPMENT LAB EQUIPMENT FREIGHT LAB CHEMICALS/SUPPLIES FRIEGHT LAB CHEMICAL	USA BLUEBOOK		1,242.22	027633	
7/02/19	01264			DUCAL 4 MESH-DRUM FREIGHT	W.A. HAMMOND DRIERITE CO., LTD.		450.50	027634	
7/02/19	@1264			ADMIN PHONE 07/19 WASTE PHONE 07/19 FIELD PHONE 07/19	WINDSTREAM COMMUNICATIONS, LLC		240.71	027635	
7/02/19	@1318			ADMIN PHONE 07/19 FIELD PHONE 07/19	WINDSTREAM COMMUNICATIONS, LLC		181.27	027636	
7/02/19				PUMP PARTS-2 REPAIR KITS	XYLEM WATER SOLUTIONS USA, INC.		5,826.00	027637	

CSID -----CSID----- MARTHAR

CHECK DATE	VEND#	INVOICE DATE	NUMBER	EXPENSED TO YRMO	FND DPT ACCT# SUB	VENDOR NAME	STATUS	AMOUNT	CHECK AMOUNT	CHECK #
7/08/19	99999					VOID CHECK	*****INVALID VENDOR NUMBER*****		.00	027638
7/08/19	99999					VOID CHECK	*****INVALID VENDOR NUMBER*****		.00	027639
7/08/19	99999					VOID CHECK	*****INVALID VENDOR NUMBER*****		.00	027640
7/08/19	99999					VOID CHECK	*****INVALID VENDOR NUMBER*****		.00	027641
7/08/19	99999					VOID CHECK	*****INVALID VENDOR NUMBER*****		.00	027642
7/08/19	01130					GST 4MG 9050411 LAMARCHE..BATTERY CHARGER CBOD & TSS 9050054 SOUR #7 9050076 CBOD & TSS 9050077 CBOD & TSS 9050078 CBOD & TSS 9050108 CBOD & TSS 9050237 MONTHLYS BACTIS 9050238 AMMONIA TEST 9050239 MONTHLY BACTIS 9050496 GST 4MG 9050295 CBOD & TSS 9050327 TOTAL P & N 9050328 CBOD & TSS 9050329 RO CONCEN 9050330 MONTIORING WELLS 9050331 FLUORIDE 9050333 WELL 5 9050334 CBOD & TSS 9050352 CBOD & TSS 9050353 CBOD & TSS 9050407 CBOD & TSS 9050417 MONTHLY BACTIS 9050418 CBOD & TSS 9050431 WTP QUARTERLY MONT 905043 BACTERIA TEST 9050443 MWC-01 SAMPLING 9050475 PLATE COUNT 9050491 WTP QUARTERLY MONT 905049 CBOD & TSS 9050493 CBOD & TSS 9050494 CBOD & TSS 9050495 CBOD & TSS 9050943 CBOD & TSS 9050642 CBOD & TSS 9050643 CBOD & TSS 9050644 CBOD & TSS 9050728 CBOD & TSS 9050730 PHASE 2 9050732 DISINFECT TEST 9050734 PHASE 2 9050750 DISPUTE CHARGE-CREDIT				

CSID - - - - CSID - - - - MARTHAR

CHECK DATE	VEND#	INVOICE DATE	NUMBER	S...EXPENSED TO... YRMO FND DPT ACCT# SUB	VENDOR NAME	STATUS	AMOUNT	...CHECK... AMOUNT	...	#
					CBOD & TSS 9050907					
					CBOD & TSS 9050908					
					CBOD & TSS 9050944					
					CBOD & TSS 9050946					
					WYNDHAM-SEDA SYMPOSIUM					
					NORTON ANTI-VIRUS-5 SEATS					
					ANTHONYS-MANAGER MEETING					
					AMAZON-RADIO BATTERIES-QT					
					AMAZON-RADIO BATTERIES-QT					
					AMAZON-RADIO BATTERIES-QT					
					AMAZON-RADIO BATTERIES-QT					
					ANTHONY-DEPT LUNCH					
					MISSION BBQ-FASD LUNCH-1					
					MARRIOTT-FASD DAVID M.					
					MARRIOTT-FASD LUNCH- 1					
					AMAZON-TONER 280X					
					AMAZON-TONER M477FNW					
					E-TRAILER HITCH					
					HYDRANA..7 NEW MEMBRANE					
					FREIGHT					
					ANTHONYS-MONTHLY LUNCH					
					ANTHONYS-MONTHLY LUNCH					
					PRYOR-RENEWAL QTY 2					
					PRYOR-RENEWAL QTY 3					
					PRYOR-RENEWAL QTY 3					
					PRYOR-RENEWAL					
					PRYOR-RENEWAL QTY 1					
					PRYOR-RENEWAL QTY 3					
					INDEED-EMPLOY-FIELD					
					FLOOR&DECOR-BATHROOMS-2					
					EVERFI-HR SOFTWARE					
					WAYFAIR-MEN'S VANITY					
					FRANCOTYP-POSTAGE-REFILL					
					FLEETIQ-MONTHLY FEE	AMERICAN EXPRESS		23,340.575	027643	
7/08/19	88888				400045808 SANDOLLAR INVES	SANDOLLAR INVESTMENT GROUP		99.68	027644	
7/08/19	88888				710029308 PHUNG THU	THU PHUNG		214.82	027645	
7/08/19	88888				@10413705 *SAEZ /PERGER	*BRANDI SAEZ/MARIO PERGER		46.39	027646	
7/08/19	88888				720002607 FERRETTI/BUSTIL	JEFF FERRETTI/A BUSTILLO		146.60	027647	
7/08/19	88888				020411908 F2R ASSETS LLC	F2R ASSETS LLC		100.00	027648	
7/08/19	88888				520941515 *MARK TALEY	*TALEY MARK		61.93	027649	
7/08/19	88888				930589106 BENTLEY DAVID/C	DAVID/CAROL BENTLEY		7.25	027650	
7/08/19	88888				840100005 BROCK MEG	MEG BROCK		412.86	027651	
7/08/19	88888				240304405 MINICHELLO RIC	RICHARD MINICHELLO JR		9.77	027652	
7/08/19	88888				140715409 *IMBRES JOHN	*JOHN IMBRES		142.55	027653	

CSID -----CSID----- MARTHAR

CHECK DATE	VEND#	INVOICE DATE	NUMBER	EXPENSED TO YRMO	TO S FND DPT ACCT# SUB	VENDOR NAME	STATUS	AMOUNT	CHECK AMOUNT	CHECK #
7/08/19	88888		940827904		CRANE AMENICIA	AMENICIA DOLEEN CRANE			61.93	027654
7/08/19	88888		850137609		HOWARD SHANNON/	SHANNON HOWARD/MELISSA SHEV			100.00	027655
7/08/19	88888		450143221		NOFIL JOSEPH	JOSEPH NOFIL			211.93	027656
7/08/19	88888		850160425		*SUAREZ JEYSSA	*JEYSSA SUAREZ			28.12	027657
7/08/19	88888		650437205		LEON LUIS/MELBA	LUIS/MELBA LEON			170.69	027658
7/08/19	88888		350500106		*BROECKELMANN L	*LAUREN BROECKELMANN			100.00	027659
7/08/19	88888		150791804		LOMBARD MITCHEL	MITCHELL LOMBARD			81.04	027660
7/08/19	88888		760034402		MADGAR DONNA	DONNA MADGAR			100.00	027661
7/08/19	88888		760076908		YAU SHING WAI	WAI SHING YAU			26.97	027662
7/08/19	88888		060630210		BLEICH SCOTT	SCOTT BLEICH			42.13	027663
7/08/19	88888		460931101		RAMBLEWOOD SQ	RAMBLEWOOD SQ LLC			10,000.00	027664
7/08/19	88888		270351505		BROOKS ERICA	ERICA BROOKS			142.51	027665
7/08/19	88888		470608219		HECTOR ETUDE	ETUDE HECTOR			42.21	027666
7/08/19	88888		470696004		ZAKARIN RON	RON ZAKARIN			15.48	027667
7/08/19	88888		080715814		IH3 PROPERTY FL	IH3 PROPERTY FL LP			176.14	027668
7/08/19	88888		080718409		*CRISCI LOUIS/C	*LOUIS/CHRISTINE CRISCI			27.08	027669
7/08/19	88888		080798706		MC CARTHY DOROT	DOROTHY MC CARTHY			61.93	027670
7/08/19	88888		888009501		AQUA FORCE PRES	AQUA FORCE PRESSURE CLEANING			394.85	027671
7/08/19	88888		790789809		ANTOINE PHILPPE	PHILPPE ANTOINE			61.40	027672
7/08/19	88888		890906803		MICHAELS K. REE	KATHLEEN MICHAELS-REES			125.00	027673
7/09/19	01653				MEN'S BATHROOM	H2O CLEAN LLC			3,850.00	027674
7/09/19	99999				VOID CHECK	*****INVALID VENDOR NUMBER*****			.00	027675
7/09/19	00425				ADMIN-COFFEE SUPP 06/19					
					ADMIN-BOARD MTG					
					WATER-COFFEE/GATORADE					
					WATER-CLEANING SUPP					
					WW-COFFEE/GATORADE					
					WW-CLEANING SUPP					
					MAINT-COFFEE/GATORADE					
					MAINT-CLEANING SUPP					
					FIELD-COFFEE/GATORADE					

CSID -----CSID----- MARTHAR

CHECK DATE	VEND#	INVOICE DATE	NUMBER	EXPENSED TO... YRMO FND DPT ACCT# SUB	VENDOR NAME	STATUS	AMOUNT	CHECK AMOUNT	CHECK #
7/11/19	00005			FIELD-CLEANING SUPP FIELD-GF-CLEANING SUPP FIELD-GF-COFFEE/GATORADE FIELD-PT-COFFEE SUPP FIELD-PT-CLEANING SUPP FIELD-SS-COFFEE SUPP FIELD-SS-CLEANING SUPP	SAM'S CLUB/SYNCHRONY BANK		535.03	027676	
7/11/19	01227			COT SOD HYPO 58¢ COT SOD HYPO 42¢	ALLIED UNIVERSAL CORP.		2,430.24	027677	
7/11/19	00857			NANO CAMERA-VIDEO RECEIVE	AMC SURVEILLANCE CAMERAS		588.00	027678	
7/11/19	01503			SARATOGA .HYDRANT PARTS VENCO-UNIT=047 CRANE PART	CAPITAL ONE		3,401.19	027679	
7/11/19	01256			FEED MOTOR 1-INSTALL	CONDO ELECTRIC MOTOR REPAIR CORP.		1,800.00	027680	
7/11/19	00174			SOD	CORAL SPRINGS NURSERY, INC.		195.00	027681	
7/11/19	01327			MONITOR ADM 07/1-09/30/19	CYPRESS TRACE SECURITY INC.		81.00	027682	
7/11/19	00999			RENTAL-CENTRAL RENTAL-LS	DATA FLOW SYSTEMS, INC		4,670.00	027683	
7/11/19	00017			PRE-EMPL.CK - PINETREE PRE-EMPL.CK - WATER	FEDERAL BACKGROUND SERVICES, INC		130.00	027684	
7/11/19	00018			OVERNIGHT SERVICE	FEDEX		37.22	027685	
7/11/19	00023			RESTOCK PARTS-FIELD	FEL-POMPANO BEACH, FL WW # 125		834.00	027686	
7/11/19	00031			ADMIN ELECTRIC 06/19 PLT-WATER ELECTRIC 06/19 PLT-WASTE ELECTRIC 06/19 FIELD ELECTRIC 06/19	FLORIDA POWER & LIGHT CO.		56,120.69	027687	
7/11/19	01515			10HP PUMP CABLE	GRAYBAR ELECTRIC CO.		294.28	027688	
7/11/19	01535			ASPHALT	HARDRIVES ASPHALT COMPANY		139.83	027689	
7/11/19	01329			SULFURIC ACID AMMONIUM SULFATE SODIUM HYDROXIDE	HAWKINS, INC.		5,477.62	027690	
7/11/19	01459			IRA-07/09/19 PLAN 705880	VANTAGEPOINT TRANSFER AGENTS-705880		765.00	027691	
7/11/19	00044			DRUG SCREEN-NEW EE/PT DRUG SCREEN-NEW EE/WATER POST ACCIDENT-MAINTENANCE	MEDEXPRESS URGENT CARE OF BOYNTON		168.00	027692	
				ADPT, GIG, ETHRN DVD-25 PACK DVD-25 PACK	OFFICE DEPOT BUSINESS CREDIT		41.24	027693	

CSID -----CSID---- MARTHAR

CHECK DATE	VEND#	INVOICE DATE	S...EXPENSED TO... NUMBER YRMO FND DPT ACCT# SUB	VENDOR NAME	STATUS	AMOUNT	CHECK AMOUNT	CHECK #
7/11/19	01150			OFFICE SUPPLIES-MISC OFFICE SUPPLIES-MISC 2 BINDERS 2 USB FLASH DRIVES-MARTA	OFFICE DEPOT		100.12	027694
7/11/19	01355			DR-JULY 2019-PREPAID SERVICES 06/26-07/25/2019	OFFICESTREAM, INC.		480.00	027695
7/11/19	00683			SVC AGREEMENT GENERATORS SVC AGREEMENT GENERATORS SVC AGREEMENT GENERATORS	OK GENERATORS		1,835.00	027696
7/11/19	01419			REIMB TO \$7,000 06/30/19	POSTMASTER GENERAL		2,477.06	027697
7/11/19	01416			UTIL STMTS 06/2019 ADD'L METERED POSTAGE	PRIDE ENTERPRISES		1,138.79	027698
7/11/19	01654			RESTORE DAMAGE AREAS	DON SCHICK, LLC		500.00	027699
7/11/19	00053			HSP ROOM-PAINT	SHERWIN-WILLIAMS		244.40	027700
7/11/19	01510			UNIT=047 LIGHTBOARD	STROBES-R-US INC		113.10	027701
7/11/19	01290			LS #2-REHAB & REPAIR	TRIO DEVELOPMENT CORPORATION		122,330.68	027702
7/11/19	01290			LS #5-REHAB & REPAIR	TRIO DEVELOPMENT CORPORATION		125,363.68	027703
7/11/19	01175			UNIFORMS-WATER UNIFORMS-WW UNIFORMS-MAINT UNIFORMS-FIELD UNIFORMS-GF 07/03/19	UNIFIRST CORPORATION		205.08	027704
7/11/19	01564			LEVY LOANS PER 07-11-2019	US DEPARTMENT OF EDUCATION AWG		225.54	027705
7/11/19	00441			LAB CHEMICALS FREIGHT	USA BLUEBOOK		606.60	027706
7/11/19	01529			TRASH SERVICES-06/2019	WASTE PRO-POMPANO		484.96	027707
7/11/19	01011			COPIER LEASE #7835PT06/19 COPIER READS #7835PT06/19 COPIER READS #7835P 06/19 COPIER READS #7535P 06/19	XEROX CORPORATION		231.50	027708
7/11/19	01318			NEW PUMPS- QTY 3	XYLEM WATER SOLUTIONS USA, INC.		37,626.65	027709
7/16/19	99999			VOID CHECK	*****INVALID VENDOR NUMBER*****		.00	027710
7/16/19	99999			VOID CHECK	*****INVALID VENDOR NUMBER*****		.00	027711
7/16/19	00033			ROTOGUARD-PARTS TOOLS				

CSID -----CSID----- MARTHAR

CHECK DATE	VEND#	INVOICE DATE	EXPENSED TO YRMO FND DPT ACCT# SUB	VENDOR NAME	STATUS	AMOUNT	CHECK AMOUNT	CHECK #
				TOOLS				
				PARTS				
				CONTACT CHAMBER-SUPPLIES				
				HEADWORKS-SUPPLIES				
				REPLACEMENT TOOLS				
				REPLACEMENT TOOLS				
				RETURN-ADMIN BATHROOM				
				HSP ROOM-LED LIGHTING				
				SPRINKLER SUPPLIES				
				REPLACEMENT TOOLS				
				HSP-LED LIGHTING				
				CONCRETE-VALVE MOUNTING				
				TRASH BAGS-BULBS				
				HSP LIGHTING-SUPPLIES				
				CREDIT-SALES TAX				
				ROPE				
				IMPACT DRILL				
				ADMIN-BATHROOM SUPPLIES				
				IMPACT DRILL				
				IMPACT DRILL-RETURN				
				HAND TRUCK				
				ADMIN-MEN'S BATHROOM				
				BELT PRESS SUPPLIES				
				BELT PRESS-SUPPLIES				
				HSP ROOM SENSOR				
				RETURN-SENSOR				
				BATTERY-ADMIN				
				ROPE				
				RETURN-SALES TAX				
				BULBS				
				RETURN-DAMAGED BULBS				
				BULBS				
				BULBS				
				MISC PARTS				
7/17/19	01085			MISC PARTS	HOME DEPOT		4,665.67	027712
				HEADWORKS-PARTS	A. TARLER, INC.		280.75	027713
7/17/19	00822			AFLAC-W/H 07/19				
				AFLAC-PTREE 07/19	AFLAC		2,746.20	027714
7/17/19	01374			ADMIN VISION 08/19				
				WATER VISION 08/19				
				WW VISION 08/19				
				MAINT VISION 08/19				
				FIELD VISION 08/19				
				VISION..CSID-GF 08/19				
				VISION..PINETREE 08/19	AMERITAS LIFE INSURANCE CORP-VISION		878.40	027715
7/17/19	01502			MAIN GATE-CUT 2 NEW LOOPS	AT & I SYSTEMS		1,100.00	027716
7/17/19	01432			BIO-MAX BLOCKS-HEADWORKS				
				SHIPPING	BACTICORP, LLC		1,228.00	027717
7/17/19	01578			INTERNET CONNECTION 07/19	BLUE STREAM		156.79	027718

CSID -----CSID----- MARTHAR

CHECK DATE	VEND#	INVOICE DATE	S...EXPENSED TO... NUMBER YRMO FND DPT ACCT# SUB	VENDOR NAME	STATUS	AMOUNT	CHECK AMOUNT
7/17/19	01256			SOD			123.55	027719	
7/17/19	01479			LOCATE SERVICES			1,200.00	027720	
7/17/19	00018			RESTOCK PARTS			48.00	027721	
7/17/19	01610			ENTERPRISE/MISC 05/2019			1,006.25	027722	
7/17/19	01610			ATLANTIC CROSSINGS			700.00	027723	
7/17/19	01408			MEALS-FASD MEETING MILEAGE/TOLLS-FASD MTG ACCOMMODATIONS-FASD			986.58	027724	
7/17/19	01093			MONTHLY MAINT-JULY			3,901.41	027725	
7/17/19	01302			LEGAL SERVICES 06/2019			315.00	027726	
7/17/19	01302			LEGISLATION 06/2019			2,510.40	027727	
7/17/19	00838			BELT PRESS-LIFT STATION			657.01	027728	
7/17/19	01652			CLAIM 0830-149558			500.00	027729	
7/17/19	01150			NEW CHAIR-ANA VIVIEN			154.99	027730	
7/17/19	01563			REIMB BOOT ALLOW 7/15/19			90.00	027731	
7/17/19	01443			POSTAGE METER INK PIC40			260.00	027732	
7/17/19	01410			METER REPLACEMENT SHIPPING			1,553.31	027733	
7/17/19	01571			PEST CONTROL-ADMIN 07/19 PEST CONTROL-MAINT 07/19			250.00	027734	
7/17/19	01632			REIMB BOOT ALLOW 7/15/19			90.00	027735	
7/17/19	00155			ADMIN SPRINT 07/19 PLANT-WATER SPRINT 07/19 PLANT-WASTE SPRINT 07/19 PLANT-MAINT SPRINT 07/19 FIELD SPRINT 07/19 SPRINT 07/19 DUE SUNSHINE SPRINT 07/19 DUE CSID GF			1,218.58	027736	
7/17/19	00200			NOTICE ATTORNEY-CLIENT PERMIT-WASTE FACILITY			797.95	027737	
7/17/19	01175			UNIFORMS-WATER UNIFORMS-WW UNIFORMS-MAINT					

CSID -----CSID----- MARTNAR

CHECK DATE	VEND#	INVOICE DATE	NUMBER	EXPENSED TO... YRMO FND DPT ACCT# SUB	VENDOR NAME	STATUS	AMOUNT	CHECK AMOUNT	CHECK #
7/17/19	00441			UNIFORMS-FIELD UNIFORMS-GF 07/10/19	UNIFIRST CORPORATION		205.08	027738	
7/17/19	01264			BIO-MAX HYDRANT FLUSH FREIGHT	USA BLUEBOOK		365.90	027739	
7/17/19	01264			FRONT GATE PHONE 07/19	WINDSTREAM COMMUNICATIONS, LLC		84.72	027740	
7/17/19	01318			ADMIN PHONE 07/19 FIELD PHONE 07/19	WINDSTREAM COMMUNICATIONS, LLC		737.13	027741	
7/17/19	00127			ALL LIFT STATIONS-PARTS	XYLEM WATER SOLUTIONS USA, INC.		3,228.00	027742	
7/17/19	01332			ADMIN-BATHROOM MEN	ACTION SUPPLY - MARGATE DO NOT USE		62.44	027743	
7/17/19	01373			MEMBRANE DYE TEST CL2-BROMINE TESTING	(AWC)AMERICAN WATER CHEMICALS, INC.		5,650.00	027744	
7/17/19	01089			ADMIN DENTAL 08/19 WATER DENTAL 08/19 WW DENTAL 08/19 MAINT DENTAL 08/19 FIELD DENTAL 08/19 DENTAL..CSID-GF 08/19 DENTAL..PINETREE 08/19	AMERITAS LIFE INSURANCE CORP-DENTAL		4,532.16	027745	
7/17/19	00889			PLANT PHONE WATER 07/2019	AT & T		69.48	027746	
7/17/19	01452			CEMENT DRILL BITS	BROWARD BOLT		29.64	027747	
7/17/19	00018			AMMONIA TANK-NEW ISOLATOR WELL 6-TROUBLESHOOT HSP-BACK UP POWER SUPPLY TROUBLESHOOT-SWITCHES BLOWER-SERVICE CALL	DELTA CONTROLS		3,665.00	027748	
7/17/19	01535			RESTOCK PARTS RESTOCK PARTS	FEL-POMPANO BEACH,FL WW # 125		338.68	027749	
7/17/19	01093			PLUS ANTISCALANT CORROSION INHIBITOR FLUORIDE AMMONIA	HAWKINS, INC.		7,509.20	027750	
7/17/19	01486			FERTILIZE FICUS	JLS LANDSCAPE SERVICES, INC.		275.00	027751	
7/17/19	01051			UNLEADED GAS	LANK OIL COMPANY		3,746.04	027752	
7/17/19	01500			EMERG LIGHT-BATTERY	LIGHT BULBS UNLIMITED		95.92	027753	
7/17/19	01231			CLAIM 0830-149558	MARTIN, TIM		100.00	027754	
				ADMIN LIFE INS 08/19 WATER LIFE INS 08/19					

CSID -----CSID----- MARTHAR

*** CHECK NOS. 027603-027808

CSID -SWATER & SEWER FUND
BANK H CHKING-ENTERPRISE

CHECK DATE	VEND#	INVOICE DATE	S.S. NUMBER	EXPENSED TO... YRMO FND DPT ACCT# SUB	VENDOR NAME	STATUS	AMOUNT	CHECK AMOUNT	S.S.#
7/17/19	01406			WW LIFE INS 08/19 MAINT LIFE INS 08/19 FIELD LIFE INS 08/19 LIFE INS W/H..WS 08/19 LIFE INS W/H..GF 08/19 LIFE INS.CSID-GF.ER 08/19 LIFE INS.PINETREE-ER08/19 LIFE INS.PINETREE-EE08/19	MUTUAL OF OMAHA		5,224.25	027755	
7/17/19	00045			DFS-SHIPPED TCU-DFS BAD RADIO BOARD-DFS BREAKER-BLOWER RM RADIO CARD-DFS CREDIT-OVERCHARGED	PAKMAIL		119.26	027756	
7/17/19	00351			TRAILER WIRES	PEP BOYS		35.54	027757	
7/17/19	00829			SAFETY LEATHER GLOVES	RITZ SAFETY EQUIPMENT, LLC		107.04	027758	
7/17/19	00782			ALL LS PANELS-DANGER SIGN FREIGHT	SETON IDENTIFICATION PRODUCTS		381.79	027759	
7/17/19	01175			LOCATE TICKETS-6/19	SUNSHINE STATE ONE CALL OF FLA.		234.16	027760	
7/17/19	00441			UNIFORMS-WATER UNIFORMS-WW UNIFORMS-MAINT UNIFORMS-FIELD UNIFORMS-GF 07/17/19	UNIFIRST CORPORATION		205.08	027761	
7/29/19	01194			LAB CHEMICALS FREIGHT	USA BLUEBOOK		139.70	027762	
7/29/19	01630			AC=008 NEW UNIT	AIR AMERICA AIR CONDITIONING, LLC		5,469.29	027763	
7/29/19	01227			OXYGEN-SMALL/MED PORTABLE ACETYLENE-SM/LG PORTABLE HAZMAT CHARGE	AIRGAS USA, LLC		161.45	027764	
7/29/19	01354			PREVENTATIVE MAINT-CAMERA	AMC SURVEILLANCE CAMERAS		455.00	027765	
7/29/19	01452			GAP INS-PTREE 07/11/2019 GAP INS-W/H 07/11/2019 GAP INS-PTREE 07/25/2019 GAP INS-W/H 07/25/2019 GAP INS-BOARD 07/31/2019	AMERICAN PUBLIC LIFE INSURANCE		773.48	027766	
7/29/19	01353			CALIBRATION TRAINS	DELTA CONTROLS		780.00	027767	
7/29/19	00017			REIMB BOOT ALLOW FY2019	DUNBAR, ROGER		90.00	027768	
7/29/19	00018			OVERNIGHT SERVICE	FEDEX		72.74	027769	
				METER BOXES					

CSID -----CSID----- MARTHAR

CHECK DATE	VEND#	INVOICE DATE	NUMBER	EXPENSED TO... YRMO FND DPT ACCT# SUB	VENDOR NAME	STATUS	AMOUNT	CHECK AMOUNT	CHECK #
7/29/19	01360			RESTOCK PARTS	FEL-POMPANO BEACH, FL WW # 125		3,924.80	027770	
7/29/19	01360			WA 140 DUAL ZONE WELL 4	GLOBALTECH, INC.		15,641.18	027771	
7/29/19	01360			WA 133 ARC FLASH STUDY	GLOBALTECH, INC.		19,631.25	027772	
7/29/19	01360			WA 137CSID IMPROVE HSP1&2	GLOBALTECH, INC.		498.74	027773	
7/29/19	01360			WA 141 WWTP PLANT D	GLOBALTECH, INC.		202,960.37	027774	
7/29/19	01360			WA 152 MEMBRANE ANALZYER	GLOBALTECH, INC.		10,579.68	027775	
7/29/19	01360			WA 156 WELL 8 RE-DEVELOP	GLOBALTECH, INC.		22,949.83	027776	
7/29/19	01360			WA 158 2019 GST REPAIRS	GLOBALTECH, INC.		2,399.18	027777	
7/29/19	01360			WA 160 WELL 3 PUMP REPLAC	GLOBALTECH, INC.		540.00	027778	
7/29/19	01360			WA 161 FEED MOTOR REPAIR	GLOBALTECH, INC.		15,365.50	027779	
7/29/19	01329			IRA-07/23/19 PLAN 705880	VANTAGEPOINT TRANSFER AGENTS-705880		765.00	027780	
7/29/19	01605			MANAGEMENT FEE 07/19 COPIES 07/19	INFRAMARK,LLC		7,992.20	027781	
7/29/19	01579			REIMB BOOT ALLOW FY2019	JIMENEZ, JUAN		90.00	027782	
7/29/19	01506			BALL BEARING	KAMAN INDUSTRIAL TECHNOLOGIES CORP.		310.25	027783	
7/29/19	01655			REIMB BOOT ALLOW FY2019	MAHARAJ, ANAND		90.00	027784	
7/29/19	01645			REIMB BOOT ALLOW FY2019	MATHERSON II, RICHARD		90.00	027785	
7/29/19	01647			REIMB BOOT ALLOW FY2019	MILLER, KENNETH		80.24	027786	
7/29/19	01471			SATELLITE PHONE-TEST	NETWORK INNOVATIONS US, INC.		6.20	027787	
7/29/19	01125			REIMB BOOT ALLOW FY2019	OUIMET, STEPHEN		90.00	027788	
7/29/19	00045			UNIT=118 OIL FILTER-OIL	PEP BOYS		31.08	027789	
7/29/19	01259			RESPIRATORS	POLLARDWATER		244.48	027790	
7/29/19	01166			REIMB BOOT ALLOW FY2019	RODRIGUEZ, DANIEL		90.00	027791	
7/29/19	01650			MEN'S BATHROOM-FIX URINAL	SHAWN & SONS		245.00	027792	
7/29/19	01253			REIMB BOOT ALLOW FY2019	STEPHENS, JOSEPH		90.00	027793	
7/29/19	01175			POLOS-LEN O. 7/17/2019 POLOS-MARTIN S.7/17/2019 POLOS-DUANE H.7/17/2019	UNIFIRST CORPORATION		138.62	027794	
7/29/19	01564			LEVY LOANS PER 07-25-2019	US DEPARTMENT OF EDUCATION AWG		225.54	027795	

CSID -----CSID----- MARTHAR

CHECK DATE	VEND#	INVOICE DATE	S...EXPENSED TO... NUMBER YRMO FND DPT ACCT# SUB	VENDOR NAME	STATUS	AMOUNT	CHECK... AMOUNT #
7/29/19	00441			LAB CHEMICALS	USA BLUEBOOK		58.21 027796
7/29/19	01609			REIMB BOOT ALLOW FY2019	VAZQUEZ, PEDRO		90.00 027797
7/29/19	01318			PART-PUMP CONVERTER PART-PUMP CONVERTER PART-PUMP CONVERTER	XYLEM WATER SOLUTIONS USA, INC.		631.50 027798
7/31/19	01249			REIMB BOOT ALLOW FY2019	ALMEIDA, RICARDO		86.66 027799
7/31/19	01641			OPERATOR "C" LICENSE	BATES, DANIEL		100.00 027800
7/31/19	01240			REIMB BOOT ALLOW FY2019	BROCK, WILLIAM		90.00 027801
7/31/19	01595			TRANSCRIPT/SHADE SESSION	ESQUIRE DEPOSITION SOLUTIONS, LLC		395.00 027802
7/31/19	01423			ADMIN HLTH INS 08/19 WATER HLTH INS 08/19 WW HLTH INS 08/19 MAINT HLTH INS 08/19 FIELD HLTH INS 08/19 ADMIN HLTH INS-GF 08/19 FIELD HTH INS-GF 08/19 DUE FROM SHANK 08/19 DUE FROM PTREE 08/19	FLORIDA BLUE		63,495.75 027803
7/31/19	01629			REIMB BOOT ALLOW FY2019	HOSEIN, FARAZ		39.28 027804
7/31/19	01646			REIMB BOOT ALLOW FY2019	MCSHEA, CHRISTIAN		90.00 027805
7/31/19	01628			UNIT=039 REPAIRS	POPS GARAGE INC.		1,615.02 027806
7/31/19	00425			ADMIN-4TH OF JULY LUNCH ADMIN-DVD ADMIN-INSURANCE MEETING WATER-CLEANING SUPP WW-CLEANING SUPP MAINT-CLEANING SUPP FIELD-CLEANING SUPP FIELD-GP-CLEANING SUPP FIELD-PT-CLEANING SUPP FIELD-SS-CLEANING SUPP	SAM'S CLUB/SYNCHRONY BANK		697.39 027807
7/31/19	01175			UNIFORMS-WATER UNIFORMS-WW UNIFORMS-MAINT UNIFORMS-FIELD UNIFORMS-GF 07/24/19	UNIFIRST CORPORATION		205.05 027808
						TOTAL FOR BANK H	1,237,424.46
						TOTAL FOR REGISTER	1,237,424.46
CSID -----CSID----- MARTHAR							

Sixth Order of Business

6A.

Upon Approval or Request for Revision Please contact Isaac or lbrain at permit@cwsifl.com or 954-893-0501

APPLICATION FOR PERMIT

<p>Board of Supervisors Coral Springs Improvement District 10300 NW 11th Manor Coral Springs, FL 33071</p>		<p>Permit Type</p> <p><input checked="" type="checkbox"/> Right of Way <input type="checkbox"/> Surface Water Management <input type="checkbox"/> General</p>
--	--	--

1.	<p>PROPOSED USE OF DISTRICT FACILITY: <u>Telecommunication / MCI Metro Acc</u></p>						
2.	<p>LOCATION OF WORK: <u>1.Canal L-102 (N University Dr) 2.L-104 (N University Dr)</u></p>						
	<p><u>3. Canal L-106 (N University Dr)</u></p>						
	<table border="0"> <tr> <td style="text-align: center;">Subdivision</td> <td style="text-align: center;">Lot No.</td> <td style="text-align: center;">Block No.</td> </tr> <tr> <td>Section: <u>21/22/28/33</u></td> <td>Township: <u>48S</u></td> <td>Range: <u>41E</u></td> </tr> </table>	Subdivision	Lot No.	Block No.	Section: <u>21/22/28/33</u>	Township: <u>48S</u>	Range: <u>41E</u>
Subdivision	Lot No.	Block No.					
Section: <u>21/22/28/33</u>	Township: <u>48S</u>	Range: <u>41E</u>					
3.	<p>DISTRICT WORKS INVOLVED IN PROPOSED CONSTRUCTION OR USE:</p>						
4.	<p>NAME, ADDRESS, PHONE AND FAX OF OWNER OF PROPOSED WORK OR STRUCTURE:</p>						
	<p><u>MCImetro Access Transmission Services Corp</u> <u>16563 NW 15TH AVE Miami FL 33169 305-356-3160</u></p>						
5.	<p>NAME, ADDRESS, PHONE AND FAX OF APPLICANT OTHER THAN OWNER (If any):</p>						
	<p><u>Mastec North America / 954-292-7612</u> <u>10441 SW 187th Street Miami FL 33157 954-292-7612</u></p>						
6.	<p>AREA PROPOSED TO BE SERVED: (Give property description sufficient for identification,</p>						
	<p><u>BHPine Trails Park - Kimberly Mr Bills - Segment 2</u></p>						
7.	<p>This application, including sketches, drawings or plans and specifications attached, contains a full and complete description of the work proposed or use desired of the above described facilities of the District and for which permit is herewith applied. It shall be part of any permit that may be issued. It is agreed that all work or the use of the District's facilities involved will be in accordance with the permit to be granted and with the Permit Criteria Manual heretofore adopted by the District, which have been examined and are understood by the applicant and as the same may be hereafter from time to time amended, changed or revised and which (it is further understood) shall be incorporated in reference as a part of any permit which may be granted.</p>						

Standard Conditions ARE AS FOLLOWS:

1. In the event the DISTRICT wishes to obtain the ingress or egress to its property, easement or right of way affected by the permit issued pursuant to this application for any lawful District purpose, including but not limited to maintenance of any lake, canal or related water management infrastructure, the removal, demolition and reconstruction, if any, of the proposed work or structure permitted hereunder shall be at the sole expense of the owner or the owner's successors or assigns.
2. Permittee, by acceptance of the permit, covenants and agrees that the DISTRICT, District Managers, district consultants and its successors shall be promptly indemnified, defended, protected, exonerated, and saved harmless by the Permittee from and against all expenses, liabilities, claims, demands, and proceedings incurred by or imposed on said District in connection with any claim, proceeding, demand, administrative hearing, suit, appellate proceeding, or other activity; including unfounded or "nuisance" claims, in which the District may become involved, or any settlement thereof, arising out of any operations under this permit, including use of canal water for irrigation purposes, damage to landscaping, paint damage to automobiles, buildings, or other structures, and any property damage or personal injuries, fatal or non-fatal, of any kind or character.
3. Permittee agrees that no debris will be placed into the waterways of the District.

For this purpose the Permittee has submitted a check in the amount of Two-Thousand Five Hundred Dollars (\$2,500.00) which Permittee agrees to forfeit if debris is found to have been placed into the District's waterways; said determination to be at the sole discretion of the District and is acknowledged by Permittee to represent both actual and punitive damages for violating the provisions of this permit and, further, the provisions of Chapter 298, Florida Statutes.

If construction of the facilities called for in this permit have not been completed, an additional Two Thousand Five Hundred Dollars (\$2,500.00) will be submitted by Permittee to cover future occurrences of discharging builder debris into the District's waterways.

4. Applicant agrees to maintain the system in accordance with permit documents and to recertify the function, condition and operation of the system according to the District's schedule and submit "Storm water Inspection Reports" and shall comply with all re-inspection procedures required under the District's policies.
5. Applicant agrees to maintain adjacent canal/lake banks in accordance with the specified cross section, maintain permitted vegetation to the water's edge and keep the canal and canal bank free and clear of trash and debris.
6. Permittee agrees to correct any shoaling or erosion of district facilities resulting from the installation or operation of components authorized by the permit.
7. Applicant agrees to remove (and process permits for tree removal through the City of Coral Springs) any landscaping from adjacent canal rights of way other than grass or approved ground cover. The removal, mitigation, and permitting shall be at the applicant's own cost.
8. Abide by the terms and conditions of the permit.
9. To maintain works or structures in a good and safe condition.

- 10. To allow inspection at any time by the District of any works or structure established by permit upon notification.
- 11. Prevent the discharge of debris and/or aquatic weeds into any District works.
- 12. To maintain the water quality of all waters discharging into District works.
- 13. To conform with any alterations of or amendments to this manual, or those imposed by the DEP, SFWMD or EPA that may be deemed necessary by the District.
- 14. To make any immediate changes or repairs as requested by District personnel to insure the safe operation of the District's waterways during storm events.
- 15. Restore existing lake/canal banks to the design cross section of 4 Horizontal: 1 Vertical to 2 ft. below the control elevation.
- 16. Upon completion of the construction specified in the permit, the applicant shall submit to the District 3 as-built surveys and electronic media certified by a professional engineer, in a format generally compatible with the requirements of other storm water management jurisdictions.
- 17. Acknowledges that failure to maintain the system, comply with re-certification requirements, or performing construction with District authorization may result in the restriction or elimination of storm water discharges to District facilities.
- 18. No beneficial use of the property is allowed until the Coral Springs Improvement District has accepted the engineer's storm water management certification and released the project.

SPECIAL CONDITIONS WILL BE ADDED WHEN APPLICABLE:

Submitted this 02 day of may, 2019

Company and/or Owner: MCI metro access

By: 

Name: Donovan Carr

Title: project manager

BOARD OF SUPERVISORS
Reviewed and approved by Board meeting held

LOCATION MAP

CORAL SPRINGS, BROWARD COUNTY, STATE OF FLORIDA
TOWNSHIP 48S, RANGE 41E, SECTION 21, 22, 28, 33
FIBER OPTIC CABLE ROUTE FOR PINE TRAILS PARK - KIMBERLY MR BILLS



PROJECT: 1802BCWX.68	
BH: PINE TRAILS PARK - KIMBERLY MR BILLS, BROWARD COUNTY, FL	
CLARIFICATION NO.	QUANTITY



OUTSIDE PLANT CONSTRUCTION
TITLE: FIBER OPTIC CABLE ROUTE
BH: PINE TRAILS PARK - KIMBERLY MR BILLS
BROWARD COUNTY, FL

DATE: 02/15/19		
ENGINEER: CWSI		
DRAWN BY: D.H.		
REVISIONS		
DATE	DESCRIPTION	INITIAL
02/15/19	1ST SUBMITTAL	D.H. / D.T.
02/20/19	1ST REVISION	D.T.
03/01/19	2ND REVISION	D.T.

EXCEPT AS MAY BE OTHERWISE PROVIDED BY CONTRACT THESE DRAWINGS AND SPECIFICATIONS SHALL REMAIN THE PROPERTY OF MCI METRO, BOTH BEING ISSUED IN STRICT CONFIDENCE AND SHALL NOT BE REPRODUCED, COPIED, OR LENT FOR ANY PURPOSE WITHOUT SPECIFIC WRITTEN PERMISSION.

SCALE	
HORIZONTAL:	N.T.S.
VERTICAL:	N.T.S.
MP _____	TO MP _____
SHEET 02	OF 42
DWG: BH: PINE TRAILS PARK - KIMBERLY MR BILLS - 2019.dwg	

INDEX	
01 OF 42	— COVER
02 OF 42	— LOCATION MAP
03 OF 42	— GENERAL NOTES
04 OF 42	— CONTACT SHEET
05 OF 42	— SYMBOLS KEY
06 OF 42	— CONSTRUCTION DETAILS
07 OF 42	— STANDARD SIDEWALK DETAILS
08 OF 42	— MARKER POLE DETAIL
09 OF 42	— HANDHOLE DETAILS
10 OF 42	— CURB & GUTTER RESTORATION DETAILS
11 OF 42	— GENERAL NOTES AND CONCRETE SIDEWALK ON CURVED ROADWAYS DETAIL
12 OF 42	— CONCRETE SIDEWALKS ON FLUSH SHOULDER ROADWAYS DETAIL
13 OF 42	— PULL AND SPLICE BOX DETAIL
14 OF 42	— OUTSIDE PLANT FOCUS
15 OF 42	— CLARIFICATION SUMMARY SHEET
16 OF 42	— PLAN AND PROFILES
TO 33 OF 42	— F.D.O.T. PICTURES
34 OF 42	— F.D.O.T. PICTURES
TO 42 OF 42	— F.D.O.T. PICTURES

END PROJECT

STATION # 111+15
UNIVERSITY DR
BROWARD COUNTY
LAT/LONG: 26.2608, -80.25
TYPE: HANDHOLE.

START PROJECT

STATION # 0+00
NW 104 AVENUE
BROWARD COUNTY
LAT/LONG: 26.2319, -80.2532
TYPE: HANDHOLE.
SEGMENT 1 WILL TIE HERE.

FL - PMBRFL01 - 148325-EXECUTIVE TOWERS CORAL SPRING
Site-Span NFID 1801BSAQ.68
SITE TYPE: MACRO
LAT/LONG : 26.2339, -80.255

FL PMBRF01-000430-GL HOMES
1801BSAQ.67
SITE TYPE: MACRO
LAT/LONG: 26.2485, -80.2524

FL PMBRF01-000075-BELLSOUTH TREE TOWER
1001BSAQ.66
SITE TYPE: MACRO
LAT/LONG: 26.2524, -80.2798

FL - PMBRFL01 - 148076_52-VERIZON CORAL SPRINGS STORE OUTDOOR
Site-Span NFID 1801BSAQ.80
SITE TYPE: SMALL CELL
LAT/LONG : 26.2386, -80.2466

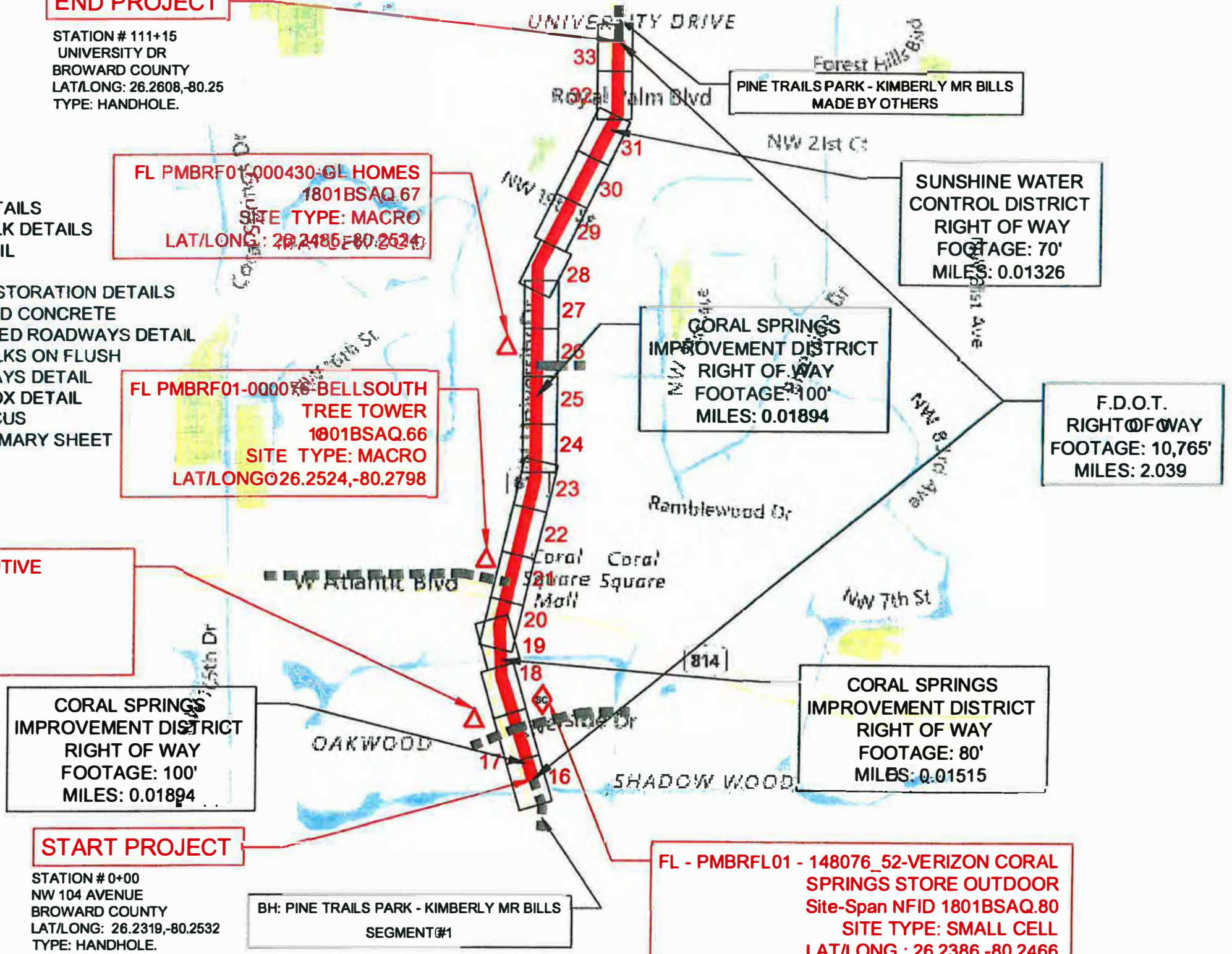

TOTAL FOOTAGE: 11,115'
TOTAL MILES: 2.105

- ▲ = MACRO
- ◊ = SMALL CELL
- = HANDHOLE
- = HUB

6B.

APPLICATION FOR PERMIT

Board of Supervisors Coral Springs Improvement District 10300 NW 11 th Manor Coral Springs, FL 33071		Permit Type <input checked="" type="checkbox"/> Right of Way <input type="checkbox"/> Surface Water Management <input checked="" type="checkbox"/> General
--	--	--

1.	PROPOSED USE OF DISTRICT FACILITY: <u>Proposed development of 11 multi-family units including water & sewer connections with on site drainage. Proposed continuation of NW 94th with associated drainage</u>									
2.	LOCATION OF WORK: <u>SE corner of intersection of NW 16th St and NW 94th Ave.</u>									
<table border="0"> <tr> <td data-bbox="198 735 748 777"><u>Coral Springs University Drive Subdivision Addition No. 1</u></td> <td data-bbox="748 735 990 777"><u>18, 19 and 20</u></td> <td data-bbox="990 735 1427 777"><u>J</u></td> </tr> <tr> <td>Subdivision</td> <td>Lot No.</td> <td>Block No.</td> </tr> <tr> <td>Section: <u>28</u></td> <td>Township: <u>48S</u></td> <td>Range: <u>41E</u></td> </tr> </table>		<u>Coral Springs University Drive Subdivision Addition No. 1</u>	<u>18, 19 and 20</u>	<u>J</u>	Subdivision	Lot No.	Block No.	Section: <u>28</u>	Township: <u>48S</u>	Range: <u>41E</u>
<u>Coral Springs University Drive Subdivision Addition No. 1</u>	<u>18, 19 and 20</u>	<u>J</u>								
Subdivision	Lot No.	Block No.								
Section: <u>28</u>	Township: <u>48S</u>	Range: <u>41E</u>								
3.	DISTRICT WORKS INVOLVED IN PROPOSED CONSTRUCTION OR USE: <u>N/A</u>									
4.	NAME, ADDRESS, PHONE AND FAX OF OWNER OF PROPOSED WORK OR STRUCTURE: <u>Logar Group, LLC located at 1151 Chenille Circle, Weston, FL 33327 Tel. (954) 663-3978</u>									
5.	NAME, ADDRESS, PHONE AND FAX OF APPLICANT OTHER THAN OWNER (If any): <u>N/A</u>									
6.	AREA PROPOSED TO BE SERVED: (Give property description sufficient for identification, <u>Folio #s: 484128011750, 484128011760, 484128011770</u>									
7.	This application, including sketches, drawings or plans and specifications attached, contains a full and complete description of the work proposed or use desired of the above described facilities of the District and for which permit is herewith applied. It shall be part of any permit that may be issued. It is agreed that all work or the use of the District's facilities involved will be in accordance with the permit to be granted and with the Permit Criteria Manual heretofore adopted by the District, which have been examined and are understood by the applicant and as the same may be hereafter from time to time amended, changed or revised and which (it is further understood) shall be incorporated in reference as a part of any permit which may be granted.									

Standard Conditions ARE AS FOLLOWS:

1. In the event the DISTRICT wishes to obtain the ingress or egress to its property, easement or right of way affected by the permit issued pursuant to this application for any lawful District purpose, including but not limited to maintenance of any lake, canal or related water management infrastructure, the removal, demolition and reconstruction, if any, of the proposed work or structure permitted hereunder shall be at the sole expense of the owner or the owner's successors or assigns.
2. Permittee, by acceptance of the permit, covenants and agrees that the DISTRICT, District Managers, district consultants and its successors shall be promptly indemnified, defended, protected, exonerated, and saved harmless by the Permittee from and against all expenses, liabilities, claims, demands, and proceedings incurred by or imposed on said District in connection with any claim, proceeding, demand, administrative hearing, suit, appellate proceeding, or other activity; including unfounded or "nuisance" claims, in which the District may become involved, or any settlement thereof, arising out of any operations under this permit, including use of canal water for irrigation purposes, damage to landscaping, paint damage to automobiles, buildings, or other structures, and any property damage or personal injuries, fatal or non-fatal, of any kind or character.
3. Permittee agrees that no debris will be placed into the waterways of the District.

For this purpose the Permittee has submitted a check in the amount of Two-Thousand Five Hundred Dollars (\$2,500.00) which Permittee agrees to forfeit if debris is found to have been placed into the District's waterways; said determination to be at the sole discretion of the District and is acknowledged by Permittee to represent both actual and punitive damages for violating the provisions of this permit and, further, the provisions of Chapter 298, Florida Statutes.

If construction of the facilities called for in this permit have not been completed, an additional Two Thousand Five Hundred Dollars (\$2,500.00) will be submitted by Permittee to cover future occurrences of discharging builder debris into the District's waterways.

4. Applicant agrees to maintain the system in accordance with permit documents and to recertify the function, condition and operation of the system according to the District's schedule and submit "Storm water Inspection Reports" and shall comply with all re-inspection procedures required under the District's policies.
5. Applicant agrees to maintain adjacent canal/lake banks in accordance with the specified cross section, maintain permitted vegetation to the water's edge and keep the canal and canal bank free and clear of trash and debris.
6. Permittee agrees to correct any shoaling or erosion of district facilities resulting from the installation or operation of components authorized by the permit.
7. Applicant agrees to remove (and process permits for tree removal through the City of Coral Springs) any landscaping from adjacent canal rights of way other than grass or approved ground cover. The removal, mitigation, and permitting shall be at the applicant's own cost.
8. Abide by the terms and conditions of the permit.
9. To maintain works or structures in a good and safe condition.

- 10. To allow inspection at any time by the District of any works or structure established by permit upon notification.
- 11. Prevent the discharge of debris and/or aquatic weeds into any District works.
- 12. To maintain the water quality of all waters discharging into District works.
- 13. To conform with any alterations of or amendments to this manual, or those imposed by the DEP, SFWMD or EPA that may be deemed necessary by the District.
- 14. To make any immediate changes or repairs as requested by District personnel to insure the safe operation of the District's waterways during storm events.
- 15. Restore existing lake/canal banks to the design cross section of 4 Horizontal: 1 Vertical to 2 ft. below the control elevation.
- 16. Upon completion of the construction specified in the permit, the applicant shall submit to the District 3 as-built surveys and electronic media certified by a professional engineer, in a format generally compatible with the requirements of other storm water management jurisdictions.
- 17. Acknowledges that failure to maintain the system, comply with re-certification requirements, or performing construction with District authorization may result in the restriction or elimination of storm water discharges to District facilities.
- 18. No beneficial use of the property is allowed until the Coral Springs Improvement District has accepted the engineer's storm water management certification and released the project.

SPECIAL CONDITIONS WILL BE ADDED WHEN APPLICABLE:

Submitted this 1 day of March, 2019

Company and/or Owner: Logar Village, LLC

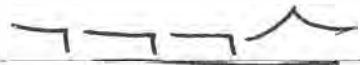
By: 

Name: Leonardo Manosalva

Title: Managing Member

BOARD OF SUPERVISORS
Reviewed and approved by Board meeting held

July 12, 2019

Ken Cassel, Manager
Coral Springs Improvement District
10300 NW 11th Manor,
Coral Springs, FL 33071

RE: Logar Village
NW 94th Avenue, South of 16th Street
Review of Storm Water Management Application

Ken:

Please find attached this office's recommendations for approval for on and off-site construction associated with Logar Village. Two storm water management licenses are required as on and off-site portions of this project will be owned and maintained by separate entities following construction. The design presented for NW 94th Avenue and on-site portions comply with District Criteria and we recommend approval.

I suggest the two storm water management licenses be considered (approved) together, as the on-site portion relies on off-site components for conveyance of runoff. Alternately the SWM license for NW 94th Avenue may be considered first.

Regards,

Glen A. Hanks, P.E.

August 12, 2019

Ken Cassel, Manager
Coral Springs Improvement District
10300 NW 11th Manor,
Coral Springs, FL 33071

RE: Logar Village – Off-site
NW 94th Avenue, South of 16th Street
Review of Storm Water Management Application

Ken:

This office reviewed the plans, details and calculations for Logar Village, signed and dated June 12, 2019 and found the storm water management system depicted and serving off-site portions of the development (portions of NW 94th Avenue) meet the requirements of the Coral Springs Improvement District as set forth in the Permit Criteria Manual. This office recommends approval of a storm water management license covering the improvement of NW 94th Avenue as depicted on plans prepared by Pillar Consultants.

Background

Logar Village, located on NW 94th Avenue, South of 16th Street is presently vacant. Utilities were installed in the right of way for NW 94th Avenue, however the NW 94th Avenue was not improved.

Proposed Work

The development depicted on plans and calculations by Pillar Consultants, Inc. reflects the improvement of 540 LF of NW 94th Avenue immediately south of NW 16th Street. The improvements depicted include paving, curbs, inlets, culverts, exfiltration trench and roadside swales. Work within the right of way of NW 94th Avenue will be transferred to and be the responsibility of the City of Coral Springs, following completion of the project.

Applicable Criteria

This portion of NW 94th Ave is required to provide

- 1/2" of dry pretreatment,
- Full water quality treatment
- Storage at or below the 10-year flood elevation equal to the basin required storage plus runoff resulting from the 10-year storm event falling on the excess impervious area

Logar Village – NW 94th Avenue

August 12, 2019

Page 2

- Storage at or below the 100-year flood elevation equal to the basin required storage plus runoff resulting from the 10-year storm event falling on the excess impervious area
- Provide a pollution retardant baffle prior to discharge to the District's facilities

Approach

Plans and calculations submitted for this project depict:

- 0.67 AC of road right of way
- 0.32 AC of paving
- 0.05 AC of sidewalk
- 0.3 AC of roadside swales, and
- 65 LF of 5'Hx8'W exfiltration trench providing 0.96 AC-In (0.08 AF) of water quality treatment, meeting water quality treatment requirements

Analysis

The proposed improvements to NW 94th Avenue depicted on plans submitted by Pillar Consultants for Logar Village comply with the requirements set forth in the Permit Criteria Manual for water quality treatment and storage. This office recommends approval of a storm water management license authorizing construction of 0.32 AC of roadway on 0.67 AC of right of way, providing water quality treatment and storage consistent with District requirements.

Regards,

Glen A. Hanks, P.E.

August 12, 2019

Ken Cassel, Manager
Coral Springs Improvement District
10300 NW 11th Manor,
Coral Springs, FL 33071

RE: Logar Village
NW 94th Avenue, South of 16th Street
Review of Storm Water Management Application

Ken:

This office reviewed the plans, details and calculations for Logar Village, signed and dated June 12, 2019 and found the storm water management system depicted and serving on-site portions of the development, meets the requirements of the Coral Springs Improvement District as set forth in the Permit Criteria Manual. This office recommends approval of a storm water management license covering on-site portions.

Background

Logar Village, located on NW 94th Avenue, South of 16th Street is presently vacant. Utilities were installed in the right of way for NW 94th Avenue, however the NW 94th Avenue was not improved.

Proposed Work

The development depicted on plans and calculations by Pillar Consultants, Inc. reflects the development of 11 townhouse units on 0.93 acres of presently vacant land. Lots 16 and 17, while under common ownership are to be developed separately, are excluded from this permit and to remain vacant. Prior to any construction on lots 16 and 17, separate approval from permitting. This phase of Logar Village, exceeds the impervious ratio accommodated in the master permit. The developer proposes additional storage to off-set additional impacts from impervious areas in excess of that accommodated by the District's system.

Applicable Criteria

This project located in the East Basin is required to provide

- 1/2" of dry pretreatment,
- Full water quality treatment

Logar Village, On-site portions

August 12, 2019

Page 2

- Storage at or below the 10-year flood elevation equal to the basin required storage plus runoff resulting from the 10-year storm event falling on the excess impervious area
- Storage at or below the 100-year flood elevation equal to the basin required storage plus runoff resulting from the 10-year storm event falling on the excess impervious area
- Provide a pollution retardant baffle prior to discharge to the District's facilities

Approach

Plans and calculations submitted for this project depict:

- 0.26 AC of building
- 0.26 AC of paving and patios, and
- 0.41 AC of pervious area
- 160 LF of 4'Hx6'W exfiltration trench providing 0.96 AC-In (0.08 AF) of water quality treatment, meeting water quality treatment requirements
- Minimum perimeter elevations of 11.8 ft. NAVD
- Controlled (restricted) discharges to accommodate required storage for the 10 and 100-year storms plus offsetting storage for additional impervious areas at elevations higher than prescribed in the Permit Criteria Manual

Analysis

The plans submitted for Logar Village comply with the requirements set forth in the Permit Criteria Manual for water quality treatment and storage. This office recommends approval of a storm water management license covering on-site portions of the development and authorizing construction of 0.26 AC of building, 0.26 AC of paving and other impervious areas, and 160 ft. of 4'Hx6'W exfiltration trench on a 0.93 AC site, consistent with District criteria.

Regards,

Glen A. Hanks, P.E.

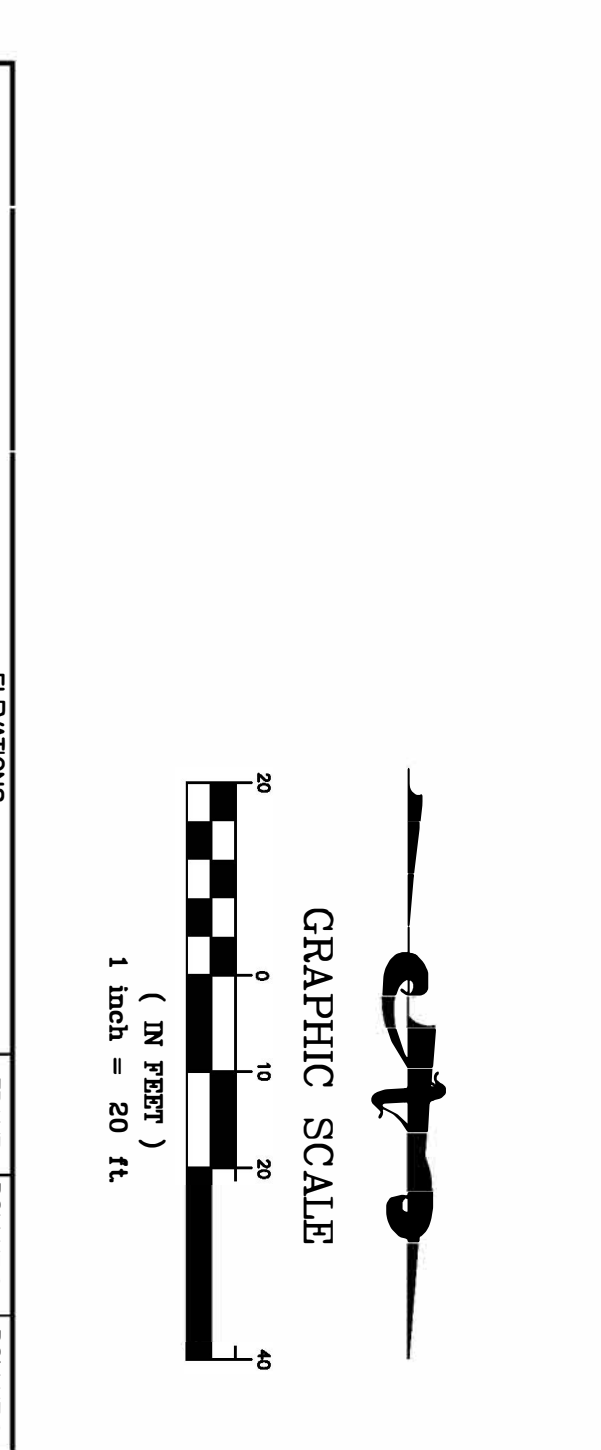
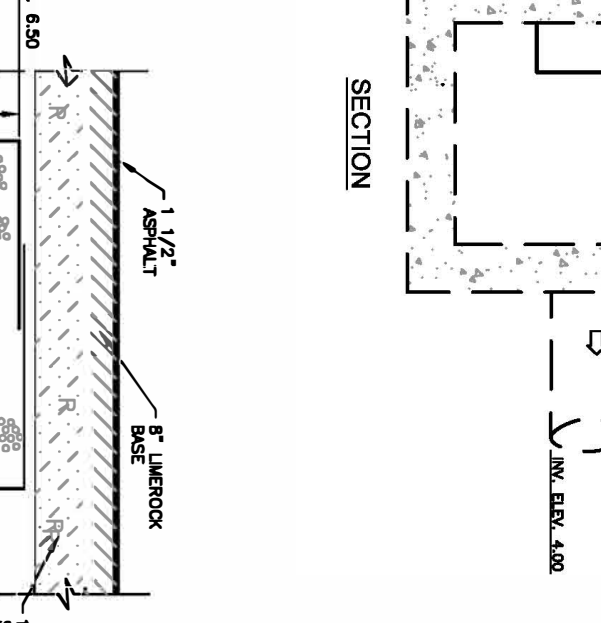
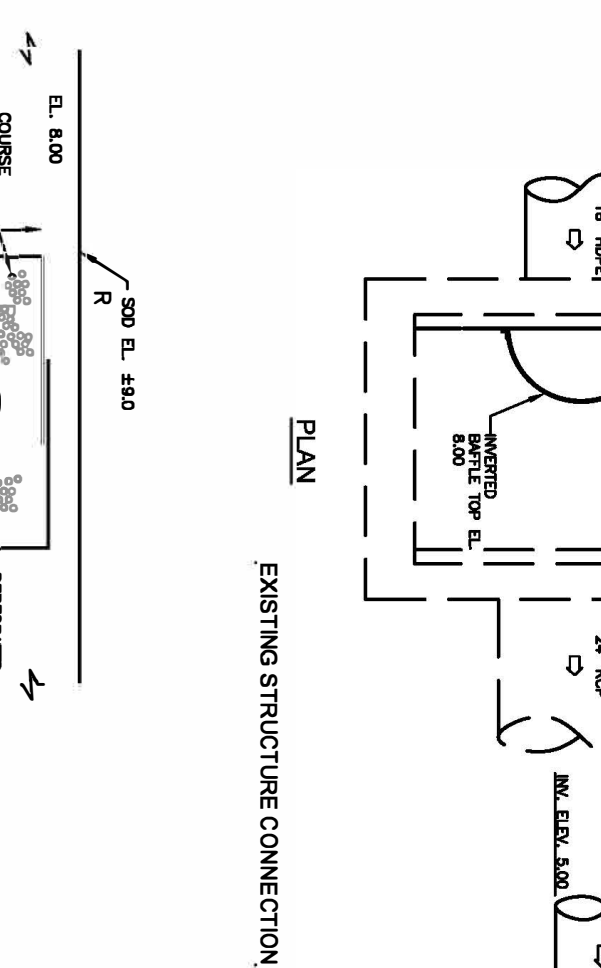
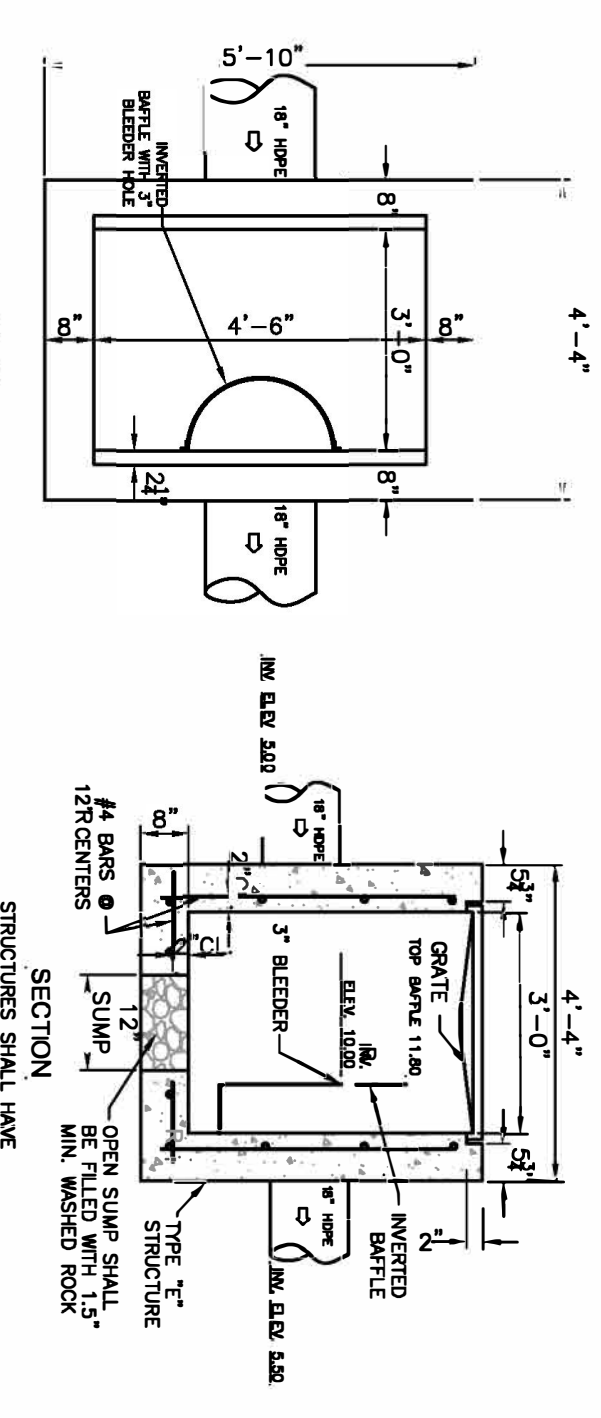
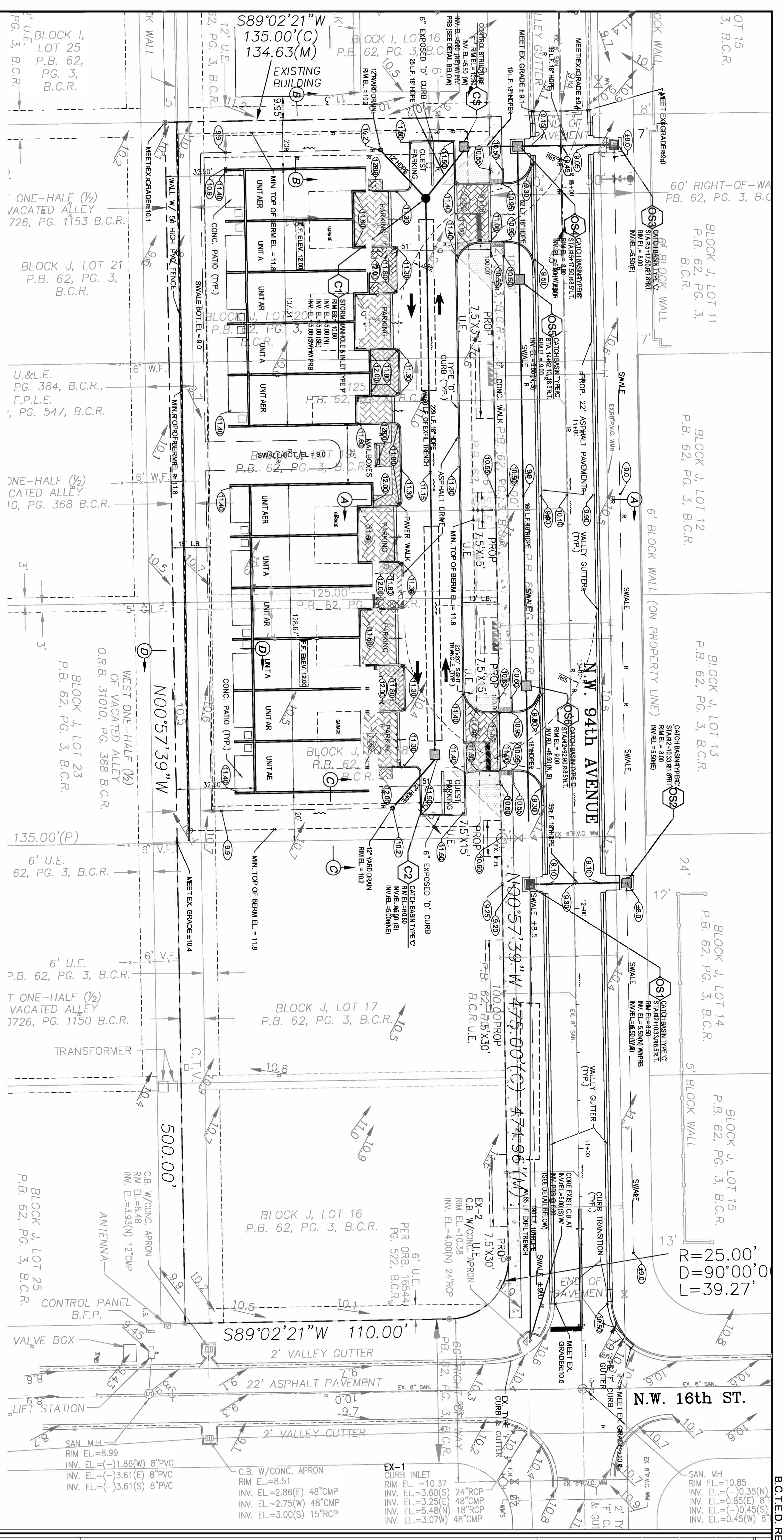

STRUCTURE NUMBER	TYPE	GRADE OR RIM / ELEV.	DEPTH / ELEV.	SPREAD / ELEV.	LOCATION	FRAME AND GRATE	POLLUTION BATTLE SIZE
C-1	MANHOLE TYPE 'C'	10.80	5.00	5.80	SW	3'00	30" x 30"
C-2	C.S. TYPE 'C'	10.80	5.00	5.80	NE	3'00	30" x 30"
C-3	C.S. TYPE 'C'	12.80	5.00	5.80	NW	3'00	30" x 30"
OS1	C.B. TYPE 'C'	8.80	5.50	5.50	N	3'30	24" x 30"
OS2	C.B. TYPE 'C'	8.00	5.50	5.50	N	3'30	24" x 30"
OS3	C.B. TYPE 'C'	8.00	5.50	5.50	N	3'30	24" x 30"
OS4	C.B. TYPE 'C'	8.00	5.50	5.50	N	3'30	24" x 30"
OS5	C.B. TYPE 'C'	8.00	5.50	5.50	N	3'30	24" x 30"
EX-1	EX. CURB INLET	10.37	3.00	3.25	E	3'07	24" x 30"
EX-2	EX. C.B.	10.38	4.00	4.00	S	-	24" x 30"

- LEGEND:**
- BOR: BROWARD COUNTY RECORDS
 - PLAT BOOK: PLAT BOOK
 - WATER METER: WATER METER
 - SAINTARY RECORDS BOOK: SAINTARY RECORDS BOOK
 - RIGHT-OF-WAY: RIGHT-OF-WAY
 - SECTION: SECTION
 - WOOD POWER POLE: WOOD POWER POLE
 - EXIST. WOOD POWER POLE: EXIST. WOOD POWER POLE
 - PROP. WOOD POWER POLE: PROP. WOOD POWER POLE
 - ANCHOR: ANCHOR
 - FRAMING FLOOR: FRAMING FLOOR
 - LANDSCAPE BUFFER: LANDSCAPE BUFFER
 - UTILITY EMBANKMENT: UTILITY EMBANKMENT
 - NOTE: CITY WILL NOT MAINTAIN PROPOSED PAVING
 - BRICK DRAINWAY IN PUBLIC RIGHT-OF-WAY: BRICK DRAINWAY IN PUBLIC RIGHT-OF-WAY
- NOTED:**
- MANUAL ON UNIFORM TRAFFIC CONTROL DEVICES
 - WATER METER
 - BLOW OFF
 - SAINTARY RECORDS BOOK
 - RIGHT-OF-WAY
 - CATCH BASIN
 - PROPOSED ELEVATION
 - EXIST. WOOD POWER POLE
 - PROP. WOOD POWER POLE
 - ANCHOR
 - FRAMING FLOOR
 - LANDSCAPE BUFFER
 - UTILITY EMBANKMENT
- ENGINEER'S SEAL:** NOT VALID WITHOUT ORIGINAL SIGNATURE

PROFESSIONAL ENGINEER

STATE OF FLORIDA

NO. 39461

PAVING GRADING & DRAINAGE PLAN

SHEET TITLE

LOGAR VILLAGE

CITY OF CORAL SPRINGS
BROWARD COUNTY, FLORIDA

PILLAR CONSULTANTS, INC.
Consulting Engineers, Planners, Surveyors

5230 S. University Drive - Suite 104
Davie, Florida 33328
Phone: (954) 680-6533

P.E. # 39461

DATE: 09/17/18
DRAWN BY: BAM
SHEET NO. C-1
77009

Seventh Order of Business

GENERAL FUND

PROPOSED BUDGET

FY 2019 / 2020

Table of Contents

- I. INTRODUCTION**
 - A. About the District 2-3
 - B. Development of the District Budget 4

- II. BUDGET HIGHLIGHTS**
 - A. Proposed Budget.....5-7
 - B. Budget Narrative.....8-17

ABOUT THE DISTRICT

The Coral Springs Improvement District (CSID or “The District”) was incorporated in 1970 for the purpose of constructing and maintaining systems of drainage, flood control within the boundaries of the District.

The District was formed enabling the development of the Southern portion of the City of Coral Springs. This was only possible by providing drainage to that land. The District levies and collects non-ad valorem assessments for the purpose of maintenance, operation and repair of the stormwater management system.

The primary responsibility of the stormwater management department is to prevent flooding throughout the District. Stormwater runoff is conveyed to canals via street drains which are maintained by the City of Coral Springs and/or private HOA’s.

CSID monitors and adjusts the water levels in 22 miles of canals, and is responsible for maintenance therein. The District keeps vegetation growth in the canals under control through chemical and biological (natural) methods, and routinely removes debris of all kinds from canals.

The District maintains and operates two pump stations, each capable of pumping 200,000 gallons per minute.

Coral Springs Improvement District has continuously improved and performed Canal Bank Restorations. The District corrected failing canal banks in 7 locations, constructed improvements for 4,000 linear feet of canal bank and spent \$6.12 million from reserves to complete this job.

DEVELOPMENT OF THE DISTRICT'S BUDGET

The District has historically operated, maintained, improved and expanded its stormwater drainage system through the General Fund budget. All operating and capital costs for the system have been funded by revenues generated through an assessment program.

The District's General Fund budget is a product of a financial plan adopted and approved by the Board of Supervisors. Any amendments to the budget are reflected in the amended budget.

The General Fund budget is prepared on a basis consistent with generally accepted accounting principles (GAAP).

Coral Springs Improvement District

General Fund

Proposed Budget

Fiscal Year Ending 2019-2020

Description	Adopted Budget 2018/19	Actual thru 3/31/2019	Proposed Next 6 Months	Total Projected thru 9/30/2019	Proposed Budget 2019-2020
REVENUES					
Assessment Revenues (Net)..budgeted	3,849,956	3,224,132	625,824	3,849,956	3,849,956
Assessment Revenues..excess collected	-	-	-	-	-
Permit Review Fees	1,000	2,200	-	2,200	1,000
Miscellaneous Revenue	-	8,746	308	9,054	-
Interest Income	20,000	54,955	27,755	82,710	20,000
Unrealized Gain (Loss)-SBA	-	-	-	-	-
Shared Personnel Revenue	33,896	16,946	16,946	33,892	34,912
Carry Forward Assigned Funds	92,885	-	92,885	92,885	-
Total Revenues	3,997,737	3,306,979	763,718	4,070,697	3,905,868
EXPENDITURES					
Administrative					
Supervisor Fees	7,200	3,600	3,600	7,200	7,200
Salaries and Wages	133,908	68,506	68,506	137,012	162,726
Special Pay	238	238	-	238	281
FICA Taxes	10,796	5,540	5,540	11,080	13,000
Pension Expense	16,069	8,242	8,242	16,484	19,527
Health Insurance	54,611	26,550	26,550	53,100	63,655
Worker's Compensation Ins.	379	267	267	534	620
Engineering Fees	30,000	14,700	15,300	30,000	42,000
Legal Fees	60,000	31,723	30,000	61,723	84,000
Special Consulting Services	100,000	28,742	71,258	100,000	94,600
Annual Audit	10,500	8,000	2,500	10,500	10,600
Actuarial Computation-OPEB	2,772	-	2,772	2,772	2,772
Management Fees	57,313	28,657	28,656	57,313	59,032
Telephone Expense	3,334	1,666	1,668	3,334	3,434
Postage	668	332	336	668	688
Printing & Binding	1,260	630	630	1,260	1,298
Administrative Building Costs	12,000	6,000	6,000	12,000	12,360
Insurance	1,179	408	771	1,179	1,238
Legal Advertising	2,000	115	1,885	2,000	2,000
Contingencies	1,000	398	602	1,000	1,000
Paver Incentive Program	12,500	-	12,500	12,500	12,500
Computer Expense/Technology	29,400	8,340	21,060	29,400	29,400
Digital Record Management	1,000	-	1,000	1,000	1,000
Office Supplies	7,125	3,800	3,325	7,125	7,337
Dues, Subscriptions, etal.	7,800	175	7,625	7,800	7,875
Promotional Expense	8,400	-	8,400	8,400	4,800
Capital Purchases	-	-	-	-	-
Total Administrative	571,452	246,629	328,993	575,622	644,943

Description	Adopted Budget 2018/19	Actual thru 3/31/2019	Proposed Next 6 Months	Total Projected thru 9/30/2019	Proposed Budget 2019-2020
Field Operations					
Salaries & Wages	278,553	138,191	138,191	276,382	286,361
Special Pay	813	813	-	813	921
FICA Taxes	21,309	10,479	10,479	20,958	21,907
Pension Expense	33,426	16,576	16,576	33,152	34,363
Health Insurance	88,849	44,715	44,715	89,430	107,813
Worker's comp Ins	15,433	7,649	7,649	15,298	15,864
Water Quality Testing	3,000	1,076	1,076	2,152	3,000
Communications-Radios/Cellphones	1,872	803	803	1,606	2,022
Electric	1,411	636	780	1,416	1,458
Rentals and Leases	-	154	154	308	500
Insurance	14,846	7,376	7,376	14,752	15,290
R&M - General	54,010	34,172	31,000	65,172	74,250
R&M - Facility		1,096	1,100	2,196	3,000
R&M - Culvert Inspection & Cleaning	69,500	129,000	-	129,000	119,500
R&M - Canal Dredging & Maintenance	25,000	-	25,000	25,000	25,000
R&M - Vegetation Management	15,000	4,615	10,385	15,000	60,000
Oper Supplies - General	3,825	1,819	2,006	3,825	17,025
Oper Supplies - Chemicals	114,659	40,321	74,000	114,321	120,540
Oper Supplies - Uniform Rental	1,823	699	699	1,398	2,414
Oper Supplies - Motor Fuels	51,705	3,401	48,304	51,705	51,705
Dues, Licenses, Schools	3,752	1,692	2,000	3,692	3,842
Capital Outlay-Equipment	27,500	-	27,500	27,500	27,500
Capital Improvements	1,000,000	373,352	626,648	1,000,000	655,650
Total Field Operations	1,826,285	818,635	1,076,441	1,895,075	1,649,925
TOTAL EXPENDITURES	2,397,737	1,065,264	1,405,434	2,470,697	2,294,868
Excess Revenues Over Expenditures	1,600,000	2,241,715	(641,716)	1,600,000	1,611,000
Reserves					
Reserved for 1st Qtr Operating	350,000	350,000	-	350,000	361,000
Reserves for Designated Projects/Emergency	250,000	250,000	-	250,000	250,000
Storm Damages Reserves	1,000,000	1,000,000	-	1,000,000	1,000,000
Total Reserves	1,600,000	1,600,000	-	1,600,000	1,611,000
Excess Revenues Over Expenditures & Reserves	-	641,716	(641,716)	-	\$ -

Description	Adopted Budget 2018/19	Actual thru 3/31/2019	Proposed Next 6 Months	Total Projected thru 9/30/2019	Proposed Budget 2019-2020
-------------	------------------------	-----------------------	------------------------	--------------------------------	---------------------------

Fee Impact Examples

Parcel Type	Impervious Area	ERUs
Residential Dwelling - Tier 1	1,947	0.40
Residential Dwelling - Tier 2	3,423	1.00
Residential Dwelling - Tier 3	5,449	1.40
Residential Dwelling - Tier 4	6,792	1.81
Small Apartment Building	9,354	2.00
Large Apartment Building	178,965	75.20
Retail/Office	21,261	5.55
Big Box Store	188,748	49.24
Restaurant	55,191	14.40
Car Dealership	187,133	48.81

Source: General Fund Assessment Methodology Study - 5/2018

REVENUES:

Assessments

The District levies a Non-Ad Valorem Assessment on all taxable property within the Coral Springs Improvement District in order to fund operating and maintenance expenditures, and future reserves. Based on the following table:

Fee Impact Examples		
Parcel Type	Impervious Area	ERUs
Residential Dwelling - Tier 1	1,947	0.40
Residential Dwelling - Tier 2	3,423	1.00
Residential Dwelling - Tier 3	5,449	1.40
Residential Dwelling - Tier 4	6,792	1.81
Small Apartment Building	9,354	2.00
Large Apartment Building	178,965	75.20
Retail/Office	21,261	5.55
Big Box Store	188,748	49.24
Restaurant	55,191	14.40
Car Dealership	187,133	48.81

Source: Assessment Methodology Study – 5/2018

Permit Review Fees

Permit fees are based on prior year's revenues.

Interest Income

Interest is earned on cash balances in the District's funds on deposit in checking and money market accounts and in various certificates of deposit.

Shared Personnel Revenue

The District has entered into an interlocal agreement with Pinetree Water Control District. Under the provisions of that agreement the District provides the services of an appropriately licensed field supervisor to Pinetree. Budgeted revenue from this source is \$34,912.

EXPENDITURES

Administrative:

Supervisor Fees

Board of Supervisors may be compensated \$200 per meeting, not to exceed \$2,400 per year. Based on 3 supervisors and 12 meetings per year, the amount should not exceed \$7,200.

Salaries and Wages

The total amount of budgeted wages for this Fiscal Year is \$162,726.

Special Pay

Special pay is a holiday bonus based on number of years of service. Special pay is budgeted for \$281.

FICA Taxes

FICA tax is established by the law and currently is 7.65%. Based on salaries of \$162,726 and Supervisors Fees of \$7,200 FICA taxes are being budgeted for \$13,000.

Pension Expense

The pension plan was established whereby the employer contributes into the plan annually. Based on salaries of \$162,726 pension expense is budgeted for \$19,527.

Health Insurance

The District offers each employee Health, Life, Dental and Disability Insurance. In addition, the board members are provided Health and Dental Insurance only. The projected cost to be paid by the District for this fiscal year is \$63,655.

Worker's Compensation Insurance

The District's Worker's Compensation Insurance premium is budgeted for \$620.

Engineering Fees

The District contracts for general engineering services on an annual basis. Based on prior years' experience, the projected amount for this Fiscal Year is \$42,000.

Legal Fees

The District currently has a contract with Lewis Longman & Walker, P.A. as legal counsel for the District. This contract includes preparation for monthly board meetings, contract review, etc. Based on prior year's experience the projected amount for this Fiscal Year is \$84,000.

Special Consulting Services

The District will need to engage a consultant who specializes in legislative codification. Certain District limitations relating to bidding threshold requirements, efficiencies, gains and benefits inherent in contract administration, and supervisor compensation levels need to be revised and updated. Additional consulting may be needed to conduct workshop sessions involving staff and department managers. The total amount being budgeted is \$94,600.

Annual Audit

The District is required by Florida Statutes to arrange for an independent audit of its financial records on an annual basis. Based on the current activity level the amount is not expected to exceed \$10,600.

Actuarial Computation-OPEB

Florida Statutes require the employer to make health coverage available to retirees at the employer's group rate. The Governmental Accounting Standards Board requires a periodic actuarial assessment of the cost and liability associated with these benefits. In June 2017 GASB 75 replaced and expanded GASB 45 reporting requirements. The District is budgeting \$2,772 for this assessment.

Management Fees

This service includes \$59,032 in management and financial advisory services provided to the District under the Management Contract with Inframark.

Telephone

Telephone and fax machine expenses are budgeted for this Fiscal Year for \$3,434.

Postage

Mailing of agenda packages, overnight deliveries, correspondence, etc. The projected expense for this Fiscal Year is \$688.

Printing and Binding

Checks, stationary, envelopes, photocopies, etc. The projected expense for this Fiscal Year is \$1,298.

Administrative Building Costs

This expense represents the costs to operate and maintain the administration building. The projected amount for this cost is \$12,360.

Insurance

The District retains Egis Insurance & Risk Advisors as our Insurance Agent, who on a yearly basis arranges the placement of the District insurance for property, general liability, and inland marine coverage. The expected amount for this Fiscal Year should not exceed \$1,238.

Legal Advertising

The District does most of its legal advertising in the Sun-Sentinel. Expenses include monthly meetings, special meetings, public hearings, etc. Based on prior years' experience the amount should not exceed \$2,000.

Contingencies

The District is budgeting \$1,000 for various bank charges incurred on its accounts.

Paver Driveway Incentive Program

An incentive of \$250 payment each year to the first fifty District residents to replace a concrete or other impervious surface driveway with a pervious paver type driveway. Total budgeted is \$12,500.

Computer Expense/Technology

All the District's financial records, accounts payable are processed on a main frame computer owned by Coral Springs Improvement District Water and Sewer Fund. The budget amount for this technology is \$29,400 and includes the cost of digital record keeping for engineering/project plans.

Digital Record Management

The District is providing for the set up and maintenance of digital records of existing infrastructure as-builts as well as providing for the mapping of drainage assets. The amount being budgeted is \$1,000.

Office Supplies

Accounting and Administrative Supplies. Projected expense for this year is \$7,337.

Dues, Licenses, Subscriptions

An annual renewal fee to Florida Assoc. of Special Districts in the amount of \$3,000, an annual Special District fee to the Department of Community Affairs in the amount of \$175, on-going accounting and seminars totaling \$1,000, and \$3,700 for other management related training. The projected expense totals \$7,875.

Promotional Expense

The District circulates periodic newsletters for the purpose of keeping its residents informed of issues affecting them and may sponsor an open house event for educating District residents about the services being provided. The annual budget for this item is \$4,800.

Capital Purchases

There are no budgeted expenditures.

Field Operations:

Salaries and Wages

The total amount of budgeted wages for this Fiscal Year is \$286,361.

Special Pay

Special pay is a holiday bonus based on number of years of service. Special pay is budgeted for \$921.

FICA Taxes

FICA tax is established by the law and currently is 7.65%. Based on salaries of \$286,361 FICA taxes are being budgeted for \$21,907.

Pension Expense

The pension plan was established whereby the employer contributes into the plan annually. Based on salaries of \$286,361 pension expense is budgeted for \$34,363.

Health Insurance

The District offers the employees Health, Life, Dental and Disability Insurance. The projected cost to be paid by the District for this fiscal year is \$107,813.

Worker's Compensation Insurance

The District's Worker's Compensation Insurance premium is budgeted for \$15,864.

Water Quality Testing

Water Quality Testing is done to provide a guide for planning the aquatic plant control program and in addition provides indications of dangerous or threatening conditions. Based on last year's quarterly testing the amount is estimated to be \$3,000.

Communications-Radios/Cellphones

The District provides Nextel/Sprint telephones for the field employees. The following are the estimated costs for the budget year.

	<u>Yearly</u>
Field Supervisor	\$1,206
Truck No. 1	408
Truck No. 2	408
Total	\$2,022

Electric

The District currently has the following utility accounts with Florida Power and Light Co. for purposes of providing electricity to the District's two pump stations:

<u>Address</u>	<u>Yearly</u>
Pump Station # 1 - 121 N.W. 93 rd Terrace	\$ 758
Pump Station # 2 - 12000 S.W. 1 st Street	700
Total	\$ 1,458

Rentals and Leases

Payments related to a lease on a copy machine. The projected cost to be paid by the District for this fiscal year is \$500.

Insurance

The District retains Egis Insurance & Risk Advisors as our Insurance Agent, who on a yearly basis arranges the placement of the District insurance for property, general liability, and inland marine coverage. Based on the prior years' experience the expected amount for this Fiscal Year should not exceed \$15,290.

Repair & Maintenance - General

The following is a listing of the different repairs and maintenance needed for operations.

Vehicle Maintenance	\$ 5,000
Pump Station Repairs/Maintenance	35,955
Trash Pick-up Service	4,975
Canal Bank Mowing	6,000
Misc. Repairs	<u>22,320</u>
Total	\$ 74,250

Repair & Maintenance - Facility

Estimated costs for general facility maintenance are \$3,000.

Repair & Maintenance - Culvert Inspection and Cleaning

Culvert inspection and cleaning costs of \$119,500 are being budgeted this year.

Repair & Maintenance - Canal Dredging & Maintenance

Estimated costs for canal maintenance are \$25,000.

Repair & Maintenance – Vegetation Management

Prevention of growth of invasive vegetation in canal rights-of-way, with associated bank repair. This should not exceed \$60,000.

Operating Supplies - General

The following is a listing of the different operating supplies needed for operations.

Safety equipment	\$ 4,500
Grass eating triploid carp	12,000
Annual Waterway Cleanup Donation	<u>525</u>
Total	\$17,025

Operating Supplies - Chemicals

Estimated costs for chemicals for the budget year are \$120,540.

Operating Supplies - Uniform Rental / Purchase

Estimated costs for uniform rental / purchase including Employee Safety Boot Allowance for the budget year are \$2,414.

Operating Supplies - Motor Fuels & Propane

Estimated costs for motor fuels and propane for the budget year are \$51,705.

Dues, Licenses, Schools

Employees are required to have an Aquatic License. This expense includes the classes, licenses and all fees related to the employee obtaining an Aquatic License. This year's projected amount should not exceed \$3,842.

Capital Outlay-Equipment

Capital outlay for equipment is budgeted for \$27,500.

Capital Improvements

Capital improvements in the amount of \$655,650 are being budgeted for canal bank restoration assessment.

Reserves for 1st Quarter Operating

The amount of \$361,000 is reserved toward 1st quarter operation expenses.

Reserves for Assigned Projects and Emergencies

The reserve fund is established to set aside funds for projects designed to maintain the District's drainage assets and to provide for unexpected events/natural disasters that may occur other than those related to Hurricanes. This fiscal year the amount projected to be set aside is \$250,000.

Storms Damages Reserves

The district has established that 3 million dollars will be collected over the next three years to limit exposure of financial losses due to storms. The 1 million dollars represents 2/3 of our target goal.

7A

RESOLUTION 2019-6

**A RESOLUTION OF THE BOARD OF SUPERVISORS OF
THE CORAL SPRINGS IMPROVEMENT DISTRICT,
ADOPTING THE FINAL GENERAL FUND BUDGET FOR
FISCAL YEAR 2020**

WHEREAS, pursuant to Section 12 of Chapter 2004-249, Laws of Florida, the District Manager has heretofore prepared and submitted to the Board of Supervisors, for approval, the District's proposed General Fund Budget for the ensuing fiscal year, said proposed budget having been previously approved by the Board of Supervisors; and

WHEREAS, a public hearing was held on this 19th day of August, 2019, at which hearing members of the general public were given the opportunity to speak and the Board was able to hear any objections to the final budget prior to the adoption of the same; and

WHEREAS, notice of the public hearing on the adoption of the final budget was duly published as required by law; and

WHEREAS, the Board, having conducted said public hearing and having heard any objections and suggestions pertaining to the budget, has determined that it is in the best interests of the District and those residing within the District to adopt the Final General Fund Budget for Fiscal Year 2020.

NOW, THEREFORE, BE IT RESOLVED BY THE BOARD OF SUPERVISORS OF THE CORAL SPRINGS IMPROVEMENT DISTRICT, THAT:

Section 1. The recitals above are true and correct and are hereby made a part of this Resolution.

Section 2. The General Fund Budget heretofore submitted to and approved by the Board is hereby adopted as the final General Fund Budget of the District for Fiscal Year 2020.

Section 3. A verified copy of said final General Fund Budget shall be attached as an exhibit to this Resolution as Exhibit A and shall be included as part of the District's "Official Record of Proceedings."

Section 4. The District Manager shall transmit a copy of this Resolution to the proper public officials so that its purpose and effect may be carried out in accordance with the law.

Section 5. This Resolution shall become effective immediately upon adoption.

PASSED AND ADOPTED by the Board of Supervisors of the Coral Springs Improvement District, this 19th day of August, 2019.

Dr. Martin Shank, President

Kenneth Cassel, Assistant Secretary

Exhibit A

Fiscal Year 2020 Final Budget

7B

RESOLUTION 2019-7

A RESOLUTION OF THE CORAL SPRINGS IMPROVEMENT DISTRICT, LEVYING AND IMPOSING A NON AD VALOREM MAINTENANCE AND OPERATIONS SPECIAL ASSESSMENT FOR FISCAL YEAR 2020

WHEREAS, certain improvements existing within the Coral Springs Improvement District (the “District”) and certain costs of operation, repairs and maintenance are being incurred by the District; and

WHEREAS, the District Board of Supervisors (the “Board”) finds and has determined that the District's total General Fund maintenance and operations budget, taking into consideration other revenue sources during Fiscal Year 2020, will amount to approximately \$_____; and

WHEREAS, the Board further finds and has determined that the District’s total maintenance and operations during Fiscal Year 2020 will amount to \$_____; and

WHEREAS, the Board further finds that the non-ad valorem special assessments it levies and imposes by this Resolution for maintenance and operations on the parcels of property involved will reimburse and fund the District for certain special and peculiar benefits received by the benefitted properties flowing from the maintenance, operation and repair of the systems, facilities and services apportioned in a manner that is fair and reasonable, in accordance with the applicable assessment methodology; and

WHEREAS, the Board understands that this Resolution levies only the maintenance and operations assessments for Fiscal Year 2020, and that the President of the District, the District Manager or the designee of the District Manager, shall certify a total non-ad valorem assessment roll in a timely manner to the Tax Collector in and for Broward County for collection to include all assessments levied and approved by the District on the property for maintenance and operation special assessments; and

WHEREAS, the Board finds that there are, as provided in Exhibit A, attached hereto and made a part hereof, assessable units which are responsible for the aforesaid costs of operation, repairs and maintenance as indicated therein.

NOW THEREFORE, BE IT RESOLVED BY THE BOARD OF SUPERVISORS OF THE CORAL SPRINGS IMPROVEMENT DISTRICT OF BROWARD COUNTY, FLORIDA, THAT:

Section 1. The recitals above are true and correct and are hereby made a part of this Resolution.

Section 2. A special assessment for maintenance and operations as provided for in Chapter 2004-489, Laws of Florida is hereby levied upon the platted lots within the District, and each benefitted property shall pay its proportionate share of the maintenance and operations assessments so levied, as identified in Exhibit A.

Section 3. That the collection and enforcement of the aforesaid maintenance and operations assessments on platted lots shall be by the County Tax Collector serving as agent of the State of Florida in Broward County (“Tax Collector”) and shall be at the same time and in like manner as ad valorem taxes and subject to all ad valorem tax collection and enforcement procedures which attend the use of the official annual tax notice. All assessments levied by the District shall be subject to the same discounts as Broward County taxes.

Section 4. The levy and imposition of the maintenance and operations special assessments on platted lots included in the District, all of which shall be levied and certified as a total amount on the non-ad valorem assessment roll to the Broward County Property Appraiser and Tax Collector by the designee of the President of the Board on compatible medium no later than the 15th day of September 2019, which shall then be collected by the Tax Collector on the tax notice along with other non-ad valorem assessments from other local governments and with all applicable property taxes to each platted parcel of property.

Section 5. The President of the Board of the Coral Springs Improvement District hereby designates the District Manager to perform the certification duties with respect to the list of lands included in the District that must pay the maintenance and operations assessment levy. Said assessments shall be extended by the Broward County Property Appraiser on the Broward County tax roll and shall be collected by the Broward County Tax Collector in the same manner and time as the Broward County taxes. The proceeds therefrom shall be paid to the Coral Springs Improvement District.

Section 6. The District Manager shall transmit a copy of this Resolution to the proper public officials so that its purpose and effect may be carried out in accordance with law.

PASSED AND ADOPTED this 19th day of August 2019, by the Board of Supervisors of the Coral Springs Improvement District, Broward County, Florida.

Kenneth Cassel
Assistant Secretary

Dr. Martin Shank
President

Exhibit A

(to be completed by Assessment Department)

Eighth Order of Business

RESOLUTION 2019-8

A RESOLUTION OF THE BOARD OF SUPERVISORS OF THE CORAL SPRINGS IMPROVEMENT DISTRICT APPROVING THE PROPOSED WATER AND SEWER BUDGET FOR FISCAL YEAR 2020 AND SETTING A PUBLIC HEARING THEREON PURSUANT TO FLORIDA LAW

WHEREAS, the District Manager has heretofore prepared and submitted to the Board a proposed Water and Sewer Budget for Fiscal Year 2020; a copy of which is attached hereto as Exhibit A (“Budget”), and

WHEREAS, the Board of Supervisors has considered said proposed Budget and desires to set the required public hearing thereon;

NOW, THEREFORE BE IT RESOLVED BY THE BOARD OF SUPERVISORS OF THE CORAL SPRINGS IMPROVEMENT DISTRICT, THAT:

Section 1. The recitals above are true and correct and are hereby made a part of this Resolution.

Section 2. The Budget proposed by the District Manager for Fiscal Year 2020 is hereby approved as the basis for conducting a public hearing to adopt said budget.

Section 3. A public hearing on said approved Budget is hereby declared and set for the following date, hour and place:

Date: September 16, 2019
Hour: 4:00 p.m.
Place: District Offices
10300 NW 11th Manor
Coral Springs, Florida 33071

Section 4. The District Manager shall publish or have published notice of this public hearing in the manner prescribed by law.

Section 5. This resolution shall become effective immediately upon its adoption.

PASSED AND ADOPTED by the Board of Supervisors of the Coral Springs Improvement District, this 19th day of August, 2019.

Martin Shank, President

Kenneth Cassel, Assistant Secretary

Exhibit A

Proposed Water and Sewer Budget for Fiscal Year 2020



PROPOSED BUDGET 2019 | 2020

WATER & SEWER

CORAL SPRINGS
IMPROVEMENT
DISTRICT



CORAL SPRINGS IMPROVEMENT DISTRICT “**PROPOSED BUDGET 2019/2020**”

BOARD OF ELECTIVE SUPERVISORS

- Dr. Martin Shank, President
- Duane Holland, Vice President
- Leonard Okin, Secretary

MANAGEMENT

- Kenneth Cassel, District Manager
- William G. Capko, District Attorney
- Rick Olson, District Engineer
- Dan Daly, Director of Operations
- Jan Zilmer, Human Resources Director
- David McIntosh, Director of Utilities
- Marta Rubio, Director of Finance



CORAL SPRINGS IMPROVEMENT DISTRICT “PROPOSED BUDGET 2019/2020”

TABLE OF CONTENTS

PROFILE

4	About the District
5	District Boundaries
6-7	Distinguish Awards
8	Organization Chart
9-11	Water Department
12-14	Wastewater Management Department
15	Maintenance Department
16-17	Field Department

II. PROPOSED BUDGET

18-22	Proposed Budget
23-26	Revenues
27-34	Admin Expenses
35-40	Plant Expenses
41-45	Field Expenses
46	Debt Service



CORAL SPRINGS IMPROVEMENT DISTRICT “PROPOSED BUDGET 2019/2020”

ABOUT THE DISTRICT

The Coral Springs Improvement District (CSID or “The District”) was incorporated in 1970 under the provisions of Chapter 70-617, Laws of Florida, for the purpose of constructing and maintaining systems of drainage, flood control and water and sewer utilities within the boundaries of the District. Its utilities currently service approximately 9,500 customers.

The District is governed by a three-member Board of Supervisors who are elected by landowners within the District once every four years.



Coral Springs Improvement District
Nano Construction - 2012



09-02-12



CORAL SPRINGS IMPROVEMENT DISTRICT “PROPOSED BUDGET 2019/2020”

DISTRICT BOUNDARIES & NEIGHBORHOOD REPORT

CORAL SPRINGS ZIP CODE 33071

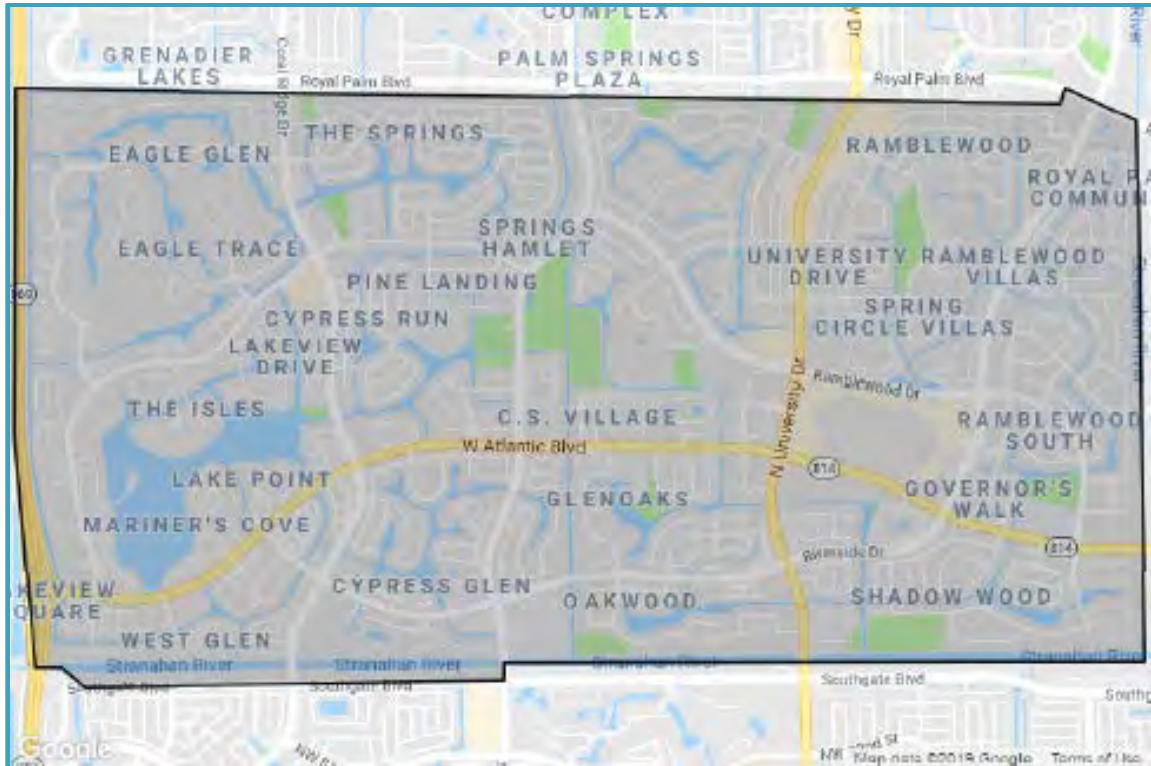

Coral Springs Improvement District

954-753-0729 csid@csidfl.org

10300 N.W. 11 Manor – Coral Springs, FL 33071

Covers all areas south of Royal Palm Boulevard to the C-14 canal.

According to Realtor Property Resources LLC report on 7/3/2019, the #1 dominant segment for this area are “Savvy Suburbanites” residents who are well educated, well read and well capitalized. This neighborhood most built between 1970 and 1990 are 91% owner occupied; 71% mortgaged with a median value of \$311,000 and low vacancy. 48.1% college graduated, and 76.1% with some college education. Well-connected consumers that appreciate technology; these are informed shoppers with residents who actively pursue sport activities. It is a neighborhood with multiple investors that are financially active, using multiple resources for informed investing.



CORAL SPRINGS IMPROVEMENT DISTRICT “PROPOSED BUDGET 2019/2020”

DISTINGUISHED AWARDS

Through the years, Coral Springs Improvement District (CSID) has obtained multiple awards; below are few of them.



2017 FSAWWA Award to the CSID Water Treatment Plant



2016 American Water Works Association Most Improved Class A Plant Award

2016 Certificate of Recognition to Water Treatment Plant for the outstanding Performance in Developing Plans for the on-going cost savings.



Plant Recovery – Zone

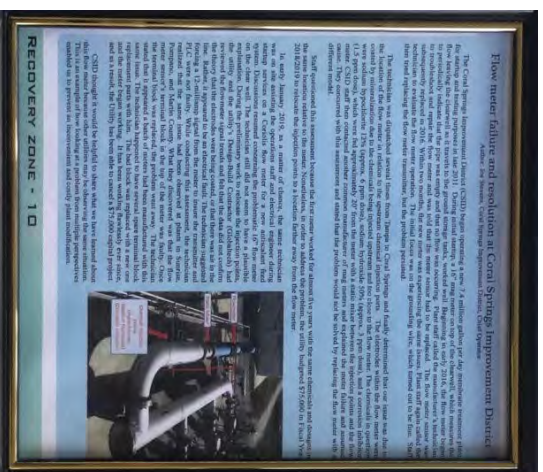



CORAL SPRINGS IMPROVEMENT DISTRICT "PROPOSED BUDGET 2019/2020"



2018 Award to Chief operator Joe Stephen's for outstanding operator of the year from the Southeast Desalting Association "SEDA"

Plant Recovery Zone - 10

RECOVERY ZONE - 5

When operators visit plantrooms they are provided with a variety of recovery zones. Recovery zones are designed to provide a safe and secure environment for operators to work in. Recovery zones are designed to provide a safe and secure environment for operators to work in. Recovery zones are designed to provide a safe and secure environment for operators to work in.

JLA Geosciences, Inc.
HYDROGEOLOGICAL CONSULTANTS
1907 Commercial Lane, Suite 104
Jupiter, Florida 33458
Phone: (861) 746-0228
www.jlageosciences.com

Post Treatment Workshop

On May 20th, SEDA held a post-treatment workshop that was hosted by the Coral Springs Improvement District (CSID). The workshop was held at the CSID facility, 1907 Commercial Lane, Suite 104, Jupiter, Florida.

2019 Southeast Desalting Association membrane plant of the year award.

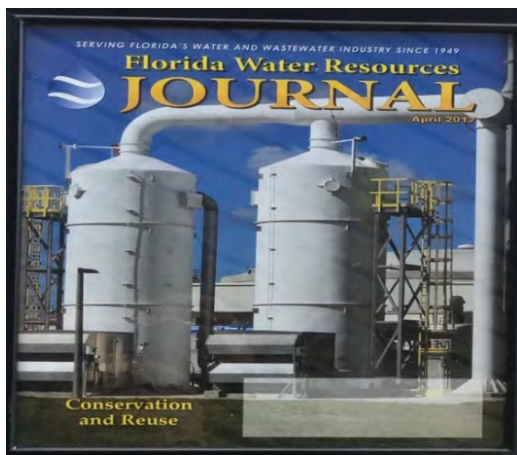



CORAL SPRINGS IMPROVEMENT DISTRICT "PROPOSED BUDGET 2019/2020"

ORGANIZATION CHART FISCAL YEAR 2019/2020

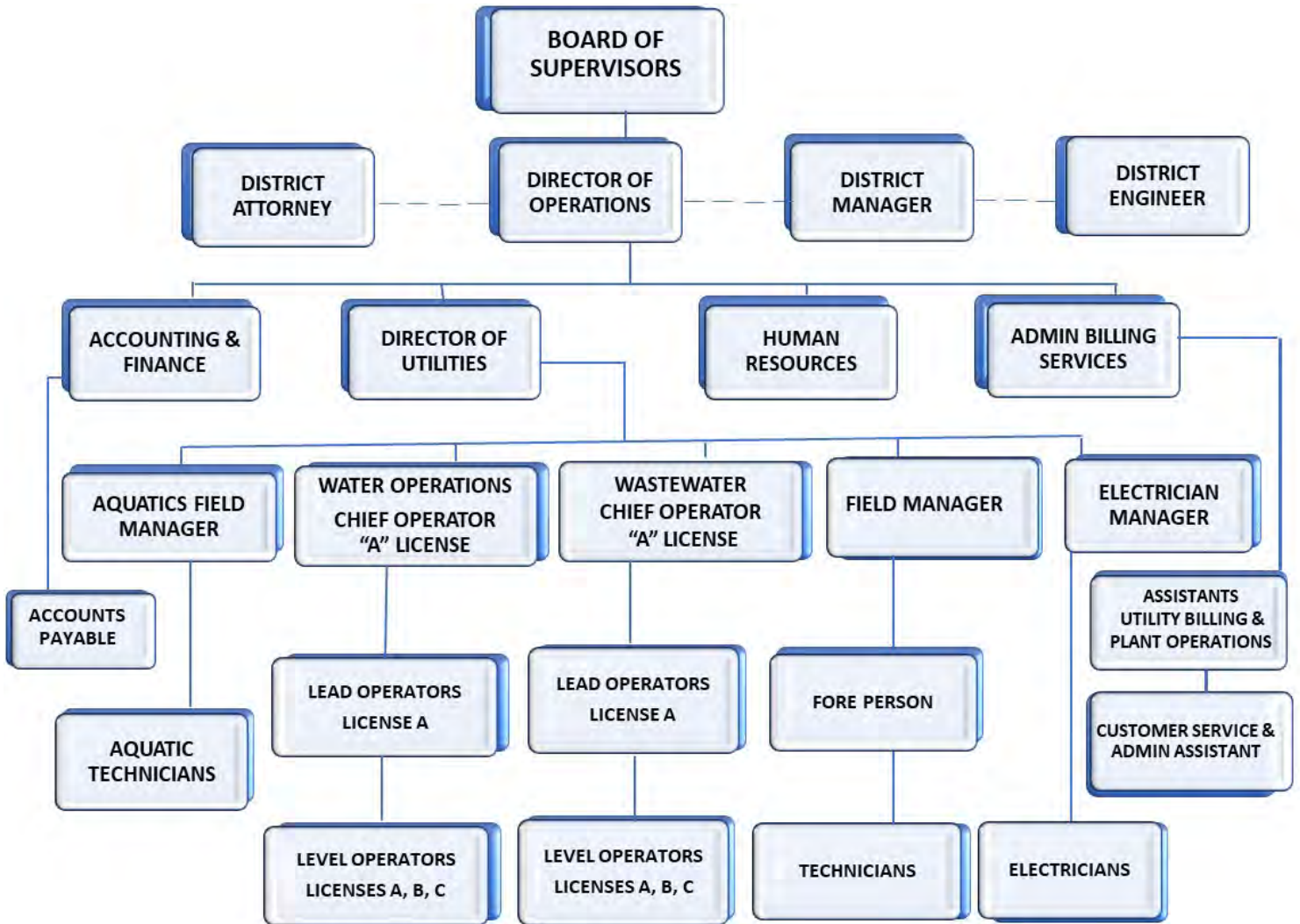



WATER DEPARTMENT

Water treatment is a complex process that is highly regulated by state and federal laws. Water treatment plant and system operators must be licensed and are required to undergo long-term, on-the-job training before becoming fully qualified. At CDIS, licensed water professionals have a basic understanding of a wide range of subjects, including mathematics, biology, chemistry, and physics. Some of the tasks they complete on a regular basis include:



- Operating and maintaining equipment to purify and clarify water;
- Monitoring and inspecting machinery, meters, gauges, and operating conditions;
- Conducting tests and inspections on water and evaluating the results;
- Maintaining optimal water chemistry;
- Applying data to formulas that determine treatment requirements, flow levels, and concentration levels;
- Documenting and reporting test results and system operations to regulatory agencies; and
- Serving our community through customer support, education, and outreach.

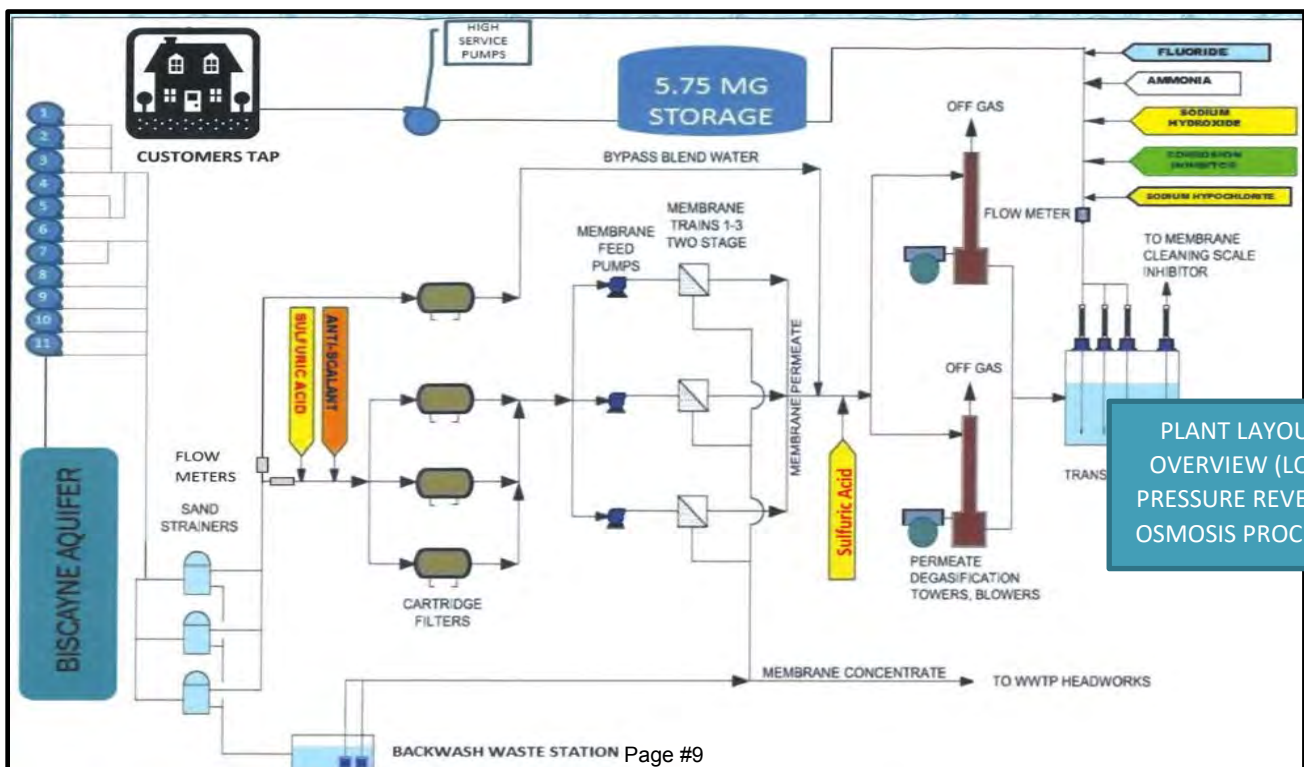



CORAL SPRINGS IMPROVEMENT DISTRICT “PROPOSED BUDGET 2019/2020”

Water Membrane Treatment

With many utilities facing threat of contamination from an increasing number of sources, the need for new and better ways to treat and protect water supplies is paramount. Membrane filtration has gained mainstream acceptance and is the preferred technology for many surface waters, for iron and manganese removal in ground waters, and for the removal of protozoans such as cryptosporidium. Membrane systems offer better removal of contaminants; higher efficiency, variable filtration ratings, consistent operation; and environment friendly to name some.



Loading new membranes into pressure vessels 2018



DEGASIFIERS



CORAL SPRINGS IMPROVEMENT DISTRICT “PROPOSED BUDGET 2019/2020”

WATER DEPARTMENT HIGHLIGHTS

- GIS indication of underground water line locations onsite including valves
- New well 4 on Atlantic Ave. established in 2014
- Well 6 submersible 316 stainless steel 50hp pump and motor being installed
- 4,000-gallon 93% sulfuric acid bulk tank
- 2,250,000 gallon per day reverse osmosis skid #3
- Degasifiers
- New bulk sodium hypochlorite tanks
- New fluoridation system covered mostly by a \$205,000 grant from the state
- 1,500 kw Cat generator which is capable of running the entire water plant at max capacity
- Lime softening plant circa 2014
- One-million-gallon storage tank
- Reverse Osmosis treatment facility
- 2016 American Water Works Association most improved class A plant award
- 2019 Southeast Desalting Association membrane plant of the year award.



WASTEWATER DEPARTMENT

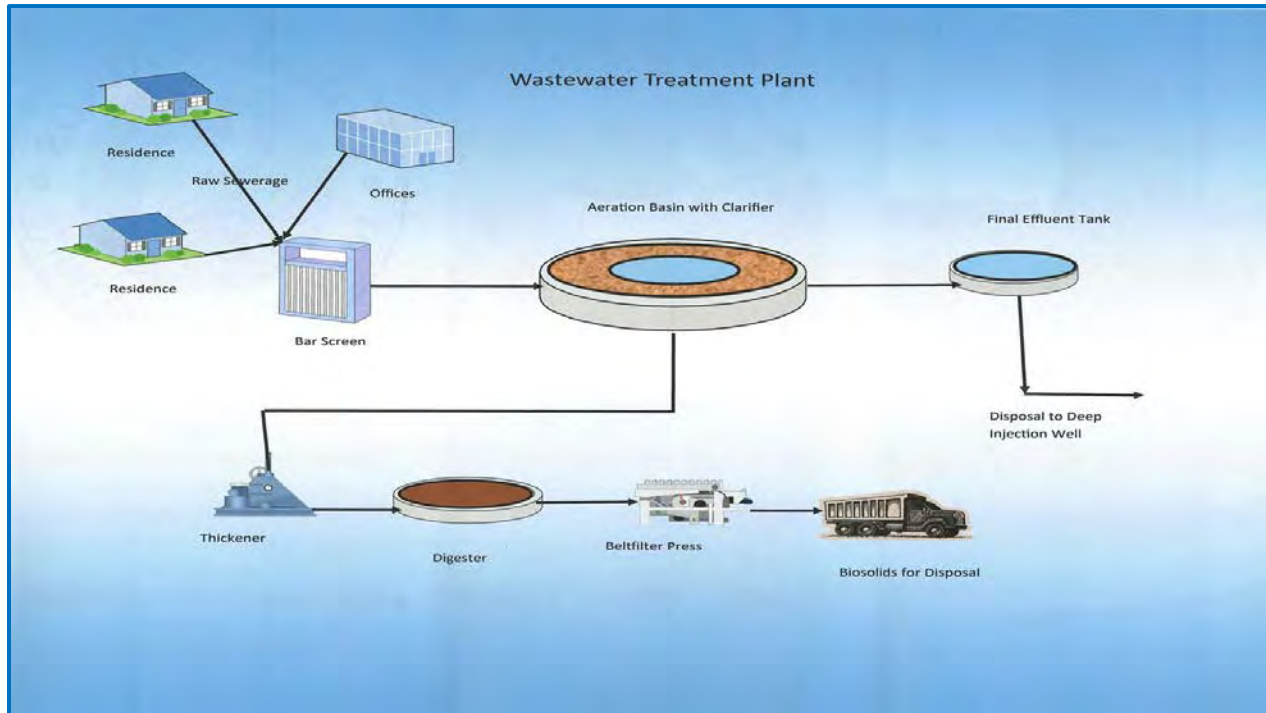

- Treats wastewater to regulatory standards
- Disposes of bio-solids and solid waste
- Disposes of treated wastewater through deep injection wells
- Maintains wastewater facilities

Wastewater Processing Plants

- Phase II of the ongoing Wastewater Treatment Plant expansion project has been completed. Among the items included in this 1.9-million-dollar project are an upgrade and replacement of information technology system, the rehab of sewage processing plants, new wastewater digester, environmentally compliant sludge processing equipment, and a state-of-the-art emergency generator/auxiliary power system.



CORAL SPRINGS IMPROVEMENT DISTRICT “PROPOSED BUDGET 2019/2020”

- The additional equipment and new facilities will give the District’s staff the ability to treat wastewater to a degree that will assure the highest level of treatment possible and continue District compliance with environmental and regulatory rules for years into the future.



Other projects recently completed:

- Replacing and upgrading aged facilities
- Evaluation of need to drill a new monitoring well to monitor the quality of wastewater effluent injected down the deep well.
- Demolishing two wastewater treatment plants that have operated years past their life expectancy.





CORAL SPRINGS IMPROVEMENT DISTRICT “PROPOSED BUDGET 2019/2020”

- Building a new treatment plant designed to replace the capacity of outdated Bar Screen Replacement.
- New Dual-Zone Monitoring Well for Injection Well #1
- Pond Liner Replacement.



- Effluent Pump Station Electrical Improvement
- Wastewater Plant D suffered structural damage sufficient to render it inoperable. The structural damage has to be repaired at a cost of \$1,445,731.40.





CORAL SPRINGS IMPROVEMENT DISTRICT “PROPOSED BUDGET 2019/2020”

Maintenance Department

Striving to cut costs and maintaining high quality of work, the District has used its own workforce to perform multiple in-house projects. Repairing sprinklers systems, painting, updating electrical panels, correcting mechanical problems, performing general repairs and upgrades, fixing equipment, installing & designing safety tools are just few of the tasks performed on a daily basis by employees from this department.





CORAL SPRINGS IMPROVEMENT DISTRICT “PROPOSED BUDGET 2019/2020”

Field Department

The field department personnel among other multiple construction projects, repairs and maintains all District water lines, about 1080 Valves, 675 fire hydrants, 9500ish meters and countless other Appurtenances relating to Drinking water. They ensure that the finished water that the water plant makes gets distributed to the customer safely, with sufficient volume and pressure, is accurately metered and maintains sufficient quality. They also collect wastewater. Returning it to the wastewater plant with similar goals in mind.

Respond, clear and clean up sewer backups, complete spill reports, water samples testing and reporting to Health department and county offices. Rebuild replace and maintain 90ish wastewater pumps, 41 lift stations and another couple hundred wastewater valves. Maintain the housekeeping and internal cleanliness of those 41 lift stations. This department maintain Atlas data for all of the above mentioned items in electronic and paper form, and diagnose and repair electrical, SCADA and pump related issues and respond to alarms.

The District provides An AMR system (Advance Metering Reading System), a comprehensive meter reading platform with fixed network-like performance, minus the infrastructure or cost. An AMR system gives water management tools with the convenience and flexibility of having premier drive-by technologyan authomated meter reading Drive-By system. Benefits:

- Enhanced customer service
- Accurate meter reading collection
- Improved water conservation
- Wireless Communication
- Reduced Meter Reading Times
- Increased efficiency
- Enhanced employee safety
- Leak, tamper, and reverse flow alarms





CORAL SPRINGS IMPROVEMENT DISTRICT "PROPOSED BUDGET 2019/2020"

Where does everything down the drain go??

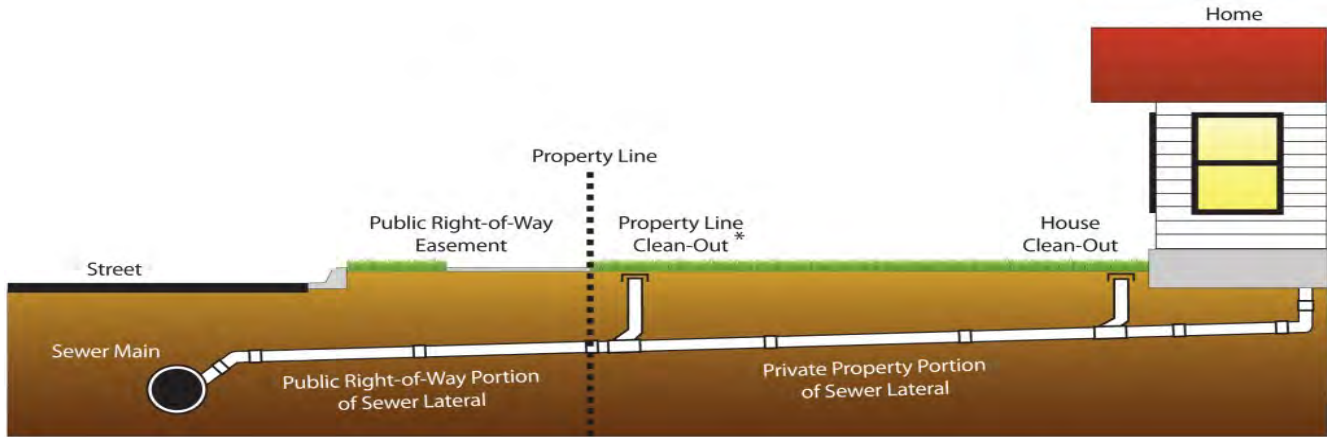

* Not standard on all properties.

THE TESLA 4 REGISTER IS EQUIPPED WITH THE LARGEST LCD IN THE INDUSTRY FOR EASY READING AT A DISTANCE OF 6 FEET. THE LCD PROVIDES A 10-DIGIT PROGRAMMABLE METER READ AND A 6 SEGMENT LEAK DETECTOR INDICATOR WITH FLOW DIRECTION ARROWS. FLOW RATE, WATER MOVEMENT, BATTERY STATUS, TAMPER, BACKFLOW, LEAK WARNING, AND TRANSMISSION INDICATOR ARE SHOWN ON THE LCD AS APPROPRIATE. STATUS INDICATORS ARE SENT AS PART OF THE AMR/AMI EXTENDED MESSAGE. THE LCD IS ALWAYS ACTIVE AND REQUIRES NO TOOLS FOR VISUAL READING

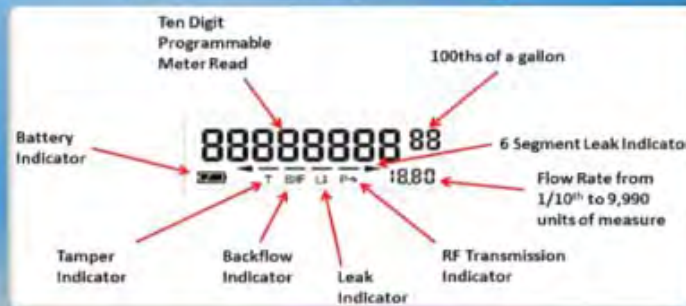



CORAL SPRINGS IMPROVEMENT DISTRICT “PROPOSED BUDGET 2019/2020”

PROPOSED BUDGET

The District’s annual budgets are adopted for the General Fund and Water & Sewer Fund and approved by the Board of Supervisors.

General Fund

The District has historically operated, maintained, improved and expanded its stormwater drainage system through the General Fund budget. All operating and capital costs for the system are funded by revenues generated through an assessment program.

The District already submitted a proposed budget for its General Fund which provided a none increase in the ad valorem assessments and it is intended to last for the coming two fiscal years. The current rates were initially adopted in Fiscal Year 2018/2019 and served the District for three consecutive years.

Water & Sewer

The Water & Sewer Fund is an enterprise fund established to account for operations that are to be financed and operated in a manner similar to private business enterprises. The cost of providing services to customers are to be recovered primarily through user charges.

In accordance with Section 189.069 (11) of the Florida Statute, Coral Springs Improvement District (CSID) management team present to you the Fiscal Year 2019/2020 Proposed budget for Water & Sewer Fund.

**CORAL SPRINGS IMPROVEMENT DISTRICT
Water and Sewer Enterprise Fund**

**PROPOSED BUDGET
Fiscal Year 2019 - 2020**

DESCRIPTION	ADOPTED BUDGET FY 2018-2019	ACTUAL THRU 4/30/2019	PROJECTED NEXT 5 Months	TOTAL PROJECTED THRU 9/30/2019	PROPOSED BUDGET FY 2019-2020
REVENUES					
Water Revenue	\$ 6,467,008	\$ 3,970,637	\$ 2,496,371	\$ 6,467,008	\$ 6,467,008
Sewer Revenue	5,852,977	3,524,859	2,328,118	5,852,977	5,852,977
Standby Revenue	3,120	1,780	1,271	3,051	3,120
Processing Fees	12,000	9,700	2,300	12,000	12,000
Lien Revenue Fees	9,000	9,725	-	9,725	9,000
Delinquent Fees	290,000	192,525	97,475	290,000	290,000
Contract Utility Billing Services	59,620	34,780	24,840	59,620	62,602
Contract HR & Payroll Services	12,902	7,527	5,375	12,902	13,289
Facility Connection Fees	-	22,720	-	22,720	-
Meter Fees	-	5,267	-	5,267	-
Line Connection Fees	-	21,400	-	21,400	-
Interest Income-Restricted	-	65,056	26,469	91,525	-
Interest Income-Operations	65,000	154,646	44,185	198,831	65,000
Rent Revenue	63,304	52,841	10,463	63,304	65,203
Technology Sharing Revenue	15,000	8,750	6,250	15,000	15,450
Miscellaneous Revenue	12,000	26,849	-	26,849	12,000
Renewal & Replacement	365,000	-	365,000	365,000	-
Carryforward Prior Yr Fund Balance	4,372,639	1,150,000	2,719,076	3,869,076	1,705,236
TOTAL REVENUES	17,599,570	9,259,062	8,127,193	17,386,255	14,572,885
EXPENDITURES					
Debt Service					
Principal 2016 Series	1,595,000	1,595,000	-	1,595,000	1,640,000
Interest 2016 Series	1,226,405	1,226,405	-	1,226,405	1,177,758
Sub-Total Debt Service	2,821,405	2,821,405	-	2,821,405	2,817,758

DESCRIPTION	ADOPTED BUDGET FY 2018-2019	ACTUAL THRU 4/30/2019	PROJECTED NEXT 5 Months	TOTAL PROJECTED THRU 9/30/2019	PROPOSED BUDGET FY 2019-2020
ADMINISTRATIVE					
Salaries and Wages	1,002,793	524,647	424,259	948,906	1,011,726
Special Pay	2,252	2,198	953	3,151	2,534
FICA Taxes	76,713	39,056	32,456	71,512	77,397
Pension Expense	120,335	62,294	50,911	113,205	121,408
Health Insurance	199,390	99,659	84,357	184,016	233,182
Workers Comp. Insurance	2,707	1,240	1,145	2,385	3,423
Unemployment Compensation	4,000	-	4,000	4,000	4,000
OPEB Expense	-	-	2,726	2,726	2,862
Engineering Fees	33,600	4,897	28,703	33,600	33,600
Trustee/Other Debt Expenses	10,740	9,159	1,581	10,740	10,720
Legal Fees	36,000	14,464	21,536	36,000	60,000
Special Consulting Services	90,570	58,350	50,000	108,350	86,000
Travel & Per Diem (Board)	4,500	-	4,500	4,500	4,500
Annual Audit	12,000	12,000	-	12,000	12,150
Actuarial Computation	2,700	-	2,700	2,700	2,700
Management Fees	85,973	50,187	35,786	85,973	88,552
Telephone Expense	12,810	7,710	5,100	12,810	13,835
Postage	36,200	17,876	18,324	36,200	36,600
Printing & Binding	21,970	8,675	13,295	21,970	21,970
Electric Expense	12,000	5,871	6,129	12,000	12,960
Rentals and Leases	3,075	1,545	1,530	3,075	3,075
Insurance	15,288	7,236	8,052	15,288	16,520
Repair and Maintenance	16,970	9,558	14,572	24,130	26,460
Legal Advertising	13,800	463	4,037	4,500	4,500
Other Current Charges	27,060	17,942	9,118	27,060	29,910
Merchant Fees	68,700	40,075	32,625	72,700	78,520
Computer/Technology Expenses	63,831	23,455	40,376	63,831	113,835
Employment Ads	18,840	1,380	12,170	13,550	13,550
Toilet Rebate [150 x \$99 = \$14,850]	14,850	4,356	10,494	14,850	14,850
Office Supplies	4,000	1,178	2,822	4,000	4,000
Dues, Licenses, Schools & Permits	12,000	1,615	10,385	12,000	12,000
Promotional Expenses	18,310	15,142	3,168	18,310	14,640
Capital Outlay	50,000	-	50,000	50,000	23,000
Sub-Total Administrative	2,093,977	1,042,228	987,809	2,030,037	2,194,979

PLANT OPERATIONS

DESCRIPTION	ADOPTED BUDGET FY 2018-2019	ACTUAL THRU 4/30/2019	PROJECTED NEXT 5 Months	TOTAL PROJECTED THRU 9/30/2019	PROPOSED BUDGET FY 2019-2020
Salaries and Wages	1,715,618	795,800	795,800	1,591,600	1,700,446
Special Pay	2,702	2,599	-	2,599	2,703
FICA Taxes	131,244	61,249	61,249	122,498	130,084
Pension Expense	203,124	90,114	90,114	180,228	201,000
Health Insurance	334,514	158,888	158,888	317,776	354,297
Workers Comp. Insurance	59,877	35,907	35,907	71,814	93,877
OPEB Expense	-	-	-	-	4,437
Water Quality Testing	72,066	33,326	38,740	72,066	68,475
Telephone	9,864	3,514	5,018	8,532	8,900
Electric	678,409	359,955	287,103	647,058	698,830
Rentals and Leases	13,900	859	13,041	13,900	15,500
Insurance	158,849	69,668	88,443	158,111	166,630
Repair & Maintenance	694,656	261,786	465,583	727,369	1,007,715
Filters for Water Plant	705,050	592,044	113,006	705,050	678,290
Sludge Management-Sewer	150,000	66,619	66,124	132,743	150,000
Chemicals	408,767	140,691	268,076	408,767	337,995
Operating Supplies	95,675	18,518	79,211	97,729	98,675
Office Supplies	2,765	1,916	1,719	3,635	3,635
Uniforms	9,255	3,667	5,974	9,641	9,775
Motor Fuels	81,756	7,711	74,045	81,756	99,411
Dues, Licenses & Permits	71,212	40,881	30,331	71,212	56,950
Capital Outlay	3,276,430	1,633,139	1,642,011	3,275,150	964,000
Renewal & Replacement	365,000	98,470	266,530	365,000	-
Sub-Total Plant Operations	9,240,733	4,477,321	4,586,913	9,064,234	6,851,625

DESCRIPTION	ADOPTED BUDGET FY 2018-2019	ACTUAL THRU 4/30/2019	PROJECTED NEXT 5 Months	TOTAL PROJECTED THRU 9/30/2019	PROPOSED BUDGET FY 2019-2020
FIELD OPERATIONS					
Salaries and Wages	748,175	374,332	374,332	748,665	786,613
Special Pay	1,459	1,245	-	1,246	1,405
FICA Taxes	57,235	28,428	28,428	56,856	60,176
Pension Expense	89,780	42,813	42,813	85,626	94,394
Health Insurance	206,450	101,584	101,584	203,168	247,480
Workers Comp. Insurance	34,864	24,645	24,645	49,291	49,556
OPEB	0	-	-	-	2,723
Water Quality Testing	1,000	-	1,000	1,000	1,000
Naturescape Irrigation Service	4,679	4,819	-	4,820	4,970
Telephone Expense	10,800	7,035	5,640	12,676	13,950
Electric Expense	114,735	52,665	53,329	105,994	114,480
Rent Expense	17,480	1,526	15,954	17,480	9,500
Rent Expense - SCADA	56,040	32,690	23,350	56,041	56,040
Insurance	22,206	9,131	13,075	22,206	24,000
Repairs and Maintenance	117,468	41,372	103,060	144,433	216,000
Lift Stations	168,850	59,533	109,317	168,850	168,850
Generators	26,083	11,682	14,401	26,083	33,080
Meters	49,340	14,470	34,870	49,341	60,680
Office Supplies	1,680	409	1,271	1,680	1,680
Operating Supplies	61,295	38,285	23,010	61,296	57,190
Uniforms	5,820	2,475	3,345	5,820	5,820
Motor Fuels	28,580	12,778	15,802	28,580	22,860
Dues, Licenses, Schools & Permits	13,296	6,408	6,888	13,296	13,300
Capital Outlay	1,324,000	650,911	673,089	1,324,000	381,000
Renewal & Replacement	-	-	-	-	-
Sub-Total Field Operations	3,161,315	1,519,236	1,669,203	3,188,451	2,426,747
TOTAL OPERATING EXPENDITURES	14,496,024	7,038,785	7,243,925	14,282,722	11,473,351
Required Reserve for R&R	-	-	-	-	-
TOTAL OPERATING EXPENDITURES & RESERVES	14,496,024	7,038,785	7,243,925	14,282,722	11,473,351
AVAILABLE FOR DEBT SERVICE	3,103,546	2,220,277	883,268	3,103,533	3,099,534
Debt Coverage Required 1.10	1.10			1.10	1.10
Debt Service Requirement 1.00	2,821,405			2,821,405	2,817,758
Projected Surplus .10	282,141			282,141	281,776
TOTAL DEBT SERVICES + SURPLUS	3,103,546			3,103,546	3,099,534



CORAL SPRINGS IMPROVEMENT DISTRICT “PROPOSED BUDGET 2019/2020”

REVENUES

Water & Sewer represent 93% of the District’s total income. Those utility rates have not increased since year 2012, and as a result, revenues will remain almost the same.

Revenues by Sources

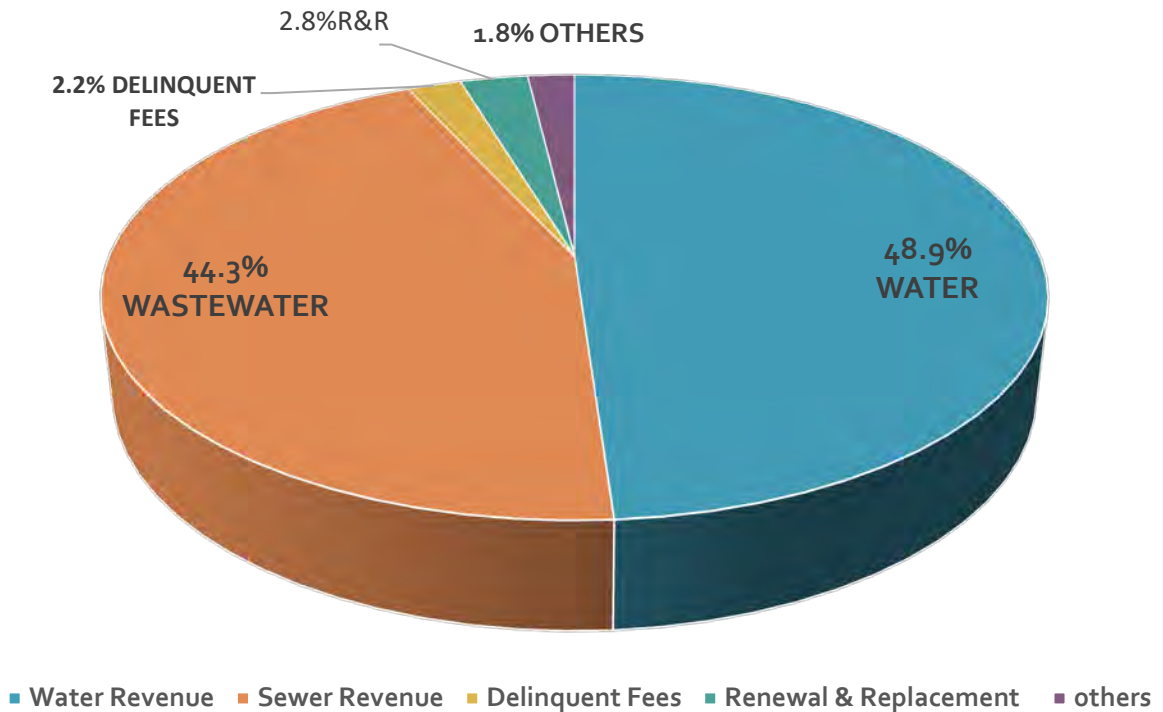

**CORAL SPRINGS IMPROVEMENT DISTRICT "PROPOSED BUDGET 2019/2020"**

Water & Sewer Revenues

The District will use reserve funds in the amount of \$1,705,236 to help offset infrastructure projects required by Plant & Field departments.

Water Revenue

The estimated amount that will be billed to users of the water system of the District is determined by the utility rate agreement. Based on prior year revenues the water revenues are projected to be \$6,467,008.

Sewer Revenue

The estimated amount that will be billed to users of the wastewater system of the District is determined by the utility rate agreement. Based on prior year revenues the sewer revenues are projected to be \$5,852,977.

Standby Revenue

The standby charge is applied to each lot, parcel or tract, which has been reserved for water and sewer capacity. The standby charges for this Fiscal Year are based on 13 units per month @ \$20 per unit. The amount projected for this Fiscal Year is \$3,120.

Processing Fees

A processing fee of \$20 is charged to each new utility account. Based on the District's history of new accounts, the projected amount for this fiscal year is \$12,000.

Lien Revenue Fees

The Board adopted a \$25 charge for an estoppel letter. Based on the prior years' history of estoppel letters, the estimated amount for this fiscal year is \$9,000.

Delinquent Fees

The District levies a \$25 charge for each month the account is delinquent until the account is current. The projected amount for this fiscal year is \$290,000.

**CORAL SPRINGS IMPROVEMENT DISTRICT “PROPOSED BUDGET 2019/2020”**

REVENUES (Continued)**Contract Utility Billing Services**

The District contracts out utility billing services for the benefit of cost sharing. This fiscal year the District expects to receive \$62,602.

Contract HR & Payroll Services

The District provides human resource and payroll services to other Districts based on fees established under interlocal agreements. Budgeted fees are \$13,289.

Facility Connection Fees

Represents the amount collected for new connections. The amount projected for this Fiscal Year is zero and is based on no new connections.

Meter Fees

Represents the amount collected for meter fees based on the size of the meter. This Fiscal Year the amount projected is zero.

Line Connection Fees

Represents the amount collected for new connections. The amount projected for this Fiscal Year is zero and is based on no new connections.

Interest Income (Restricted)

Interest is earned on restricted bond related accounts and managed by Trust accounts. The District has zero control over performance, and no interest is being budgeted.

Interest Income (Operations)

Interest is earned on cash balances in the District's funds on deposit in checking, money market, and investment accounts. Interest income on these is being budgeted for \$65,000.

**CORAL SPRINGS IMPROVEMENT DISTRICT “PROPOSED BUDGET 2019/2020”**

REVENUES (Continued)**Rent Revenue**

This line item represents the lease of office space to perform work on other Districts. The total revenue from this source is \$65,203.

Technology Sharing Revenue

The District owns an IBM AS-400 computer system as well as a suite of proprietary software programs. Technology sharing is the revenue associated with the performance of duties on the Districts system, phone, fax, ISP and other technology hardware, used for the benefit of the District. The amount being reimbursed by other funds is \$15,450.

Miscellaneous Revenues

Represents miscellaneous fees charged to customers for NSF, meter boxes, repairs and other services provided to customer by the District. Based on prior years' experience, this amount is projected to be \$12,000.

Renewal & Replacement

Funds accumulated in prior years are used in the budget year for payment of various renewal and rehabilitation projects. The amount projected for this Fiscal Year is zero.

**CORAL SPRINGS IMPROVEMENT DISTRICT "PROPOSED BUDGET 2019/2020"**

ADMINISTRATION EXPENDITURES

A contractual increase in independent attorney services, merchant fees, health care insurance and website requirements account mainly for the 4.8% proposed increase in the total administrative budget.

Salaries and Wages

The total amount of budgeted wages for this Fiscal Year is \$1,011,726.

Special Pay

Special pay is a holiday bonus based on the employee's number of years of service. This year's expense is \$2,534.

FICA Taxes

FICA tax is established by law and the current rate is 7.65%. Based on salaries of \$1,011,726 the amount projected for FICA tax is \$77,397.

Pension Expense

The pension plan was established whereby the District makes contributions on behalf of each employee with other funds available to match contributions made by the employee to the deferred compensation plan. Based on salaries of \$1,011,726 the amount projected for pension expense is \$121,408.

Health Insurance

The District offers each employee Health, Life, Dental and Disability Insurance. The amount budgeted is \$233,182.

Worker's Compensation Insurance

The District Worker's Compensation policy is currently with Florida Insurance Alliance. The projected amount for this Fiscal Year is \$3,423.

Unemployment Compensation

Unemployment compensation is expected to be \$4,000.



CORAL SPRINGS IMPROVEMENT DISTRICT “PROPOSED BUDGET 2019/2020”

ADMINISTRATION EXPENDITURES (Continued)

OPEB Expense

Other post-employment benefits (OPEB) are the benefits that an employee will begin to receive at the start of retirement. This does not include pension benefits paid to the retired employee (GASB Statements 74 and 75). The budgeted amount is estimated to be \$2,862.

Engineering Fees

The District currently has a contract with Globaltech, to provide general engineering services not related to or associated with any specific capital improvement project. The contract includes preparation for monthly meetings, monthly reporting, and responses to requests from the Board. Based on anticipated general engineering work the fees are not expected to exceed \$33,600.

Trustee Fees/Other Debt Expense

This expense includes charges associated with the currently existing outstanding bond issues. Pending bond fees & arbitrage costs are not included in this listing.

Trustee Fees (2016 Series)	\$10,120
AMTEC Report	<u>600</u>
Total Expenses	\$10,720

Legal Fees

The District currently has a contract with Lewis, Longman and Walker, PA as legal counsel for the District. This contract includes preparation for monthly board meetings, contract review, etc. In addition, the District expects to have additional expenses with changes to District codification. This year’s budget is not expected to exceed \$60,000.

**CORAL SPRINGS IMPROVEMENT DISTRICT "PROPOSED BUDGET 2019/2020"**

ADMINISTRATION EXPENDITURES (Continued)**Special Consulting Services**

The District may need to engage a consultant that specializes in legislative codification matters that would amend the current charter. Included in those matters are bidding threshold requirements, efficiencies, gains, and benefits inherent in contract administration. Other consulting services may be incurred for special projects as needed. The anticipated cost for all of these services is \$86,000.

Travel & Per Diem (Board)

This expense represents travel expenses for the Board of Supervisor 's. The budgeted amount for this fiscal year is \$4,500.

Annual Audit

The District's auditing firm is Keefe, McCullough & Co., LLP. Based on the current activity level this amount should not exceed \$12,150.

Actuarial Computation - OPEB

Florida state statutes require the employer to make health coverage available to retirees at the employer's group rate. GASB 75 requires a periodic actuarial assessment of the cost and liability associated with these benefits. The budgeted amount for this fiscal year is \$2,700.

Management Fees

This service includes management and financial advisory services provided to the District under the Management Contract with Severn Trent Services. This fiscal year the expense is \$88,552.

Telephone Expense

Telephone Service, fax machine and long-distance calls are included under this expense. Based on the prior years' experience, the amount should not exceed \$13,835.



CORAL SPRINGS IMPROVEMENT DISTRICT “PROPOSED BUDGET 2019/2020”

ADMINISTRATION EXPENDITURES (Continued)

Postage

Overnight deliveries, correspondence, utility bills, etc.

Utility Billing	31,200
Administrative	2,400
Special Mailings	<u>3,000</u>
Total	\$36,600

Printing and Binding

Stationary, utility billing forms, personnel forms, envelopes, photocopies, etc.

Utility Billing	10,000
Administrative	2,970
Accounting	1,300
Annual Water Quality Report	3,500
Personnel Department	1,600
Marketing Materials	<u>2,600</u>
Total	\$21,970

Electric Expense

This expense includes the electric service for the Administrative Building. Based on prior years' expense the projected amount for this Fiscal Year is \$12,960.

CORAL SPRINGS IMPROVEMENT DISTRICT “PROPOSED BUDGET 2019/2020”

ADMINISTRATION EXPENDITURES (Continued)
Rentals and Leases

The following charges are being budgeted in the fiscal year:

Copier Lease	\$ 2,290
Mail Machine	<u>785</u>
Total	\$ 3,075

Insurance

The District retains Egis Insurance & Risk Advisors as our Insurance Agent, who on a yearly basis arranges the placement of the District insurance for property, general liability, and inland marine coverage. The expected amount for this Fiscal Year should not exceed \$16,520.

Repair and Maintenance

The following expenses are anticipated for the budget year.

Pest Control	\$ 1,920
A/C Maintenance & Repairs	13,860
Carpet Cleaning	3,680
Title & Baths Cleaning	700
Building small supplies/materials	1,300
Window Cleaning	1,440
Marble Polishing	1,600
Other Repairs & Maintenance	<u>1,960</u>
Total	\$ 26,460

CORAL SPRINGS IMPROVEMENT DISTRICT “PROPOSED BUDGET 2019/2020”

ADMINISTRATION EXPENDITURES (Continued)
Legal Advertising

The District does most of its legal advertising in the Sun-Sentinel. Expenses include monthly meetings, special meetings, public hearings, request for bids, etc. The estimated amount should not exceed \$4,500.

Other Current Charges

Bank charges and any other miscellaneous expenses that occur during the year as follows:

Meeting Refreshments	\$ 280
Commercial Bank Charges	6,000
Security Signature Stamps	300
Phone System Computer Boards	5,000
Monitoring Fees	775
Employment & Drug Screening	1,800
Other Contractual Services	1,560
Cleaners/Pest Control/etc.	1,200
Miscellaneous Charges	<u>12,995</u>
TOTAL	\$ 29,910

Merchant Fees

The District is charged monthly administrative fees as well as individual transaction fees on all credit card payments we receive. Based on last years' experience the projected amount should not exceed \$78,520.

**CORAL SPRINGS IMPROVEMENT DISTRICT "PROPOSED BUDGET 2019/2020"**

ADMINISTRATION EXPENDITURES (Continued)**Computer/Technology Expenses**

This represents software, anti-virus, web hosting, tech services & additional computer project systems and support for this fiscal year which amount should not exceed \$113,835.

Employment Ads

Recruiting Expenses for qualified candidates for Plant Operators, Field and Administration Personnel. Based on prior years' experience the amount should not exceed \$13,550.

Toilet Rebates

Utility bills are credited \$99 for those customers who install a qualifying toilet under the rebate program established by the District. Budgeted rebates reflect a total of 150 toilets for \$14,850.

Office Supplies

Accounting, Utility Billing and Administrative Supplies such as printer cartridges, file cabinets, computer supplies, file folders, pens, pencils, cleaning supplies, paper products, etc. Based on historical experience the amount should not exceed \$4,000.

Dues, Licenses, Schools & Permits

This item includes professional publications such as GAAP Guide and Florida Statutes. This expense also covers the cost for continuing education requirements and license renewal, management training, and training related to human resources. The amount should not exceed \$12,000.

Promotional Expenses

The District is budgeting \$14,640 for the budget year.



CORAL SPRINGS IMPROVEMENT DISTRICT “PROPOSED BUDGET 2019/2020”

ADMINISTRATION EXPENDITURES (Continued)

Capital Outlay

The budgeted amount of \$23,000 is being provided for the purchase of office carpeting (budgeted but not completed on previous year) and equipment.



CORAL SPRINGS IMPROVEMENT DISTRICT “PROPOSED BUDGET 2019/2020”

EXPENDITURES - PLANT OPERATIONS

Since overall funding remains unchanged from the current fiscal year, a decrease in capital projects compared with previous year is reflected in this section.

An increase in Repairs & Maintenance is due to the electrical upgrades suggested by the Arc Flash study presented by independent Engineers along with generators and wellfield maintenance and repairs.

Salaries and Wages

The total amount of budgeted wages for this Fiscal Year is \$1,700,446.

Special Pay

Special pay is a holiday bonus based on the employee’s number of years of service. This year’s expense is \$2,703.

FICA Taxes

FICA tax is established by law and the current rate is 7.65%. Based on salaries of \$1,700,446 the amount projected for FICA tax is \$130,084.

Pension Expense

The pension plan was established whereby the District makes contributions on behalf of each employee with other funds available to match contributions made by the employee to the deferred compensation plan. Based on salaries of \$1,700,446 the amount projected for pension expense is \$201,000.

Health Insurance

The District offers each employee Health, Life, Dental and Disability Insurance. The amount budgeted is \$354,297.

Worker’s Compensation Insurance

Worker’s compensation insurance is being budgeted for \$93,877.

**CORAL SPRINGS IMPROVEMENT DISTRICT "PROPOSED BUDGET 2019/2020"**

EXPENDITURES - PLANT OPERATIONS (Continued)**OPEB Expense**

Other post-employment benefits (OPEB) calculation budgeted amount is based on previous year calculation and estimated to be \$4,437.

Water Quality Testing

Water Quality Testing is provided by Florida Spectrum Environmental Services, Inc. This Fiscal Year the projected amount for water quality testing is \$68,475.

Telephone Expense

Telephone charges for this Fiscal Year include Bellsouth phone service for Water and Wastewater offices and Sprint phone services. The projected amount for this fiscal year is \$8,900.

Electric Expense

The electric requirements for the plant facility and wells are based upon the operating history. Based on prior year's expense the projected amount for this Fiscal Year is \$698,830.

Rentals and Leases

The District is budgeting \$15,500 for miscellaneous equipment rentals.

Insurance

The District retains Egis Insurance & Risk Advisors as our Insurance Agent, who on a yearly basis arranges the placement of the District insurance for property, general liability, and inland marine coverage. The expense should not exceed \$166,630.

Repairs & Maintenance - General

Repair and maintenance expenses anticipated to be spent in the fiscal year are as follows:



CORAL SPRINGS IMPROVEMENT DISTRICT “PROPOSED BUDGET 2019/2020”

EXPENDITURES - PLANT OPERATIONS (Continued)

Water Department

Flow meters	\$15,000
Sulfuric acid tank cleaning, inspection & repair	60,000
Electrical upgrades	75,000
Interconnect usage	10,000
R&M general	18,000
Air conditioning	6,590
Vehicle maintenance	4,000
Generator maintenance & repairs	23,000
Vibration Analysis Program	41,800
Well & Wellfield Maintenance	164,080
Instrument and Control Repairs/Calibration	56,000
Facility Maintenance	<u>36,700</u>
Total Water	\$ 510,170

CORAL SPRINGS IMPROVEMENT DISTRICT “PROPOSED BUDGET 2019/2020”

EXPENDITURES - PLANT OPERATIONS (Continued)
Wastewater Department

Electrical upgrades	\$120,000
Annual certification	2,500
Sludge Truck Maintenance & Repair	1,900
Air conditioning	10,690
Vehicle Maintenance	2,500
Vibration Analysis Program	9,000
Lift Stations	2,500
Generator Maintenance & Repair	26,675
Deep Well Maintenance	38,000
Instruments & Controls/ Meter Calibration	43,480
Tank Cleaning	55,000
Paint interior Plant C	66,000
Electrical breaker, blower parts & repairs	40,000
Other Facility Maintenance	5,000
Mechanical injection well	<u>500</u>
Total Wastewater	\$ 423,745



CORAL SPRINGS IMPROVEMENT DISTRICT “PROPOSED BUDGET 2019/2020”

EXPENDITURES - PLANT OPERATIONS (Continued)

Maintenance

R&M general	\$6,080
Vehicle Maintenance	3,000
R&M trash pick up	5,720
Lawn Maintenance Contract	52,000
Other Facility Maintenance	<u>7,000</u>
Total Maintenance	\$73,800

TOTAL REPAIRS & MAINTENANCE - PLANT \$1,007,715

Filters for Water Plant

Budgeted replacement costs for filters, membranes and interconnectors for the Water Plant are \$678,290.

Sludge Management - Sewer

Sludge removal costs are budgeted for \$150,000.

Chemicals

Products used in the process of Water & Wastewater treatments. The amount projected to be spent in this fiscal year is \$337,995.

Operating Supplies - General

General operating supplies include laboratory chemicals and miscellaneous tools and equipment. The projected amount is \$98,675.

**CORAL SPRINGS IMPROVEMENT DISTRICT “PROPOSED BUDGET 2019/2020”**

EXPENDITURES - PLANT OPERATIONS (Continued)**Office Supplies**

Paper, pens, folders, and other office supplies. The projected amount for this fiscal year is \$3,635.

Uniforms

Uniform purchases, rentals and safety boot allowances are budgeted at \$9,775.

Motor Fuels

Motor fuels include gasoline and diesel fuel needed for the operation of auxiliary generators. The projected amount is \$99,411.

Dues, Licenses, Schools & Permits

This expense represents costs for license renewals, subscriptions, and employee licensing, books and schooling required to maintain licenses to operate for plant employees. The projected amount for this fiscal year is \$56,950.

Capital Outlay

The District is budgeting amounts for addition of VFD's to wells, post flush recovery reduction, high service pump motor replacement, building drainage improvements, water blower, interconnect study, Plant C repairs and tools for maintenance. The total amount budgeted is \$964,000.

Renewal & Replacement

The District is budgeting \$0 for this concept this fiscal year.

**CORAL SPRINGS IMPROVEMENT DISTRICT "PROPOSED BUDGET 2019/2020"**

EXPENDITURES - FIELD OPERATIONS

Repairs & Maintenance includes upgrades in the Electrical systems. In general, total expenditures decreased due to fewer capital projects.

Salaries and Wages

The total amount of budgeted wages for this fiscal year is \$786,613.

Special Pay

Special pay is a holiday bonus based on the employee's number of years of service. This year's expense is \$1,405.

FICA Taxes

FICA tax is established by law and currently is 7.65%. Based on salaries of \$786,613 the amount projected for FICA tax is \$60,176.

Pension Expense

The pension plan was established whereby the District makes contributions on behalf of each employee with other funds available to match contributions made by the employee to the deferred compensation plan. Based on salaries of \$786,613 the amount projected for pension expense is \$94,394.

Health Insurance

The District offers each employee Health, Life, Dental and Disability Insurance. The amount budgeted is \$247,480.

Worker's Compensation Insurance

The District Worker's Compensation policy is currently with Florida Insurance Alliance. The projected amount is \$49,556.

**CORAL SPRINGS IMPROVEMENT DISTRICT "PROPOSED BUDGET 2019/2020"**

EXPENDITURES - FIELD OPERATIONS (Continued)**OPEB Expense**

Other post-employment benefits (OPEB) calculation budgeted amount is based on previous year calculation and estimated to be \$2,723.

Water Quality Testing

Water Quality Testing is provided by Florida Spectrum Environmental Services, Inc. This Fiscal Year the projected amount for water quality testing is \$1,000.

Naturescape Irrigation Service

Annual fee of \$4,970 is paid to Broward County for the operation of the Naturescape irrigation service.

Telephone Expense

Telephone and fax machine are budgeted annually. Based on prior year's experience the amount should not exceed \$13,950.

Electric Expense

The electric requirements (for Lift Stations) are based upon the operating history. Based on prior years' expense the projected amount for this fiscal year is \$114,480.

Rent Expense

Equipment rental, other than for SCADA, is budgeted for \$9,500.

Rent Expense-SCADA

The District will install and rent components for telemetry lift-station operation and monitoring for \$56,040.



CORAL SPRINGS IMPROVEMENT DISTRICT “PROPOSED BUDGET 2019/2020”

EXPENDITURES - FIELD OPERATIONS (Continued)

Insurance

The District retains Egis Insurance & Risk Advisors as our Insurance Agent, who on a yearly basis arranges the placement of the District insurance for property, general liability, and inland marine coverage. The expected amount for this Fiscal year should not exceed \$24,000.

Repair and Maintenance

Following is a listing of the different repairs and maintenance needed for field operations maintenance.

GIS Services	\$ 37,500
Backhoe maintenance	8,000
Jet machine service	4,000
R&M general	5,000
Electrical upgrades	20,000
Air Conditioning	3,500
Asphalt improvements	30,000
R&M Facilities	4,500
Backflow certifications & replacements	9,500
Valve replacement & maintenance	10,000
Streets & landscape	46,000
Hydrants	18,000
Vehicles	<u>20,000</u>
Total Repairs & Maintenance	\$216,000

**CORAL SPRINGS IMPROVEMENT DISTRICT "PROPOSED BUDGET 2019/2020"**

EXPENDITURES - FIELD OPERATIONS (Continued)**Lift Stations**

This expense is to cover lift stations maintenance and repairs including new pumps and electrical supplies. The District operates 41 Lift Stations on the Field. The projected amount for this fiscal year is \$168,850.

Generators

Amount projected for expenses related to Portable Generators including services and repairs. The District owns 7 Portable Generators. Budget amount should not exceed \$33,080.

Meters

This program was setup to replace old meters. The projected amount for this fiscal year includes new connections and supplies costs. The amount being budgeted for new connections is \$60,680.

Office Supplies

Paper, pens, folders, and other office supplies. The projected amount for this fiscal year is \$1,680.

Operating Supplies

General operating supplies include laboratory chemicals and miscellaneous tools and equipment. The projected amount is \$57,190.

Uniforms

Uniform purchases and rentals and safety boot allowances are budgeted at \$5,820.

Motor Fuels

Motor fuels include gasoline and diesel fuel needed for the operation of portable generators. The projected amount is \$22,860.

**CORAL SPRINGS IMPROVEMENT DISTRICT “PROPOSED BUDGET 2019/2020”**

EXPENDITURES - FIELD OPERATIONS (Continued)**Dues, Licenses, Schools & Permits**

This expense represents the cost for license renewals, subscriptions, and employee licensing, books and schooling required to maintain their license to operate. The projected amount is \$13,300.

Capital Outlay

The District is budgeting for projects such as the purchase of various field related equipment, lift station camera work and rehab of lift stations. The expected amount for this Fiscal year should not exceed \$381,000.

Renewal & Replacement

No amounts are being budgeted for FYE 2019/2020.



CORAL SPRINGS IMPROVEMENT DISTRICT “PROPOSED BUDGET 2019/2020”

DEBT SERVICE

During FY 2015/2016, Coral Springs Improvement District refinanced Series 2007 Bonds with Refunded Revenue Bonds Series 2016 in the amount of \$42,830,000 with a rate of 3.05%.

\$38 million were used to the construction project of water plant and \$4 million has been set aside to take care of interest during the capitalized period, and to ensure those payments are available to the bondholders.

Debt service schedule represents the amount of money required to make payments on the principal and interest on the outstanding loan.

The schedule below reflects principal and interest obligations for the new fiscal year.

**2016 Water and Sewer Refunding Revenue Bonds
DEBT SERVICE SCHEDULE**

Period Ending October 1	Principal Amount	Interest Amount	Total Debt Service
2017	1,075,000	928,935	2,003,935
2018	1,545,000	1,273,528	2,818,528
2019	1,595,000	1,226,405	2,821,405
2020	1,640,000	1,177,758	2,817,758
2021	1,695,000	1,127,738	2,822,738
2022	1,745,000	1,076,040	2,821,040
2023	1,795,000	1,022,817	2,817,817
2024	1,850,000	968,070	2,818,070
2025	1,910,000	911,645	2,821,645
2026	1,965,000	853,390	2,818,390
2027	2,025,000	793,457	2,818,457
2028	2,090,000	731,695	2,821,695
2029	2,150,000	667,950	2,817,950
2030	2,220,000	602,375	2,822,375
2031	17,530,000	534,665	18,064,665
	42,830,000	13,896,468	56,726,468

Ninth Order of Business

ORDERED BY:
ORDERED BY:



Attorney Title Services, LLC
 WWW.ATTORNEY-TITLE-SERVICES.COM
 WWW.ATTORNEY-TITLE-SERVICES.US
 12425 San Jose Blvd, Suite 1
 Jacksonville, Florida 32223
 904.260.0105

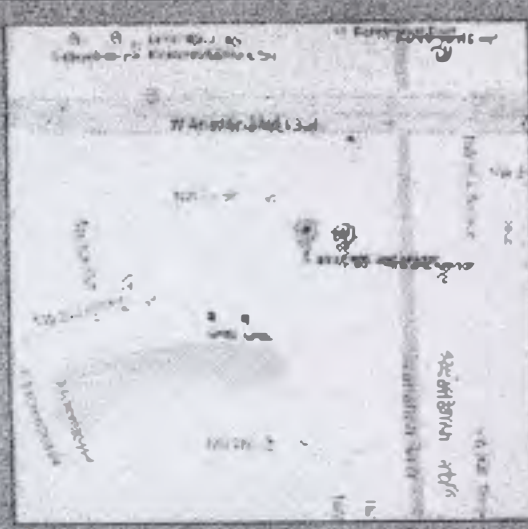

PROPERTY ADDRESS: 8137 NW 2ND MANOR CORAL SPRINGS, FLORIDA 33071
 SURVEY NUMBER: FL16033602

FIELD WORK DATE: 3/28/2016
 REVISION DATE(S): REV 9/22/2016

FL16033602
 BOUNDARY SURVEY
 BROWARD COUNTY

C1
 R = 25' (C.P.M.)
 L = 29' (C.P.M.)
 Δ = 39' (C.P.M.)
 S = 44' (C.P.M.)
 S 44° 26' 06" W 35' 57" (M)
 S 44° 26' 06" W 35' 57" (M)

*287' of 6' high
 wood fence
 1-4' gate
 1-10' DD gates*

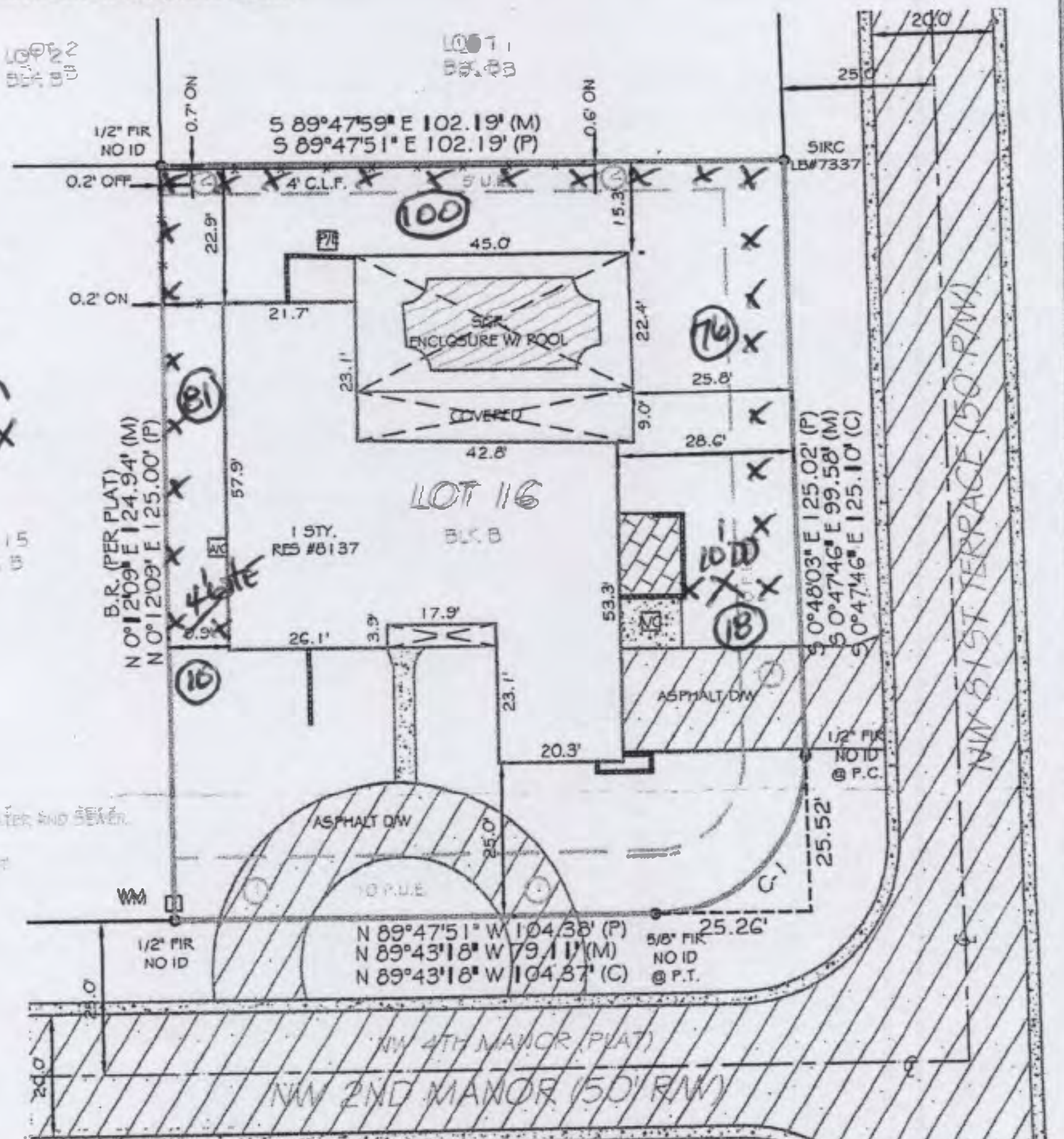

IT APPEARS TO BE SERVED BY CITY WATER AND SEWER.
 PRICE OWNERSHIP NOT DETERMINED
 D.U.E. = DRAINAGE AND UTILITY EASEMENT
 P.U.E. = PUBLIC UTILITY EASEMENT

I hereby certify that this boundary survey of the hereon described property has been made under my direction and to the best of my knowledge and belief, it is a true and accurate representation of a survey that meets the standards of practice set forth by the Florida Board of Professional Surveyors & Mappers in Chapter 58-177 of the Florida Administrative Code.

RONALD W. WALLING
 State of Florida Professional Surveyor and Mapper
 License No. 6493

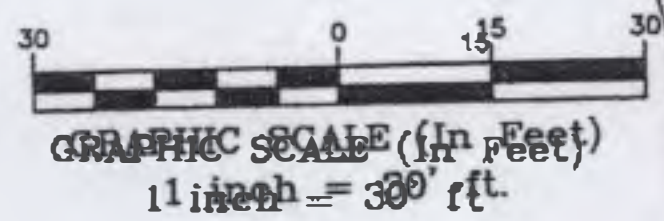

Use of This Survey for Purposes other than intended without the Surveyor's consent is prohibited. The Surveyor assumes no liability for the use of this survey for purposes other than intended without the Surveyor's consent.

FLOOD INFORMATION:
 BY PERFORMING A SEARCH WITH THE LOCAL GOVERNING MUNICIPALITY OR WWW.FEMA.GOV, THE PROPERTY APPEAR TO BE LOCATED IN A FLOOD SHADDED AREA. THIS PROPERTY WAS FOUND IN THE CITY OF CORAL SPRINGS, COMMUNITY NUMBER 12033, DATED 08/18/14.

CLIENT NUMBER: 16A-85-60085
 DATE: 3/28/2016

BUYER: JUAN C. ALONSO
 BUYER: JUAN C. ALONSO

SELLER: THE BANK OF NEW YORK MELLON
 SELLER: THE BANK OF NEW YORK MELLON

CERTIFIED TO: JUAN C. ALONSO, ATTORNEY AT LAW, FIRM OF LEGAL COUNSEL, CHICAGO, ILLINOIS
 CERTIFIED TO: JUAN C. ALONSO, ATTORNEY AT LAW, FIRM OF LEGAL COUNSEL, CHICAGO, ILLINOIS
 SUGGESTIONS AND/OR ASSIGN AS THEIR INTERESTS MAY APPEAR

This is page 1 of 2 and is not valid without the other pages.

CONDITIONS OF INTEREST
 A BURNAL DEED GRANTING OVER TO PUBLIC UTILITY EASEMENT 2.4'
 CHAIN LINK FENCE OVER 5' UTILITY EASEMENT 2.2'

Ramon Rivera

C: 994.488.88093
 00994.550.88080
 RRivera@live.com



EXACTA
 and Surveyors, Inc.

11940 Fairway Lakes Drive, Suite 101, Ft. Myers, FL 33913
 11940 Fairway Lakes Drive, Suite 101, Ft. Myers, FL 33913

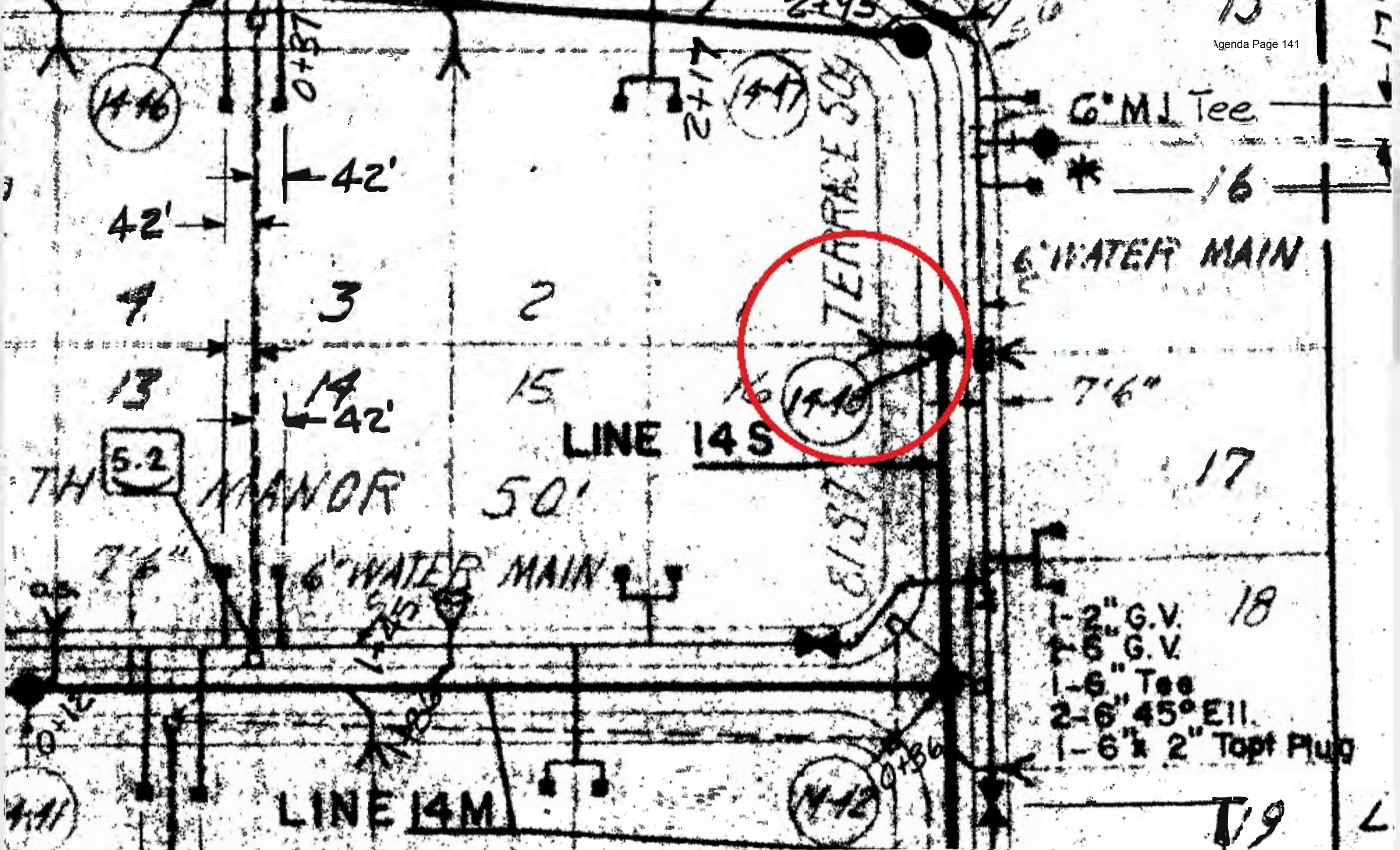

446

0+87

2+17

447

6" M.I Tee

42'

* 1/6

6" WATER MAIN

3

2



7'6"

13

42'

15

16

1740

LINE 14S

TH 5.2

MANOR

50'

61517

6" WATER MAIN

- 1-2" G.V. 18
- 1-6" G.V.
- 1-6" Tee
- 2-6" 45° Ell.
- 1-6" 2" Topf Plug

LINE 14M

448

0+86

19

E-1
 R# 2500 (RAM)
 L# 30 71 (P) 30 57 (M)
 S# 31 100 (P) 30 51 (M) 30 59 (M)
 S# 44 42 (P) W. 35 66 (P)
 S# 44 20 (P) W. 35 57 (M)

287' of 6' high
 vertical shadowbox
 wood fence
 1-4' gate
 1-10' DD gates

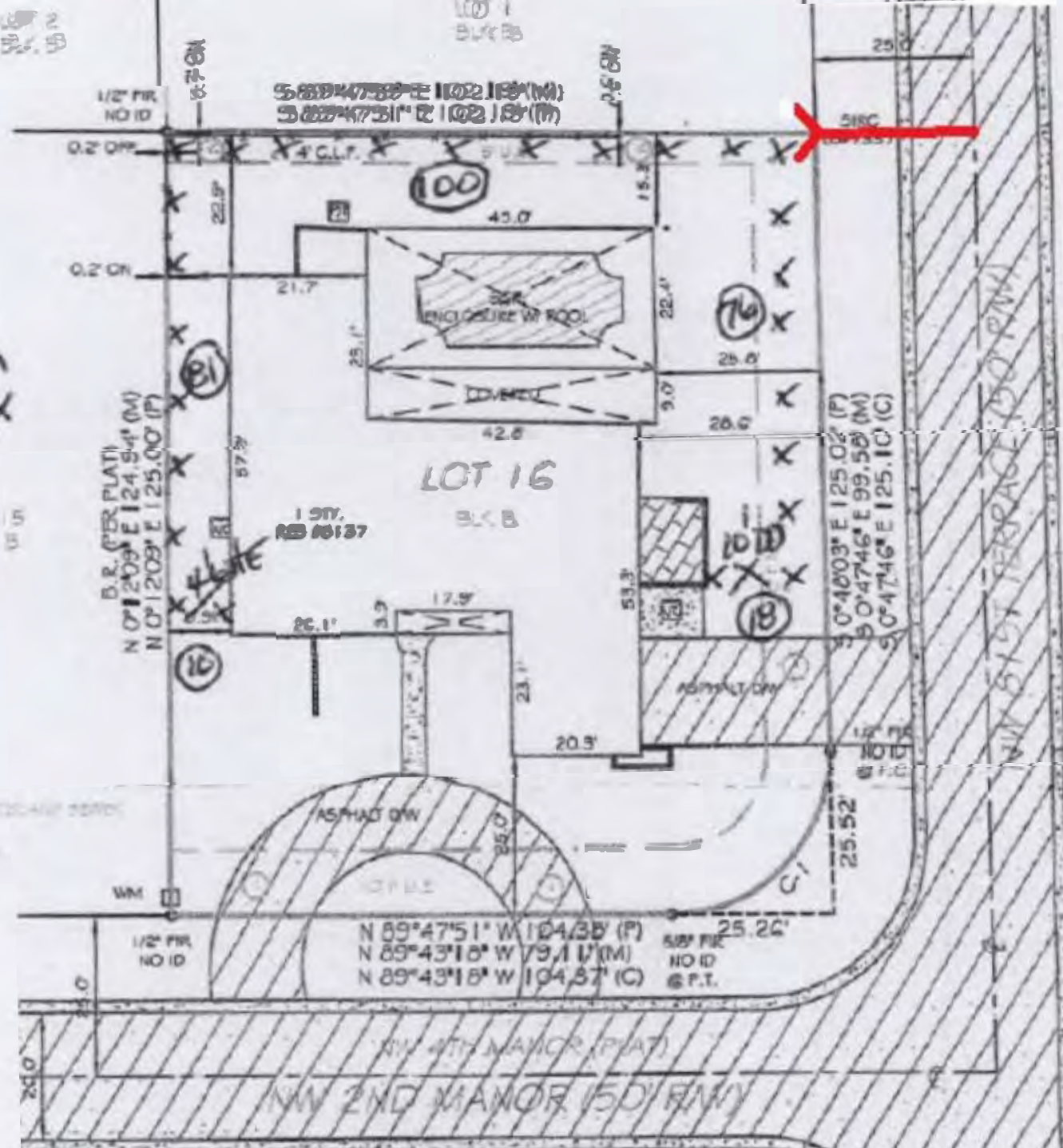

I hereby certify that the boundary survey of the hereon described property has been made under my direction, and to the best of my knowledge and belief, it is a true and accurate representation of a survey that meets the Standards of Practice of a Professional Surveyor.



Tenth Order of Business

10A.

July 1, 2019

Mr. David McIntosh
Director of Utilities
Coral Springs Improvement District
10300 NW 11th Manor
Coral Springs, FL 33071

Dear Mr. McIntosh

Subject: Automatic Transfer Switch Evaluation and Installation

On June 20, 2019, the Coral Springs Improvement District (CSID) water treatment plant (WTP) operating staff observed a functional failure of the automatic transfer switch (ATS) providing power to the water treatment portion of your facility. The ATS is a mechanism that automatically engages the backup emergency generator during a power failure. The switch failed in such a manner that power could potentially be fed to the high service pump (HSP) building simultaneously through both network (FPL) power and the emergency backup generator which posed a significant safety hazard. As a result, the circuit leading to the HSP Building from the emergency generator was isolated. This temporary modification, has left the HSP building without power in the event of electrical service disruption.

Globaltech was called upon to assist CSID with assessing the failure of the ATS. Our electrical engineering staff assisted with assessing the electrical failure and developing alternatives to returning the system to full operation. The ATS was determined to be approximately 30 years old and was determined to be unrepairable. It was therefore determined that the facility should move forward with acquiring and installing an entirely new ATS.

Under the declaration of a utility emergency and staff direction, Globaltech has begun with the acquisition of a new ATS. We have already prepared a purchase order for the system and have worked with the supplier to meet an accelerated delivery deadline. It is anticipated that the system will be delivered within four weeks and fully operational within two weeks of delivery (August 9, 2019).

The purpose of this letter is to inform you that Globaltech is acting upon your request and has begun to incur expenses for this activity. In summary, we anticipate that the following expenses will be incurred during the assessment, procurement and installation of the new ATS:

- Engineering Assessment and Equipment Procurement - \$10,000
- ATS and Utility Disconnect Purchase - \$59,000



-
- Electrical Installation of ATS, temporary power, and mods to exist equip - \$68,000
 - Installation of Temporary Generators for High Service Building during ATS installation - \$10,000, excluding fuel.

The anticipated total for these services is estimated not to exceed \$147,000.

Under your direction, we are working without a formal authorization to meet the time requirements and criticality of this endeavor. Upon completion of this activity, we will meet with you to review our expenses and settle upon an equitable fee.

We appreciate your trust and confidence in Globaltech and will do everything within our capability to assist CSID during this period of emergency.

Please call me if you have any questions.

Regards,



Rick Olson, P.E.
Director of Client Services

Cc: Ken Cassel / Inframark
Dan Daly / CSID
Paul Gandy / Globaltech
Dave Schuman / Globaltech

10B.

July 1, 2019

Mr. David McIntosh
Director of Utilities
Coral Springs Improvement District
10300 NW 11th Manor
Coral Springs, FL 33071

Dear Mr. McIntosh

Subject: Emergency Installation of High Service Pumping System

On June 20, 2019, the Coral Springs Improvement District (CSID) water treatment plant (WTP) operating staff observed a functional failure of the automatic transfer switch (ATS) providing power to the water treatment portion of your facility. The ATS is a mechanism that automatically engages the backup emergency generator during a power failure. The switch failed in such a manner that power could potentially be fed to the high service pump (HSP) building simultaneously through both network power (FPL) and the emergency backup generator which posed a significant safety hazard. As a result, the circuit leading to the HSP Building from the emergency generator was isolated. This temporary modification, has left the HSP building without power in the event of an electrical service disruption.

To provide for temporary service in the result of an FPL power interruption, CSID has requested that Globaltech install a temporary pumping system to distribute water from the WTP to CSID's water customers. The system generally consists of a stud mounted 175 HP diesel engine, centrifugal pump capable of 1,500 - 4000 gpm, fuel storage and miscellaneous piping connections. The temporary pump will be set up to come on automatically if a drop below 50 psi is observed in the distribution system.

Under the declaration of a utility emergency and staff direction, Globaltech has begun with the acquisition and installation of the temporary pumping system. It is anticipated that the system will be fully operational by Wednesday, July 3, 2019, and will be available until a new ATS has been installed (approximately 5 weeks).

The purpose of this letter is to inform you that Globaltech is acting upon your request and has begun to incur expenses for this activity. In summary, we anticipate that the following expenses will be incurred during the installation, rental, operation, and removal of the pumping system:

- Engineering - \$10,000
- Equipment Installation - \$15,000



-
- Pump Rental (approximately 5 weeks) - \$15,000
 - Periodic Operational checks and maintenance - \$6,000
 - Equipment Removal and site restoration - \$10,000

The anticipated total for the temporary pump installation is estimated not to exceed \$56,000. Should the replacement of the ATS take longer than expected, additional rental fees would be incurred. In addition, providing and fueling the diesel engine associated with the temporary pumping system will be the responsibility of CSID.

Under your direction, we are working without a formal authorization to meet the time requirements and criticality of this endeavor. Upon completion of this activity, we will meet with you to review our expenses and settle upon an equitable fee.

We appreciate your trust and confidence in Globaltech and will do everything within our capability to assist CSID during this period of emergency.

Please call me if you have any questions.

Regards,

A handwritten signature in blue ink that reads "Rick Olson".

Rick Olson, P.E.
Director of Client Services

Cc: Ken Cassel / Inframark
Dan Daly / CSID
Paul Gandy / Globaltech
David Schuman / Globaltech

Eleventh Order of Business

11A.

AMENDMENT 1
To WORK AUTHORIZATION-149

No. GT-151107

Pursuant to the provisions contained in the "Contract for Professional Engineering Consulting and Design-Build Services on a Continuing Contract Basis " between the CORAL SPRINGS IMPROVEMENT DISTRICT, hereinafter referred to as "OWNER", and Globaltech, Inc., hereinafter referred to as "FIRM", dated July 1, 2012 (hereinafter referred to as "AGREEMENT"), this Work Authorization, executed this ____ day of _____ 2018, authorizes the FIRM to provide services under the terms and conditions set forth herein and in the AGREEMENT, which is incorporated herein by reference as though set forth in full.

The OWNER desires design-build services related to High Service Pump Building Valve Replacement, hereinafter referred to as the "Specific Project".

Section 1 – Terms

The FIRM shall be defined as an individual, corporation or contractor having a direct contract with the OWNER or with any other subcontractor in the performance of a part of the work contracted for under the terms of this Work Authorization with the OWNER.

Section 2 – Scope of Work

Work Authorization 149 was approved by the OWNER on October 15, 2018. In summary, the work authorization was prepared to replace five (5) valves on the north side of the high service pump building and to abandon 2-16-inch ductile iron pipes that were no longer in use. Work had previously been done by OWNER and FIRM that indicated the valves in question (2 – 24-inch butterfly valves, 2 – 16-inch butterfly valves and 1- 6-inch gate valve) could not be used to isolate portions of the treatment system and should be replaced. It was subsequently determined

that the 6-inch gate valve did not need to be replaced and a credit for this work is issued in this amendment.

A plan was developed to replace the valves while minimizing plant interference. The plan was prepared so that all work could be performed during the course of a one-day shut down. During the shutdown, the Utility would go on emergency interconnections and suspend water treatment operations. Upon completing the valve installation, it was proposed to treat the project as a line break / maintenance activity; the plant would be returned to service and bacteriological samples would be collected.

Prior to conducting work, FIRM notified the Florida Department of Environmental Protection (FDEP) of the proposed maintenance activity. FDEP immediately responded that the proposed activity would require a precautionary boil water notice order to be issued to the entire service area. This notification was deemed to be unacceptable by OWNER and FIRM was directed to develop an alternative approach.

FIRM immediately looked for alternative methods which would allow a partial plant shut down to keep the distribution system pressurized. A plan was developed that permitted a portion of the high service pumping system to remain in service while the defective valves were replaced. This revised plan resulted in the need to perform the valve replacement in two steps requiring two mobilizations by FIRM, two separate line-stop installations (by Rangeline), and the installation of several sample taps to sample small segments of the distribution line before they were returned to service. The modified plan resulted in additional charges by FIRM, however, precluded the need for a boil water notice. This Amendment 1 to Work Authorization 149 request reimbursement for the additional charges incurred during the implementation of the revised plan.

Task 1 – Project Coordination/Review

No changes.

Task 2 – Engineering and Project Management

During the development of the revised installation plan, significant engineering time was devoted to developing a procedure that would permit a localized shut down while replacing the defective valves. No additional funding is necessary; however, FIRM requests access to the allowance (\$2,500) originally provided in WA-149 to fund this effort.

Task 3 – Construction of Improvements

The following summary describes the additional work activities performed by FIRM:

- The original cost estimate on this project was based on Phase 1 & Phase 2 work in one mobilization with the plant discontinuing water production during maintenance activities. To avoid a precautionary boil water notice to the customers, the tie-in procedure had to be changed. Work was conducted in two steps while a portion of the distribution system remained in service. This resulted in two mobilizations by FIRM, subcontractors, and additional work.
- Pump shut down & tie-in for the Phase 2 was carried out several weeks after Phase 1. This resulted FIRM demobilizing equipment after Phase 1 and remobilizing for Phase 2. The work was carried with two different mobilizations in lieu of one mobilization as planned in the original estimate.
- Line stop installation subcontractor (Rangeline, Inc.) installed an additional 24" tapping saddle and tested for the anticipated isolation

requirement for the Phase 2. The material has removed by Range line Inc. from the line and turned over OWNER. This task resulted in added value for the OWNER as additional "operation flexibility" is now build into the distribution system.

- A 24-inch split type restraint was added on the line that is close to the existing 24" tee-junction. This restraint was installed to avoid damage to the existing line while Rangeline installed the line stop tapping. If the joint had failed during this operation, the distribution system would have immediately lost pressure and the system would have been down for several week.
- Additional sample ports were required to implement the new plan so that small segments of the distribution system could be worked on, sampled, cleared and returned to service. Additional corp stops, sample taps and above ground pads were purchased and installed.
- Additional 16" plugs, mega lugs and flange kits were required based on the new plan. The additional material was purchased and installed.
- Additional excavation and backfilling were required to locate the existing restraints, to install the additional 24" line stop, and to install the plugs on the 16-inch lines. In addition, some areas of the excavated areas of the Phase 1 work had been filled backfilled (for the campus open house) and had to be re-excavated.
- During the execution of this project, it was determined that the 6-inch gate valve did not need to be replaced. A credit (\$1e760) for the valve, appurtenances, and labor to install the valve is provided with this amendment.

Assumptions

No changes

Section 3 – Location

No changes

Section 4 – Deliverables

No changes

Section 5 - Time of Performance

No changes – work was completed in April 2018

Section 6 - Method and Amount of Compensation

1. The FIRM shall be paid by the OWNER in accordance with the Florida's Prompt Payment Act Florida Statute 218.70-79 and in accordance with the payment method as set forth in Section 6 of the AGREEMENT. The calculations shall begin using the date the invoice was received.
2. **This Amendment 1 is for \$34,568** (original work authorization budget \$129,747). **Revised work authorization budget is \$164,315.**
3. On the terms contained in the FIRM's said proposal for the doing of said work and the said award therefore, and the specifications herein specifically referred to and made a part of this contract.
4. The cost for the above scope of services is a Lump Sum Price (LSP). The LSP is based on the materials, methods, and assumptions presented in the scope of services and may be adjusted downward based on final detail design and alternative selections or omissions. The LSP shall not be greater than the stated amount unless there is an approved increase in the scope of services. The final stipulated sum (adjusted LSP) submitted herein shall be an amount to be billed on the basis of "percent complete" and stored materials turned over to the OWNER.
5. Budget Summary for Amendment 1 for the above lump sum fee is provided in **Attachment A.**

Section 7 – Application for Progress Payment

1. Unless otherwise prescribed by law, at the end of each month, the FIRM shall submit to the OWNER for review, an Application for Progress Payment filled out and signed by the FIRM covering the Work completed as of the date of the Application and accompanied by such supporting documentation as is required by the AGREEMENT.
2. The Application for Progress Payment shall identify the amount of the FIRM Total Earnings to Date based upon value of original contract Work performed to date as approved by fully executed Change Orders.
3. Payment shall be based upon percentage of work completed based upon the approved schedule of values. Retainage in the amount of 10% will be withheld on the calculated value of any work, with the exception of stored materials which may be paid at the supplier's invoiced cost. At FIRM's request, after 50% completion of the work has been achieved, the OWNER will implement a reduction in retainage to 5% of all future pay requests. If retainage is reduced, FIRM may not withhold more than 5% retainage from subcontractors or suppliers and will be required to certify compliance with F.S. 218.270 *et seq* on each subsequent pay application. Notwithstanding the foregoing, in no instance can the amount retained be less than the value of OWNER's good faith claims plus the value of the work the OWNER determines remains to be put in place or required to be performed as remedial activities. For the purposes of this section, 50% completion shall be that point in time when OWNER determines that half of the Work required by the Contract has been completed. In no event shall the Work be determined to be 50% completed before the OWNER has paid 50% of the Contract amount and 50% of the Contract time has expired. The amount of previous Pay Estimate payments shall then be subtracted to equal the Balance Due during the Pay Estimate period.
4. When the OWNER determines the Work to be Substantially Complete, the OWNER may reduce the retainage to five percent (5%) of the dollar value of all Work satisfactorily completed to date, provided that the FIRM is

making satisfactory progress toward Final Completion of the Work, that in the opinion of the OWNER there is no specific cause for a greater retainage, and the FIRM obtains the written consent of the Surety Companies furnishing the required Public Construction Bond on consent forms provided by the OWNER. The OWNER may reinstate the retainage up to ten percent (10%) if the OWNER determines, that the FIRM is not making satisfactory progress toward final completion of the Work or where there is other specific cause for such withholding.

5. Partial payment may be made for the delivered cost of stored materials planned for incorporation into the Work, provided such materials meet the requirements of this Contract, the Contract Drawings, and the Specifications, and are delivered and suitably stored at the project site, or at another location acceptable to the OWNER. Such material must be stored in a secure manor acceptable to the OWNER, and in accordance with the manufacturer's recommendations.
6. The delivered cost of such stored or stockpiled materials may be included in any subsequent application for payment provided the FIRM meets the following conditions:
 - a. An applicable purchase order or supplier's invoice is provided listing the materials in detail, the cost of each item, and identifies this specific contract by name.
 - b. The materials are fully insured against loss or damage (from whatever source) or disappearance prior to incorporation into the Work.
 - c. Stored materials approved for payment by the OWNER shall not be removed from the designated storage area except for incorporation into the Work.
 - d. Evidence that the FIRM has verified quantity and quality of the materials delivered (verified packing list).
7. It is further agreed between the parties that the transfer of title and the OWNER's payment for any stored or stockpiled materials pursuant to these

General Conditions, and any applicable provisions of the Supplementary General Conditions, shall in no way relieve the FIRM of the responsibility of ensuring the correctness of those materials and for furnishing and placing such materials in accordance with the requirements of this Contract, the Contract Drawings, the Technical Specifications, and any approved changes thereto.

8. The following monthly Application for Progress Payment shall be accompanied by Bills of Sale, copies of paid invoices, releases of lien, or other documentation warranting that the FIRM has received the stored materials and equipment free and clear of all liens, charges, security interests, and encumbrances (which are hereinafter in these General Conditions referred to as "Liens") and evidence that the stored materials and equipment are covered by appropriate property insurance and other arrangements to protect the OWNER's interest therein, all of which shall be satisfactory to the OWNER.
9. The FIRM shall warrant and guarantee that title to all Work, materials, and equipment covered by an Application for Progress Payment, whether incorporated in the Work or not, will pass to the OWNER no later than the time of Final Payment free and clear of all liens or other encumbrances.
10. In the event any dispute with respect to any payment or pay request cannot be resolved between the FIRM and OWNER's project staff, FIRM may, in accordance with the alternative dispute resolution requirements of Florida Statute section 218.72, *et seq*, demand in writing a meeting with and review by the OWNER'S (agency) director. In the absence of the agency director, a deputy director may conduct the meeting and review. Such meeting and review shall occur within ten (10) business days of receipt by OWNER of FIRM's written demand. The OWNER's manager shall issue a written decision on the dispute within ten (10) business days of such meeting. This decision shall be deemed the OWNER's final decision for the purposes of the Local Government Prompt Payment Act.

Section 8 – Responsibilities

The FIRM shall, under no circumstance, look to the OWNER to provide any labor or equipment for the FIRM. The FIRM and its Subcontractors shall provide all of the labor and equipment necessary to perform the job or services contracted for at the expense of the FIRM. Property of any kind that may be on the premises, which are the site of the performance of this contract, during the performance of this Work Authorization, shall be at the sole risk of the FIRM.

- 8.1** The OWNER hereby designates Joe Stephens as the OWNER's representative.
- 8.2** In addition to applicable provisions of Section 2 of the AGREEMENT, the OWNER will:
- Provide access to potable water

The FIRM acknowledges and understands that it is an independent contractor in its relationship with the OWNER. The FIRM hereby designates Rick Olson, P.E. as the FIRM's representative.

Section 9 – Insurance

The FIRM shall provide certificate of insurance to the OWNER setting forth the type and amount of insurance carried by the FIRM and conforming to the minimum requirements set forth in the AGREEMENT.

Section 10 – Level of Service

The OWNER shall have the right to terminate said Agreement by giving the FIRM thirty (30) days written notice if the service that is being provided is not maintained at levels necessary to provide the required service. The OWNER will determine in its sole judgment what constitutes a satisfactory level of service.

Section 11 – Indemnification

The Firm shall indemnify and hold harmless the Owner and its officers and employees as set forth in Section 11 of the Agreement.

IN WITNESS WHEREOF, this Work Authorization, consisting of ten (10) pages and Attachment A has been caused fully executed on behalf of the FIRM by its duly authorized officer, and the OWNER has the same to be duly name and in its behalf, effective as of the date herein above written.

(SEAL)

CORAL SPRINGS IMPROVEMENT DISTRICT

ATTEST:

President

Printed name of Witness

Printed name

Printed name of Witness

Date

Approved as to form and legality

Printed name of Witness

District Counsel

Printed name of Witness

State of Florida
County of Palm Beach

ENGINEER

Globaltech Inc.
Company

The foregoing instrument was acknowledged before me on this

 day of , 2019by

Signature

who is personally known to me OR produced _____ as identification.

Troy L. Lyn, Vice President

Name and title (typed or printed)

Signature of Notary

August 19, 2019
Date

Attachment A

Budget Summary



Takeoff Worksheet

08/02/19

**Coral Springs Improvement Dist
151107 CSID HSP Building Valve Replacement**

Assembly#	Part#	Description	Unit	Quantity	Ext. Price
Job: 151107 CSID HSP Building Valve Replacement					
	Bid Item:	200 Change Order			
		Credit			
		6 Inch MJ BFV, Flange Kits & Accessories	LOT	-1.00	-1,002.86
		4-Man Crew	CR-D	-0.50	-757.54
		Adder			
		24" Linestop (Tapping Saddle Handed Over to CSID)	LOT	1.00	10,502.32
		24" Split type Restraint, TS, CS, Cap & Plug	LOT	1.00	9,228.75
		Flange Kits & Misc Materials	LOT	1.00	1,845.75
		4-Man Crew	CR-D	6.00	9,090.45
		Purchasing & Subcontracts	HR	8.00	1,064.85
		Office Admin	HR	6.00	519.86
		Construction PM	HR	12.00	1,492.78
		Backhoe w/ forks	WEEK	1.00	1,476.60
		Plate Compactor reversible 7000-8000lb	Week	1.00	676.78
		Pick Up & Delivery Charge	EA	1.00	430.26
				Bid Item Totals:	34,568.00
				Grand Totals:	34,568.00

11B.

AMENDMENT 1 TO
WORK AUTHORIZATION 152

Globaltech No. 151116

Pursuant to the provisions contained in the "Contract for Professional Engineering Consulting and Design-Build Services on a Continuing Contract Basis " between the CORAL SPRINGS IMPROVEMENT DISTRICT, hereinafter referred to as "OWNER", and Globaltech, Inc., hereinafter referred to as "FIRM", dated July 1, 2012 (hereinafter referred to as "AGREEMENT"), this Work Authorization authorizes the FIRM to provide services under the terms and conditions set forth herein and in the AGREEMENT, which is incorporated herein by reference as though set forth in full.

The OWNER desires design-build services related to the Membrane Plant ORP Analyzer, hereinafter referred to as the "Specific Project".

Section 1 – Terms

NO CHANGE.

Section 2 – Scope of Work

Amendment 1 is reimbursing funds for unspent allowance of \$2,000.00.

Section 3 – Location

NO CHANGE.

Section 4 – Deliverables

NO CHANGE.

Section 5 – Time of Performance

NO CHANGE.

Section 6 – Method and Amount of Compensation

This Amendment No. 1 to Work Authorization 152 decreases the \$45,347.00 contract value by \$-2,000.00, to a new final contract amount of \$43,347.00.

Section 7 – Application for Progress Payment

NO CHANGE.

Section 8 – Responsibilities

NO CHANGE.

Section 9 – Insurance

NO CHANGE.

Section 10 – Level of Service

NO CHANGE.

Section 11 – Indemnification

NO CHANGE.

IN WITNESS WHEREOF, this Amendment to a Work Authorization, consisting of three (3) pages has been caused fully executed on behalf of the FIRM by its duly authorized officer, and the OWNER has the same to be duly name and in its behalf, effective as of the date herein above written.

CORAL SPRINGS IMPROVEMENT DISTRICT

Signature of Witness

Signature of President

Printed name of Witness

Printed Name of President

Date
Approved as to form and legality

State of Florida
County of Palm Beach

District Counsel
FIRM

Globaltech, Inc.
Company

The foregoing instrument was
acknowledged before me on this

____ day of July, 2019 by

Signature
Troy L. Lyn, P.E., Executive Vice President
Name and Title (typed or printed)

Troy L. Lyn, P.E.
who is personally known to me OR
produced _____ as identification.

July , 2019
Date

Signature of Notary

11C

WORK AUTHORIZATION

CSID WA No. 162

Globaltech No. 151175

Pursuant to the provisions contained in the "Contract for Professional Engineering Consulting and Design-Build Services on a Continuing Contract Basis " between the CORAL SPRINGS IMPROVEMENT DISTRICT, hereinafter referred to as "OWNER", and Globaltech, Inc., hereinafter referred to as "FIRM", dated July 1, 2012 (hereinafter referred to as "AGREEMENT"), this Work Authorization authorizes the FIRM to provide services under the terms and conditions set forth herein and in the AGREEMENT, which is incorporated herein by reference as though set forth in full.

The OWNER desires design-build services related to the CSID WTP Well No. 9 Control Panel Replacement, hereinafter referred to as the "Specific Project".

Section 1 – Terms

FIRM shall be defined as an individual, corporation or contractor having a direct contract with the OWNER or with any other subcontractor in the performance of a part of the work contracted for under the terms of this Work Authorization with the OWNER.

Section 2 – Scope of Work

The OWNER desires to replace the existing well motor control at Raw Water Well No. 9 with a new control panel complete with variable frequency drive (VFD). The new control panel will be built to UL standards, come with complete schematic drawings, and allow future integrators and contractors to identify and make panel modifications with proper documentation.

The new VFD will allow CSID staff to control a range of flows coming out of the well, allowing for a variable level of production. The existing motor control is an across the line contactor style starter.

The existing control panel is inadequately sized and unequipped to handle the added heat gain from the new VFD, and the panel has been modified/retrofitted to the point that it could be considered unsafe to work on. Replacing the existing well motor control panel will eliminate these safety hazards.

The new well control panel will be equipped with a heat exchanger and sun shielding, be painted white, and be appropriately sized to house the new VFD. A new PLC and I/O modules will be included to permit control of the VFD. Plant SCADA and PLC updates will be made to give CSID staff remote access and control and the local PLC will be, likewise, programmed with logic for control and status.

Task 1 – Engineering Services

This task includes project management and engineering services required to complete the project.

Engineering and Project Management

1. Attend preliminary scoping meetings with the OWNER to assist in preliminary design parameters and overall scope.
2. Meet with the OWNER, to discuss the preliminary design review comments.
3. Prepare detailed construction schedule to include as a minimum; design, site mobilization, detailed construction activities, scheduled shut downs and durations, equipment/material delivery times, testing, and startup and commissioning.
4. Coordinate material and equipment purchase and subcontractors.
5. Review, administer, and track equipment submittals.
6. Schedule and conduct meetings, inspections, and testing with OWNER's staff.
7. Attend progress meetings and coordination meetings
8. Oversee construction activities enforcing the conditions of the design.

9. Conduct Substantial Completion inspection. Develop punch-list items in association with OWNER.
10. Conduct Final Completion inspection meeting and site walk through with OWNER.

Task 2 – Construction Services

This task entails installing a new motor control unit and cabinet at Raw Water Production Well No. 9. The work, in general consists of the following:

1. Furnish and install new 60hp rated VFD control panel and new conduit and wiring to existing RTU panel.
2. Extend existing fencing as required to enclose new VFD control panel.
3. Terminate all required wiring.
4. Modify existing well PLC with required I/O modules and logic to control and monitor new VFD
5. Furnish and install conduit and wiring as required.
6. Furnish and install new SS pump terminal junction box.

Assumptions

Assumptions for the project are as follows:

- No lighting modifications are included.
- No DEP permits are required
- No Building Department permits are required
- Working hours will be Monday through Friday from approximately 8:00 AM until 5:00 PM.
- The existing Plant PLC and SCADA to control and monitor new VFD will be modified by others contracted by FIRM.
- No design drawings are included.
- Tree/vegetation trimming in front of proposed new VFD panel location (if needed) shall be performed by CSID.
- OWNER will store panel within WTP following offloading by FIRM.

Section 3 – Location

The services to be performed by the FIRM shall be at the Raw Water Well No.9.

Section 4 – Deliverables

The FIRM will provide the following Deliverables to OWNER:

- Submittals for materials/equipment.
- Construction Improvements
- O&M manuals for the equipment of Improvements

Section 5 – Time of Performance

Project will commence after execution of this Work Authorization and a Notice to Proceed is issued by OWNER. The FIRM and OWNER agree to the following schedule:

Task	Time Elapsed to Completion
Notice to Proceed (NTP)	0 Days
Final Design	45 Days after NTP
Procurement	165 Days after NTP
Construction of Improvements	195 Days after NTP
Close out	215 Days after NTP

Section 6 – Method and Amount of Compensation

1. The FIRM shall be paid by the OWNER in accordance with the Florida’s Prompt Payment Act Florida Statute 218.70-79 and in accordance with the payment method as set forth in Section 6 of the AGREEMENT. The calculations shall begin using the date the invoice was received.
2. Total job price: **\$96,999.00.**
3. On the terms contained in the FIRM’s said proposal for the doing of said work and the said award therefore, and the specifications herein specifically referred to and made a part of this contract.
4. The cost for the above scope of services is a lump sum (LS). The LS is based on the materials, methods, and assumptions presented in the scope

- of services and may be adjusted based on final detail design and alternative selections or omissions. The LS shall not be greater than the stated amount unless there is an approved increase in the scope of services.
5. An allowance of \$2,000 is included in the total fee. The allowance will not be accessed without approval by OWNER. Unused allowance will be returned at the completion of the project.
 6. A Budget Summary for the above LS is provided in Attachment A.

Section 7 – Application for Progress Payment

1. Unless otherwise prescribed by law, at the end of each month, the FIRM shall submit to the OWNER for review, an Application for Progress Payment filled out and signed by the FIRM covering the Work completed as of the date of the Application and accompanied by such supporting documentation as is required by the AGREEMENT.
2. The Application for Progress Payment shall identify the amount of the FIRM Total Earnings to Date based upon value of original contract Work performed to date as approved by fully executed Change Orders.
3. Payment shall be based upon percentage of work completed based upon the approved schedule of values. Retainage in the amount of 10% will be withheld on the calculated value of any work, with the exception of stored materials which may be paid at the supplier's invoiced cost. At FIRM's request, after 50% completion of the work has been achieved, the OWNER will implement a reduction in retainage to 5% of all future pay requests. If retainage is reduced, FIRM may not withhold more than 5% retainage from subcontractors or suppliers and will be required to certify compliance with F.S. 218.70 *et seq* on each subsequent pay application. Notwithstanding the foregoing, in no instance can the amount retained be less than the value of OWNER's good faith claims plus the value of the work the OWNER determines remains to be put in place or required to be performed as remedial activities. For the purposes of this section, 50% completion shall be that point in time when OWNER determines that half of the Work required by the Contract has been completed. In no event shall the Work

- be determined to be 50% completed before the OWNER has paid 50% of the Contract amount and 50% of the Contract time has expired. The amount of previous Pay Estimate payments shall then be subtracted to equal the Balance Due during the Pay Estimate period.
4. When the OWNER reduces the retainage to five percent (5%), FIRM must obtain the written consent of the Surety Companies furnishing the required Public Construction Bond on consent forms provided by the OWNER. The OWNER may reinstate the retainage up to ten percent (10%) if the OWNER determines, at its discretion, that the FIRM is not making satisfactory progress toward final completion of the Work or where there is other specific cause for such withholding.
 5. Partial payment may be made for the delivered cost of stored materials planned for incorporation into the Work, provided such materials meet the requirements of this Contract, the Contract Drawings, and the Specifications, and are delivered and suitably stored at the project site, or at another location acceptable to the OWNER. Such material must be stored in a secure manor acceptable to the OWNER, and in accordance with the manufacturer's recommendations.
 6. The delivered cost of such stored or stockpiled materials may be included in any subsequent application for payment provided the FIRM meets the following conditions:
 - a. An applicable purchase order or supplier's invoice is provided listing the materials in detail, the cost of each item, and identifies this specific contract by name.
 - b. The materials are fully insured against loss or damage (from whatever source) or disappearance prior to incorporation into the Work.
 - c. Stored materials approved for payment by the OWNER shall not be removed from the designated storage area except for incorporation into the Work.

- d. Evidence that the FIRM has verified quantity and quality of the materials delivered (verified packing list).
7. It is further agreed between the parties that the transfer of title and the OWNER's payment for any stored or stockpiled materials pursuant to these General Conditions, and any applicable provisions of the Supplementary General Conditions, shall in no way relieve the FIRM of the responsibility of ensuring the correctness of those materials and for furnishing and placing such materials in accordance with the requirements of this Contract, the Contract Drawings, the Technical Specifications, and any approved changes thereto.
8. The following monthly Application for Progress Payment shall be accompanied by Bills of Sale, copies of paid invoices, releases of lien, or other documentation warranting that the FIRM has received the stored materials and equipment free and clear of all liens, charges, security interests, and encumbrances (which are hereinafter in these General Conditions referred to as "Liens") and evidence that the stored materials and equipment are covered by appropriate property insurance and other arrangements to protect the OWNER's interest therein, all of which shall be satisfactory to the OWNER.
9. The FIRM shall warrant and guarantee that title to all Work, materials, and equipment covered by an Application for Progress Payment, whether incorporated in the Work or not, will pass to the OWNER no later than the time of Final Payment free and clear of all liens or other encumbrances.
10. Progress Payments shall be made in accordance with the Local Government Prompt Payment Act. In the event any dispute with respect to any payment or pay request cannot be resolved between the FIRM and OWNER's project staff, FIRM may, in accordance with the alternative dispute resolution requirements of Florida Statute section 218.72, *et seq*, demand in writing a meeting with and review by the OWNER'S (agency) director. In the absence of the agency director, a

deputy director may conduct the meeting and review. Such meeting and review shall occur within ten (10) business days of receipt by OWNER of FIRM's written demand. The OWNER's manager, shall issue a written decision on the dispute within ten (10) business days of such meeting. This decision shall be deemed the OWNER's final decision for the purposes of the Local Government Prompt Payment Act.

11. The OWNER may refuse to make payment of the full amount because claims have been made against the OWNER on account of the FIRM's performance of the Work, or because Liens have been filed in connection with the Work, or there are other items entitling the OWNER to a credit against the amount recommended, but the OWNER must give the FIRM written notice within twenty (20) business days after the date on which the invoice is stamped as received which specifies the invoice deficiency and any action necessary to make the invoice complete and proper.

Section 8 – Responsibilities

The FIRM shall, under no circumstance, look to the OWNER to provide any labor or equipment for the FIRM. The FIRM shall provide all of the labor and equipment necessary to perform the job or services contracted for at the expense of the FIRM. Property of any kind that may be on the premises, which are the site of the performance of this contract, during the performance of this Work Authorization, shall be at the sole risk of the FIRM.

- 8.1** The OWNER hereby designates Joe Stephens as the OWNER's representative.
- 8.2** In addition to applicable provisions of Section 2 of the AGREEMENT, the OWNER will:
- Provide copies of existing drawings and equipment cut sheets if requested by FIRM
 - Pay for any required permit fees

The FIRM acknowledges and understands that it is an independent contractor in its relationship with the OWNER. The FIRM hereby designates Nico Shaner as the FIRM's representative.

Section 9 – Insurance

The FIRM shall provide certificate of insurance to the OWNER setting forth the type and amount of insurance carried by the FIRM and conforming to the minimum requirements set forth in the AGREEMENT.

Section 10 – Level of Service

The OWNER shall have the right to terminate said Agreement by giving the FIRM thirty (30) days written notice if the service that is being provided is not maintained at levels necessary to provide the required service. The OWNER will determine in its sole judgment what constitutes a satisfactory level of service.

Section 11 – Indemnification

The Firm shall indemnify and hold harmless the Owner and its officers and employees as set forth in Section 11 of the Agreement.

IN WITNESS WHEREOF, this Work Authorization, consisting of ten (10) pages and Attachment A has been caused fully executed on behalf of the FIRM by its duly authorized officer, and the OWNER has the same to be duly name and in its behalf, effective as of the date herein above written.

CORAL SPRINGS IMPROVEMENT DISTRICT

Signature of Witness

Signature of President

Printed name of Witness

Dr. Marty Shank
Printed Name of President

Date

Approved as to form and legality

District Counsel

FIRM

State of Florida
County of Palm Beach

Company

The foregoing instrument was acknowledged before me on this

___ day of _____, 2019 by

Signature

who is personally known to me OR produced _____ as identification.

Troy Lyn, P.E., Vice President
Name and Title (typed or printed)

Signature of Notary

August 19, 2019
Date

Attachment A

Budget Summary



Takeoff Worksheet

08/02/19

**Coral Springs Improvement Dist
151175 CSID Well 9 VFD & Electrical Improvements**

Assembly#	Part#	Description	Unit	Quantity	Ext. Price
Job: 151175 CSID Well 9 VFD & Electrical Improvements					
	Bid Item: 1	General Conditions			
		General Conditions	LOT	1.00	8,710.00
				Bid Item Totals:	8,710.00
	Bid Item: 2	Sitework			
		MOB/DEMOB	LOT	1.00	1,340.00
		Off Load VFD	LOT	1.00	542.00
		Punch Out Crew	CR-D	1.00	1,472.71
		Chain Link Fence	LOT	1.00	4,306.75
				Bid Item Totals:	7,661.46
	Bid Item: 5	Misc Metals			
		Misc Metals & Fasteners	LOT	1.00	2,461.00
		Installation	CR-D	1.00	1,793.67
				Bid Item Totals:	4,254.67
	Bid Item: 13	I&C			
		VFD	LOT	1.00	44,298.00
		Programming	LOT	1.00	2,875.00
		RTU Mods	LOT	1.00	3,691.50
		Pump Cable Seal & SS Fittings	LOT	1.00	615.25
		Installation	CR-D	1.00	1,793.67
				Bid Item Totals:	53,273.42
	Bid Item: 16	Electrical			
		Electrical Sub	LOT	1.00	11,200.00
				Bid Item Totals:	11,200.00

Takeoff Worksheet

08/02/19

Continued...

Assembly#	Part#	Description	Unit	Quantity	Ext. Price
Bid Item:	18	Rental Equipment			
		Equipment to Transport & Install VFD	LOT	1.00	2,153.38
		Misc Tools & Equipment	LOT	1.00	246.07
				Bid Item Totals:	2,399.45
Bid Item:	25	Allowance			
		Allowance	LOT	1.00	2,000.00
				Bid Item Totals:	2,000.00
Bid Item:	50	Engineering/Record Drawing			
		Engineering	LOT	1.00	7,500.00
				Bid Item Totals:	7,500.00
				Grand Totals:	96,999.00

11D

WORK AUTHORIZATION 163

No. GT-151165

Pursuant to the provisions contained in the "Contract for Professional Engineering Consulting and Design-Build Services on a Continuing Contract Basis " between the CORAL SPRINGS IMPROVEMENT DISTRICT, hereinafter referred to as "OWNER", and Globaltech, Inc., hereinafter referred to as "FIRM", dated July 1, 2012 (hereinafter referred to as "AGREEMENT"), this Work Authorization, executed this ____ day of _____ 2018, authorizes the FIRM to provide services under the terms and conditions set forth herein and in the AGREEMENT, which is incorporated herein by reference as though set forth in full.

The OWNER desires design-build services related to Production Well 5 Re-Development, hereinafter referred to as the "Specific Project".

Section 1 – Terms

The FIRM shall be defined as an individual, corporation or contractor having a direct contract with the OWNER or with any other subcontractor in the performance of a part of the work contracted for under the terms of this Work Authorization with the OWNER.

Section 2 – Scope of Work

The FIRM will provide the following services in accordance with Sections 1 and 2 of the AGREEMENT:

In March 2018, OWNER observed excessive sand in the strainers at the Water Treatment Plant. The source of the sand was traced back to Production Well 5 located in Whispering Oaks Park off of NW 102nd Terrace. The well was reconstructed in 2012 by AMPS well services under a previous work authorization, A video inspection was conducted on Production Well 5 that detected visible voids in the gravel pack and significant quantities of sand being produced under normal production flow conditions. FIRM was requested to prepare Work Authorization (WA) 163 to redevelop the production well to reduce sand production.

This scope of work contained in this WA generally consists of the following tasks:

- Coordination with various regulatory and municipal agencies.
- Contract water well services through a licensed drilling contractor.
- Contract professional hydrogeologic consulting to oversee and direct the redevelopment activities.
- Redevelop Production Well 5 using air surging, jetting and high rate pumping.
- Test the well to confirm that water production (flow) and water quality (sand production) are within acceptable levels.
- Provide and install new stainless-steel well flange
- Reassemble Production Well 5 installing existing 50 Hp submersible motor and pump. The original pump column, safety cable, level sensor and power connections will be reused, while the O-rings and Certa-lok spline will be replaced.
- Restore the site around Well 5 to preconstruction conditions.

Task 1 – Project Management and Coordination

This task includes project management and coordination with local regulatory, municipal, professional hydrogeological and well drilling services. Task 1 will include the following services:

- Meet with the OWNER to review the overall activity and schedule.
- Meet with OWNER to review redevelopment and testing protocols.
- Prepare detailed construction schedule to include as a minimum; site mobilization, redevelopment duration and anticipated date when Production Well 5 will be returned to service.
- Prepare subcontract for professional hydrogeological services with Connect Consulting.
- Prepare subcontract for well development services with licensed well drilling contractor.

- Notify Florida Department of Environmental Protection (FDEP) of impending work.
- Notify City of Coral Springs Parks Department that work will occur near their facility at Whispering Oaks Park. It is anticipated that this will be a courtesy activity only and that permitting will not be required.
- Notify CSID Drainage Department of our intent to discharge development water into their canal (Canal L-104).
- Review, administer, and track subcontractor work and pay requests.
- Schedule and conduct meetings, inspections, and testing with OWNER's staff.
- Oversee reassembly of Production Well 5.
- Oversee site restoration of the area surrounding Production Well 5 as needed.

Task 2 – Professional Hydrogeological Services

Professional Hydrogeological Services will be provided by Connect Consulting, Inc., under the direction of FIRM. Connect Consulting, Inc., (CCI) will provide the following services:

- Prepare redevelopment protocol.
- Review redevelopment protocol with drilling subcontractor (Centerline) and solicit bid to execute work.
- Recommend drilling subcontractor.
- Evaluate redevelopment progress through daily correspondence with drilling contractor and through periodic site visits at milestone events.
- Modify re-development approach based on measured progress.
- Provide personnel to oversee key phases of redevelopment and testing.
- Evaluate the effectiveness of re-development activities and make recommendations to OWNER on alternative approaches.

Task 3 – Well 5 Re-development, Testing and Reassembly

This task consists of well drilling services and will be subcontracted to a licensed well drilling contractor under the direction of FIRM. Task 3 activities include the following:

- Mobilize to Production Well 5 with the equipment necessary to implement the detailed scope of services. Furnish all labor, equipment and materials necessary to re-develop and test Production Well 5.
- Set up a water settling system that will accept water and sediment discharges from the well such that the water and solids will be contained by the system without significant flooding of the site. Settling tanks or other devices shall be used to separate sand from the well discharge water prior to discharge into a catch basin on NW 102 Avenue.
- Disassemble the well head and return exiting pump and motor to CSID Water Plant.
- Prepare detailed drawing for new machined well flange. Review drawing with OWNER. If possible, a 3-inch nipple will be provided and welded atop the well flange for the OWNER's camera.
- Conduct (at subcontractor's expense) video survey of the well prior to beginning re-development activities.
- Perform mechanical cleaning (brushing) of well screen. Perform air lift development to remove debris.
- Perform combination of air lift development and high rate jetting to remove fines from gravel pack and adjacent formation (total 80 hours)
- Add gravel to the filter pack that may have settled or been displaced as the result of redevelopment activities (up to 60 cubic feet included in base bid)
- Perform up to 30 hours of high rate pumping development as directed by the field hydrogeologist.

- Conduct a three (3) step drawdown test in accordance with Attachment B.
- Perform additional development as directed by hydrogeologist, FIRM and OWNER (funding provided through allowance).
- Install well flange plate and new gasket.
- Reinstall existing 50 Hp motor and pump (provided by OWNER) and the existing column, electrical wiring, level sensor, and wellhead to the extent the well is ready for service and use by OWNER. Megger motor wire as pump is being reinstalled.
- Disinfect Well 5 with sodium hypochlorite so that bacteriological test samples for coliform can be collected by OWNER and confirmed absent as required by the FDEP.
- Clean up, restore site and demobilize equipment.
- Conduct all redevelopment and construction methods in accordance with the latest revisions of the American Water Works Association Standards for Wells (AWWA A100-06) and the National Water Well Association Standards as that apply to the particular needs or conditions encountered in the proposed work.

Assumptions

Assumptions for the project are as follows:

1. No permitting fees will be required.
2. A maintenance of traffic (MOT) plan will not be required.
3. Following the completion of development and re-assembly of the well, OWNER will be responsible for microbiological sample collection and analysis.
4. OWNER to disconnect and reconnect main power and lock out cabinet.
5. OWNER to provide operational 50 Hp motor and pump.
6. Water produced during redevelopment will be directed into CSID L-104. Water will not be containerized or removed from the site.

7. Water used for jetting (if performed) will be provided by CSID from a nearby hydrant (located at 660 NW 101 Terrace). FIRM will acquire a meter from CSID.
8. Re-development time for Production Well 5 will be monitored on an hourly basis and reviewed with OWNER. Unused or extra time will be refunded or billed to OWNER at the rates provided by the drilling subcontractor.
9. The gravel pack around Well 5 is assumed to be non-cemented. The hydrogeologist will assess the condition of the gravel pack following the initial air development. Should the gravel pack fail to fluidize and settle during air-lifting (following the initial treatment), the hydrogeologist will consult with OWNER about the need to attempt alternate development methodologies.
10. An allowance of \$22,410 is included with this work authorization to address unforeseen repair requirements or additional well development. Access to allowance will only be made with direct, written authorization by OWNER. Unspent allowance will be returned to OWNER in a project amendment following the completion of the project.

Section 3 – Location

The services to be performed by the FIRM shall be on the following site or sites: Well 5 (Whispering Oaks Park – NW 102nd Terrace).

Section 4 – Deliverables

The FIRM will provide the following Deliverables to OWNER:

- Redevelopment Plan for Production Well 5.
- Notification to Florida Department of Environmental Protection and City of Coral Springs Parks Department.
- Technical memorandum of work performed and well performance parameters following re-development (including copies of pre- and post-development video surveys).

Section 5 - Time of Performance

Project will commence after execution of this Work Authorization and a Notice to Proceed is issued by OWNER. The FIRM and OWNER agree to the following schedule:

Task	Time Elapsed to Subtask Completion
Notice to Proceed (NTP)	0 Days
Mobilization	45 days following NTP
Well Redevelopment	75 days following NTP
Well Disinfection	79 days following NTP
Well Returned to Service	80 days following NTP
Site Restoration	90 days following NTP

Section 6 - Method and Amount of Compensation

1. The FIRM shall be paid by the OWNER in accordance with the Florida's Prompt Payment Act Florida Statute 218.70-79 and in accordance with the payment method as set forth in Section 6 of the AGREEMENT. The calculations shall begin using the date the invoice was received.
2. Total job price: **\$94,500.00**. The Base Price includes an allowance of \$22,410 for potential additional work.
3. On the terms contained in the FIRM's said proposal for the doing of said work and the said award therefore, and the specifications herein specifically referred to and made a part of this contract.
4. The cost for the above scope of services is a Lump Sum Price (LSP). The LSP is based on the materials, methods, and assumptions presented in the scope of services and may be adjusted downward based on final detail design and alternative selections or omissions. The LSP shall not be greater than the stated amount unless there is an approved increase in the scope of services. The final stipulated sum (adjusted LSP) submitted herein shall be an amount to be billed on the basis of "percent complete" and stored materials turned over to the OWNER.

Section 7 – Application for Progress Payment

1. Unless otherwise prescribed by law, at the end of each month, the FIRM shall submit to the OWNER for review, an Application for Progress Payment filled out and signed by the FIRM covering the Work completed as of the date of the Application and accompanied by such supporting documentation as is required by the AGREEMENT.
2. The Application for Progress Payment shall identify the amount of the FIRM Total Earnings to Date based upon value of original contract Work performed to date as approved by fully executed Change Orders.
3. Payment shall be based upon percentage of work completed based upon the approved schedule of values. Retainage in the amount of 10% will be withheld on the calculated value of any work, with the exception of stored materials which may be paid at the supplier's invoiced cost. At FIRM's request, after 50% completion of the work has been achieved, the OWNER will implement a reduction in retainage to 5% of all future pay requests. If retainage is reduced, FIRM may not withhold more than 5% retainage from subcontractors or suppliers and will be required to certify compliance with F.S. 218.70 *et seq* on each subsequent pay application. Notwithstanding the foregoing, in no instance can the amount retained be less than the value of OWNER's good faith claims plus the value of the work the OWNER determines remains to be put in place or required to be performed as remedial activities. For the purposes of this section, 50% completion shall be that point in time when OWNER determines that half of the Work required by the Contract has been completed. In no event shall the Work be determined to be 50% completed before the OWNER has paid 50% of the Contract amount and 50% of the Contract time has expired. The amount of previous Pay Estimate payments shall then be subtracted to equal the Balance Due during the Pay Estimate period.
4. When the OWNER determines the Work to be Substantially Complete, the OWNER may reduce the retainage to five percent (5%) of the dollar value of all Work satisfactorily completed to date, provided that the FIRM is

making satisfactory progress toward Final Completion of the Work, that in the opinion of the OWNER there is no specific cause for a greater retainage, and the FIRM obtains the written consent of the Surety Companies furnishing the required Public Construction Bond on consent forms provided by the OWNER. The OWNER may reinstate the retainage up to ten percent (10%) if the OWNER determines, that the FIRM is not making satisfactory progress toward final completion of the Work or where there is other specific cause for such withholding.

5. Partial payment may be made for the delivered cost of stored materials planned for incorporation into the Work, provided such materials meet the requirements of this Contract, the Contract Drawings, and the Specifications, and are delivered and suitably stored at the project site, or at another location acceptable to the OWNER. Such material must be stored in a secure manor acceptable to the OWNER, and in accordance with the manufacturer's recommendations.
6. The delivered cost of such stored or stockpiled materials may be included in any subsequent application for payment provided the FIRM meets the following conditions:
 - a. An applicable purchase order or supplier's invoice is provided listing the materials in detail, the cost of each item, and identifies this specific contract by name.
 - b. The materials are fully insured against loss or damage (from whatever source) or disappearance prior to incorporation into the Work.
 - c. Stored materials approved for payment by the OWNER shall not be removed from the designated storage area except for incorporation into the Work.
 - d. Evidence that the FIRM has verified quantity and quality of the materials delivered (verified packing list).
7. It is further agreed between the parties that the transfer of title and the OWNER's payment for any stored or stockpiled materials pursuant to these

General Conditions, and any applicable provisions of the Supplementary General Conditions, shall in no way relieve the FIRM of the responsibility of ensuring the correctness of those materials and for furnishing and placing such materials in accordance with the requirements of this Contract, the Contract Drawings, the Technical Specifications, and any approved changes thereto.

- 8. The following monthly Application for Progress Payment shall be accompanied by Bills of Sale, copies of paid invoices, releases of lien, or other documentation warranting that the FIRM has received the stored materials and equipment free and clear of all liens, charges, security interests, and encumbrances (which are hereinafter in these General Conditions referred to as "Liens") and evidence that the stored materials and equipment are covered by appropriate property insurance and other arrangements to protect the OWNER's interest therein, all of which shall be satisfactory to the OWNER.**
- 9. The FIRM shall warrant and guarantee that title to all Work, materials, and equipment covered by an Application for Progress Payment, whether incorporated in the Work or not, will pass to the OWNER no later than the time of Final Payment free and clear of all liens or other encumbrances.**
- 10. In the event any dispute with respect to any payment or pay request cannot be resolved between the FIRM and OWNER's project staff, FIRM may, in accordance with the alternative dispute resolution requirements of Florida Statute section 218.72, *et seq*, demand in writing a meeting with and review by the OWNER'S (agency) director. In the absence of the agency director, a deputy director may conduct the meeting and review. Such meeting and review shall occur within ten (10) business days of receipt by OWNER of FIRM's written demand. The OWNER's manager shall issue a written decision on the dispute within ten (10) business days of such meeting. This decision shall be deemed the OWNER's final decision for the purposes of the Local Government Prompt Payment Act.**

Section 8 – Responsibilities

The FIRM shall, under no circumstance, look to the OWNER to provide any labor or equipment for the FIRM. The FIRM and its Subcontractors shall provide all of the labor and equipment necessary to perform the job or services contracted for at the expense of the FIRM. Property of any kind that may be on the premises, which are the site of the performance of this contract, during the performance of this Work Authorization, shall be at the sole risk of the FIRM.

- 8.1** The OWNER hereby designates Joe Stephens as the OWNER's representative.
- 8.2** In addition to applicable provisions of Section 2 of the AGREEMENT, the OWNER will:
- Provide access to potable water
 - Collect and conduct microbiological analysis
 - Permit equipment storage at OWNER's water treatment plant

The FIRM acknowledges and understands that it is an independent contractor in its relationship with the OWNER. The FIRM hereby designates Rick Olson, P.E. as the FIRM's representative.

Section 9 – Insurance

The FIRM shall provide certificate of insurance to the OWNER setting forth the type and amount of insurance carried by the FIRM and conforming to the minimum requirements set forth in the AGREEMENT.

Section 10 – Level of Service

The OWNER shall have the right to terminate said Agreement by giving the FIRM thirty (30) days written notice if the service that is being provided is not maintained at levels necessary to provide the required service. The OWNER will determine in its sole judgment what constitutes a satisfactory level of service.

Section 11 – Indemnification

The Firm shall indemnify and hold harmless the Owner and its officers and employees as set forth in Section 11 of the Agreement.

IN WITNESS WHEREOF, this Work Authorization, consisting of thirteen (13) pages and Attachments A & B has been caused fully executed on behalf of the FIRM by its duly authorized officer, and the OWNER has the same to be duly name and, in its behalf, effective as of the date herein above written.

(SEAL)

CORAL SPRINGS IMPROVEMENT DISTRICT

ATTEST:

President

Printed name of Witness

Printed name

Date

Approved as to form and legality

Printed name of Witness

District Counsel

Printed name of Witness

State of Florida
County of Palm Beach

ENGINEER

Globaltech Inc.
Company

The foregoing instrument was acknowledged before me on this

___ day of _____, 2019 by

Signature

who is personally known to me OR produced _____ as identification.

Troy L. Lyn, Vice President

Name and title (typed or printed)

Signature of Notary

July 15, 2019

Date

Attachment A

Budget Summary



Takeoff Worksheet

06/28/19

**Coral Springs Improvement Dist
151165 CSID Well 5 Rehab**

Assembly#	Part#	Description	Unit	Quantity	Ext. Price
Job: 151165 CSID Well 5 Rehab					
	Bid Item: 1	Project Management and Coordination			
		Project Management and Coordination	LOT	1.00	9,500.00
				Bid Item Totals:	9,500.00
	Bid Item: 2	Professional Hydrogeological Services			
		Connect Consulting	LOT	1.00	10,000.00
				Bid Item Totals:	10,000.00
	Bid Item: 3	Well Redevelopment, Testing & Reassembly			
		Drilling Contractor	LOT	1.00	32,700.00
				Bid Item Totals:	32,700.00
	Bid Item: 4	Mechanical			
		New SS Well Flange	LOT	1.00	11,074.50
		New Adapter Pump Column		1.00	2,214.90
		Flange Kits & Misc Materials	LOT	1.00	1,476.60
				Bid Item Totals:	14,766.00
	Bid Item: 5	Subcontractor Markup			
		Subcontractor Markup	LOT	1.00	5,124.00
				Bid Item Totals:	5,124.00
	Bid Item: 6	Allowance			
		Allowance	LOT	1.00	22,410.00
				Bid Item Totals:	22,410.00
				Grand Totals:	94,500.00

Twelfth Order of Business



June 28, 2019

Coral Springs Improvement District
10300 NW 11th Manor
Coral Springs, FL 33071
Attn: Joe Stevens

**Re: CITY OF SUNRISE
CONTRACT #19-10-12-VH**

Aquifer Maintenance & Performance Systems, Inc. (AMPS, Inc.) agrees to allow the Coral Springs Improvement District to piggyback our existing contract with the City of Sunrise (contract #19-10-12-VH) with the same terms, conditions, specifications & pricing. The scope of work includes but is not limited to:

*Line items 1 through 6, the complete contract as needed

*Monthly monitoring: Contractor shall monitor/test each well monthly & submit a report to the client representative

*Recommended monthly non-chemical EMT injections (Section 1.8 item B) on an as needed basis to maintain optimum performance & quality. Wells will be determined from the monitoring, the wells will set for 24 hours and then be flushed

*AMPS will guarantee that actual well performance will be maintained at no less than 80% of rehabilitated specific capacity on the Coral Springs Improvement District wellfield. 2 additional injections will be performed and, if no change, a rehabilitation will be performed at 1/2 price.

The above is agreeable to both Aquifer Maintenance & Performance Systems, Inc. & Coral Springs Improvement District.

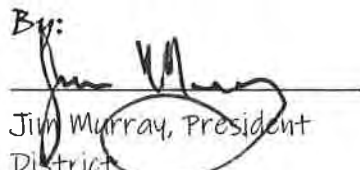
By: 
Jim Murray, President
District
AMPS, Inc.

Coral Springs Improvement

Date: 6/28/19

Date: _____

- 1.7 Airlift residual chemicals.
- 1.8 Perform Descaling of Well with One of the Two Methods below (A. or B.):

A. Acid Descaling:

1. Prepare wellhead for acid.
2. Install injection equipment.
3. Inject 500 gallons of 15% acid.
4. Airlift spent acid (direct air method).
5. Repeat acid treatment.

B. Electromagnetic Descaling:

1. Prepare wellhead for descaling.
2. Install electromagnetic descaling equipment.
3. Inject 2000 gallons of electromagnetic descaling solution.
4. Airlift debris (direct air method).
5. Repeat electromagnetic descaling treatment, if needed.

- 1.9 Post chlorination. Disinfection of the well is in accordance with AWWA Standard C654-97 Disinfection of Wells.
- 1.10 Reset pump and perform specific capacity test.
- 1.11 Post treatment color video survey.
- 1.12 Test Specific Capacity (SC)* after each well rehabilitation is completed.

2. *Specific Capacity (SC) can be checked via air line readings. In collecting data for the calculation it is critical to measure the water levels only after they have stabilized. SC guidelines (AWWA OPFLOW January 2002) are:

- Full recovery of capacity is probable with normal rehabilitation work if SC current is greater than 85% of SC original.
- Full recovery of capacity may still be possible, but more extensive work will be needed if SC current is less than 85% of SC original but greater than 60% of SC original.
- Full recovery of capacity is unlikely if SC current is less than 60% of SC original.
- The well may be unsalvageable if the SC drops below 40% of the original.

3. Contractor shall have all necessary equipment to perform a well rehabilitation. This equipment should include casing brushes, jet tools, reverse isolation tools and fishing tools.

E. BID LINE ITEM 4 - CALIBRATION OF FLOW METERS:

1. The Contractor shall calibrate, for City of Sunrise, sixteen (16) flow meters at the Springtree facility (4350 Springtree Drive, Sunrise, Florida 33351) at least once per year. Calibration shall meet State of Florida, Department of Environment (DEP) standards.
2. The City reserves the right to add flow meters/locations, as required and in the best



CERTIFICATE OF LIABILITY INSURANCE

DATE (MM/DD/YYYY)
05/08/2019

THIS CERTIFICATE IS ISSUED AS A MATTER OF INFORMATION ONLY AND CONFERS NO RIGHTS UPON THE CERTIFICATE HOLDER. THIS CERTIFICATE DOES NOT AFFIRMATIVELY OR NEGATIVELY AMEND, EXTEND OR ALTER THE COVERAGE AFFORDED BY THE POLICIES BELOW. THIS CERTIFICATE OF INSURANCE DOES NOT CONSTITUTE A CONTRACT BETWEEN THE ISSUING INSURER(S), AUTHORIZED REPRESENTATIVE OR PRODUCER, AND THE CERTIFICATE HOLDER.

IMPORTANT: If the certificate holder is an ADDITIONAL INSURED, the policy(ies) must have ADDITIONAL INSURED provisions or be endorsed. If SUBROGATION IS WAIVED, subject to the terms and conditions of the policy, certain policies may require an endorsement. A statement on this certificate does not confer rights to the certificate holder in lieu of such endorsement(s).

PRODUCER Marsh USA, Inc. 1166 Avenue of the Americas New York, NY 10036 Attn: Atlanta Certrequest@marsh.com	CONTACT NAME: PHONE (A/C, No, Ext): FAX (A/C, No): E-MAIL ADDRESS: <table style="width: 100%; border: none;"> <tr> <td style="text-align: center; border: none;">INSURER(S) AFFORDING COVERAGE</td> <td style="text-align: center; border: none;">NAIC#</td> </tr> <tr> <td style="border: none;">INSURER A : Illinois National Insurance Company</td> <td style="border: none;">23817</td> </tr> <tr> <td style="border: none;">INSURER B :</td> <td style="border: none;"></td> </tr> <tr> <td style="border: none;">INSURER C :</td> <td style="border: none;"></td> </tr> <tr> <td style="border: none;">INSURER DR</td> <td style="border: none;"></td> </tr> <tr> <td style="border: none;">INSURER E :</td> <td style="border: none;"></td> </tr> <tr> <td style="border: none;">INSURER F :</td> <td style="border: none;"></td> </tr> </table>	INSURER(S) AFFORDING COVERAGE	NAIC#	INSURER A : Illinois National Insurance Company	23817	INSURER B :		INSURER C :		INSURER DR		INSURER E :		INSURER F :	
INSURER(S) AFFORDING COVERAGE	NAIC#														
INSURER A : Illinois National Insurance Company	23817														
INSURER B :															
INSURER C :															
INSURER DR															
INSURER E :															
INSURER F :															
342881-FL-WC-19-20 781021															
INSURED DecisionHR, Inc. 11101 Roosevelt Blvd N St. Petersburg, FL 33716															

COVERAGES CERTIFICATE NUMBER: ATL-004923030-09 **REVISION NUMBER:** 1

THIS IS TO CERTIFY THAT THE POLICIES OF INSURANCE LISTED BELOW HAVE BEEN ISSUED TO THE INSURED NAMED ABOVE FOR THE POLICY PERIOD INDICATED. NOTWITHSTANDING ANY REQUIREMENT, TERM OR CONDITION OF ANY CONTRACT OR OTHER DOCUMENT WITH RESPECT TO WHICH THIS CERTIFICATE MAY BE ISSUED OR MAY PERTAIN, THE INSURANCE AFFORDED BY THE POLICIES DESCRIBED HEREIN IS SUBJECT TO ALL THE TERMS, EXCLUSIONS AND CONDITIONS OF SUCH POLICIES. LIMITS SHOWN MAY HAVE BEEN REDUCED BY PAID CLAIMS.

INSR LTR	TYPE OF INSURANCE	ADDL INSD	SUBR WVD	POLICY NUMBER	POLICY EFF (MM/DD/YYYY)	POLICY EXP (MM/DD/YYYY)	LIMITS
	COMMERCIAL GENERAL LIABILITY <input type="checkbox"/> CLAIMS-MADE <input type="checkbox"/> OCCUR GEN'L AGGREGATE LIMIT APPLIES PER: <input type="checkbox"/> POLICY <input type="checkbox"/> PRO-JECT <input type="checkbox"/> LOC OTHER:						EACH OCCURRENCE \$ DAMAGE TO RENTED PREMISES (Ea occurrence) \$ MED EXP (Any one person) \$ PERSONAL & ADV INJURY \$ GENERAL AGGREGATE \$ PRODUCTS - COMP/OP AGG \$ \$
	AUTOMOBILE LIABILITY <input type="checkbox"/> ANY AUTO <input type="checkbox"/> OWNED AUTOS ONLY <input type="checkbox"/> SCHEDULED AUTOS <input type="checkbox"/> HIRED AUTOS ONLY <input type="checkbox"/> NON-OWNED AUTOS ONLY <input type="checkbox"/> AUTOS ONLY						COMBINED SINGLE LIMIT (Ea accident) \$ BODILY INJURY (Per person) \$ BODILY INJURY (Per accident) \$ PROPERTY DAMAGE (Per accident) R \$ \$
	<input type="checkbox"/> UMBRELLA LIAB <input type="checkbox"/> OCCUR <input type="checkbox"/> EXCESS LIAB <input type="checkbox"/> CLAIMS-MADE DED RETENTION#						EACH OCCURRENCE \$ AGGREGATE \$ \$
A	WORKERS COMPENSATION AND EMPLOYERS' LIABILITY ANY PROPRIETOR/PARTNER/EXECUTIVE OFFICER/MEMBER EXCLUDED? (Mandatory in NH) If yes, describe under DESCRIPTION OF OPERATIONS below			WC 023540396	06/01/2019	06/01/2020	<input checked="" type="checkbox"/> PER STATUTE <input type="checkbox"/> ORH-FR R E.L. EACH ACCIDENT \$ 1,000,000 E.L. DISEASE - EA EMPLOYEE \$ 1,000,000 E.L. DISEASE - POLICY LIMIT \$ 1,000,000

DESCRIPTION OF OPERATIONS / LOCATIONS / VEHICLES (ACORD 101, Additional Remarks Schedule, may be attached if more space is required)
 Coverage is provided for only those employees leased to but not subcontractors of Aquifer Maintenance & Performance System

CERTIFICATE HOLDER Coral Springs Improvement District 10300 N.W. 11th manor Coral Springs, FL 33071	CANCELLATION SHOULD ANY OF THE ABOVE DESCRIBED POLICIES BE CANCELLED BEFORE THE EXPIRATION DATE THEREOF, NOTICE WILL BE DELIVERED IN ACCORDANCE WITH THE POLICY PROVISIONS. AUTHORIZED REPRESENTATIVE of Marsh USA Inc. Henry L. Whiting
---	---



CERTIFICATE OF LIABILITY INSURANCE

DATE (MM/DD/YYYY)

10/29/2018

THIS CERTIFICATE IS ISSUED AS A MATTER OF INFORMATION ONLY AND CONFERS NO RIGHTS UPON THE CERTIFICATE HOLDER. THIS CERTIFICATE DOES NOT AFFIRMATIVELY OR NEGATIVELY AMEND, EXTEND OR ALTER THE COVERAGE AFFORDED BY THE POLICIES BELOW. THIS CERTIFICATE OF INSURANCE DOES NOT CONSTITUTE A CONTRACT BETWEEN THE ISSUING INSURER(S), AUTHORIZED REPRESENTATIVE OR PRODUCER, AND THE CERTIFICATE HOLDER.

IMPORTANT: If the certificate holder is an ADDITIONAL INSURED, the policy(ies) must be endorsed. If SUBROGATION IS WAIVED, subject to the terms and conditions of the policy, certain policies may require an endorsement. A statement on this certificate does not confer rights to the certificate holder in lieu of such endorsement(s).

PRODUCER Townsend Insurance Services, LLC 5931 NW 61st Manor Parkland FL 33067		CONTACT NAME: Mike Gegerson PHONE (A/C, No, Ext): 954-540-7430 FAX (A/C, No): 954-951-1789 E-MAIL ADDRESS: mike@townsendinsuranceservices.com	
INSURED Aquifer Maintenance and Performance Systems Inc 7146 Haverhill Road North West Palm Beach FL 33407		INSURER(S) AFFORDING COVERAGE INSURER A: Landmark American Insurance Company INSURER B: Granite State Insurance Company INSURER CA INSURER DA INSURER EA INSURER F:	NAIC#

COVERAGES **CERTIFICATE NUMBER: CL18102901385** **REVISION NUMBER:**

THIS IS TO CERTIFY THAT THE POLICIES OF INSURANCE LISTED BELOW HAVE BEEN ISSUED TO THE INSURED NAMED ABOVE FOR THE POLICY PERIOD INDICATED. NOTWITHSTANDING ANY REQUIREMENT, TERM OR CONDITION OF ANY CONTRACT OR OTHER DOCUMENT WITH RESPECT TO WHICH THIS CERTIFICATE MAY BE ISSUED OR MAY PERTAIN, THE INSURANCE AFFORDED BY THE POLICIES DESCRIBED HEREIN IS SUBJECT TO ALL THE TERMS, EXCLUSIONS AND CONDITIONS OF SUCH POLICIES. LIMITS SHOWN MAY HAVE BEEN REDUCED BY PAID CLAIMS.

INSR LTR	TYPE OF INSURANCE	ADDL INSD	SUBR WVD	POLICY NUMBER	POLICY EFF (MM/DD/YYYY)	POLICY EXP (MM/DD/YYYY)	LIMITS
A	<input checked="" type="checkbox"/> COMMERCIAL GENERAL LIABILITY <input type="checkbox"/> CLAIMS-MADE <input checked="" type="checkbox"/> OCCUR GEN'L AGGREGATE LIMIT APPLIES PER: <input checked="" type="checkbox"/> POLICY <input type="checkbox"/> PRO-JECT <input type="checkbox"/> LOC <input type="checkbox"/> OTHER	X		LEC772588	10/28/2018	10/28/2019	EACH OCCURRENCE \$ 2,000,000 DAMAGE TO RENTED PREMISES (Ea occurrence) \$ MED EXP (Any one person) \$ 10,000 PERSONAL & ADV INJURY \$ 2,000,000 GENERAL AGGREGATE \$ 2,000,000 PRODUCTS - COMP/OP AGG \$ 2,000,000 Dmg Prem Rentd to You \$ 100,000
B	AUTOMOBILE LIABILITY <input checked="" type="checkbox"/> ANY AUTO <input type="checkbox"/> ALL OWNED AUTOS <input type="checkbox"/> SCHEDULED AUTOS <input type="checkbox"/> HIRED AUTOS <input type="checkbox"/> NON-OWNED AUTOS			02-CA-069971035-1	08/02/2018	08/02/2019	COMBINED SINGLE LIMIT (Ea accident) \$ 1,000,000 BODILY INJURY (Per person) \$ BODILY INJURY (Per accident) \$ PROPERTY DAMAGE (Per accident) \$ Uninsured motorist combined \$ 500,000
	UMBRELLA LIAB <input type="checkbox"/> OCCUR EXCESS LIAB <input type="checkbox"/> CLAIMS-MADE DED RETENTION\$						EACH OCCURRENCE \$ AGGREGATE \$
	WORKERS COMPENSATION AND EMPLOYERS' LIABILITY ANY PROPRIETOR/PARTNER/EXECUTIVE OFFICER/MEMBER EXCLUDED? (Mandatory in NH) If yes, describe under DESCRIPTION OF OPERATIONS below	Y/N	N/A				PER STATUTE OTH-ER E L EACH ACCIDENT \$ E L DISEASE - EA EMPLOYEE \$ E L DISEASE - POLICY LIMIT \$
A	Professional Liability			LEC772588	10/28/2018	10/28/2019	5,000 deductible 2,000,000
A	Pollution Liability			LEC772588	10/28/2018	10/28/2019	5,000 deductible 2,000,000

DESCRIPTION OF OPERATIONS / LOCATIONS / VEHICLES (ACORD 101, Additional Remarks Schedule, may be attached if more space is required)
Coral Springs Improvement District is listed as an additional insured with regards to the General Liability Policy per written Contract.

CERTIFICATE HOLDER Coral Springs Improvement District 10300 N.W. 11th manor Coral Springs, FL 33071	CANCELLATION SHOULD ANY OF THE ABOVE DESCRIBED POLICIES BE CANCELLED BEFORE THE EXPIRATION DATE THEREOF, NOTICE WILL BE DELIVERED IN ACCORDANCE WITH THE POLICY PROVISIONS. AUTHORIZED REPRESENTATIVE Mike Gegerson/MG 
---	--

ADDITIONAL COVERAGES

Ref #	Description PIP-Basic	Coverage Code PIP	Form No.	Edition Date	
Limit 1 10,000	Limit 2	Limit 3	Deductible Amount	Deductible Type	Premium
Ref #	Description	Coverage Code	Form No.	Edition Date	
Limit 1	Limit 2	Limit 3	Deductible Amount	Deductible Type	Premium
Ref #	Description	Coverage Code	Form No.	Edition Date	
Limit 1	Limit 2	Limit 3	Deductible Amount	Deductible Type	Premium
Ref #	Description	Coverage Code	Form No.	Edition Date	
Limit 1	Limit 2	Limit 3	Deductible Amount	Deductible Type	Premium
Ref #	Description	Coverage Code	Form No.	Edition Date	
Limit 1	Limit 2	Limit 3	Deductible Amount	Deductible Type	Premium
Ref #	Description	Coverage Code	Form No.	Edition Date	
Limit 1	Limit 2	Limit 3	Deductible Amount	Deductible Type	Premium
Ref #	Description	Coverage Code	Form No.	Edition Date	
Limit 1	Limit 2	Limit 3	Deductible Amount	Deductible Type	Premium
Ref #	Description	Coverage Code	Form No.	Edition Date	
Limit 1	Limit 2	Limit 3	Deductible Amount	Deductible Type	Premium
Ref #	Description	Coverage Code	Form No.	Edition Date	
Limit 1	Limit 2	Limit 3	Deductible Amount	Deductible Type	Premium
Ref #	Description	Coverage Code	Form No.	Edition Date	
Limit 1	Limit 2	Limit 3	Deductible Amount	Deductible Type	Premium
Ref #	Description	Coverage Code	Form No.	Edition Date	
Limit 1	Limit 2	Limit 3	Deductible Amount	Deductible Type	Premium
Ref #	Description	Coverage Code	Form No.	Edition Date	
Limit 1	Limit 2	Limit 3	Deductible Amount	Deductible Type	Premium
Ref #	Description	Coverage Code	Form No.	Edition Date	
Limit 1	Limit 2	Limit 3	Deductible Amount	Deductible Type	Premium

Thirteenth Order of Business

RESOLUTION 2019-9

A RESOLUTION OF THE CORAL SPRINGS IMPROVEMENT DISTRICT FORMALLY ADOPTING APPLICABLE PROVISIONS OF PART III OF CHAPTER 112, FLORIDA STATUTES AS ITS CODE OF ETHICS

WHEREAS, the Coral Springs Improvement District (the ‘District’) is a special purpose, local government created pursuant to Chapter 298, Florida Statutes, and special act of the Florida Legislature; and

WHEREAS, the Board of Supervisors of the District (the ‘Board’) has determined that it is appropriate to formally adopt a Code of Ethics; and

WHEREAS, it is the desire of the Board to adopt the applicable provisions of Part III of Chapter 112, Florida Statutes as its Code of Ethics;

NOW THEREFORE, BE IT RESOLVED BY THE BOARD OF SUPERVISORS OF THE CORAL SPRINGS IMPROVEMENT DISTRICT THAT:

Section 1. The Board hereby adopts the applicable provisions of Part III of Chapter 112, Florida Statutes, as its Code of Ethics.

PASSED AND ADOPTED by the Board of Supervisors of the Coral Springs Improvement District this 19th day of August, 2019.

CORAL SPRINGS IMPROVEMENT DISTRICT

Dr. Martin Shank, President

ATTEST:

Kenneth Cassel, Assistant Secretary

Fourteenth Order of Business

RESOLUTION 2019-10

A RESOLUTION OF THE BOARD OF SUPERVISORS OF CORAL SPRINGS IMPROVEMENT DISTRICT APPROVING ADOPTION AND EXECUTION OF THE STATEWIDE MUTUAL AID AGREEMENT.

WHEREAS, the State of Florida Emergency Management Act, Chapter 252, authorizes the State and its political subdivisions to provide emergency aid and assistance in the event of a disaster or emergency; and

WHEREAS, the statutes also authorize the State to coordinate the provision of any equipment, services, or facilities owned or organized by the State or its political subdivisions for use in the affected area upon the request of the duly constituted authority of the area; and

WHEREAS, this Resolution authorizes the request, provision, and receipt of interjurisdictional mutual assistance in accordance with the Emergency Management Act, Chapter 252, among political subdivisions within the State; and

NOW, THEREFORE, be it resolved by Coral Springs Improvement District that in order to maximize the prompt, full and effective use of resources of all participating governments in the event of an emergency or disaster we hereby adopt the Statewide Mutual Aid Agreement which is attached hereto and incorporated by reference as **Exhibit "A"**.

PASSED AND ADOPTED by the Board of Supervisors of Coral Springs Improvement District this 19th day of August, 2019.

ATTEST:

CORAL SPRINGS IMPROVEMENT DISTRICT

Secretary/Asst. Secretary

I certify that the foregoing is an accurate copy of Resolution 2019-10

Chairman

Date: _____

Exhibit A: Statewide Mutual Aid Agreement

Fifteenth Order of Business

PROGRAM SUMMARY

BSI Online offers full control and access over your backflow program. You always see customer service notes, letters sent from our office, tests entered and access to your data. Since our program is web based, you can access your program anytime, anywhere, and on any device ... in real-time!



PROGRAM START

All existing backflow assemblies within your municipality will be added to the BSI Online database by BSI staff. We can typically get your program running in 30-60 days from the time we receive records.



TESTER NOTIFICATION

BSI will notify the testing community, inform them of the new program procedures, and help them create a profile with their current license(s) and test gauge calibration(s).



CUSTOMER NOTIFICATION & ACCESS

BSI sends up to 2 letter notifications to water customers via USPS informing them of their testing requirements. Our customer portal includes a list of testers and an opt-in email notification once their test is submitted.



REPORT ENTRY

Test reports are entered by the tester on our website. Our test forms are set to State standards. We also track tester credentials, ensuring each test submitted is accurate. The tester will pay a \$12.95 filing fee per test report submitted.

Questions? Contact Us!

marketing@backflow.com | [800.414.4990](tel:800.414.4990) | backflow.com

CUSTOMER SERVICE



Customer service inquiries from water customers, testing companies, and the water purveyor are handled by our office. Our contact information is listed on all notification letters, allowing BSI to handle the clerical and administrative tasks for you.

REPORTING



We developed a comprehensive dashboard and report tab, allowing you to query data sets on your program. These queries are normally used for state/regulatory reporting.

SECURITY



All water customers are protected by a customer confirmation number (CCN), keeping their information private. All data is also backed up multiple times a day, on separate, off site servers.

EXPERIENCED CONSULTING



BSI Online can and will provide consulting / representation services on all backflow related issues or concerns for the duration of the agreement.

**TOTAL ANNUAL COST FOR
BSI ONLINE: \$495.00!**

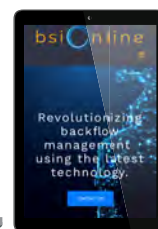

Questions? Contact Us!

marketing@backflow.com | 800.414.4990 | backflow.com

ANNUAL SUBSCRIPTION AGREEMENT

Effective this _____ day of _____, 2019, Backflow Solutions, Inc., an Illinois corporation (“BSI”) and Coral Springs Improvement District of Florida (the “District”) hereby enter into an online subscription agreement whereby BSI will perform certain notification and data management functions on behalf of Coral Springs Improvement District. The District will provide BSI with the information described hereafter and require that all companies that perform mandated backflow assemblies’ tests within the District be directed to the BSI website to enter the result of each Backflow Test performed within the District Jurisdiction.

1. **BSI Responsibilities.** In addition to any other responsibilities set forth elsewhere in this agreement, BSI shall, through the use of its proprietary software, BSI Online.

a. Maintain the secure Online Database to insure a functional backflow assembly tracking system that is easy to understand and use by licensed testers. BSI shall also maintain an internet website where testers shall input all data related to Backflow Tests they conduct within the District’s jurisdiction.

b. Send up to two (2) notices to water customers that have Assemblies, advising them that their Assembly is due for testing. To facilitate the testing procedure, the Test Due Notice will include the identity of the water customer’s last Tester of record, together with all relevant contact information, if information is available to BSI. At the time the Test Due Notice is mailed to the water customer, BSI will also transmit a notice to the last Tester of record advising that Tester that the water customer’s assembly is due to be tested. The Tester Notification is designed to increase test compliance, thereby reducing enforcement costs incurred by The District.

- i. The “Test Due Notice” shall be mailed approximately 30 days prior to the scheduled test date.
- ii. The “Overdue Notice” shall be sent 1 day after the Test Date has passed if Backflow Test results have not been entered to the Online Data Base. The Overdue Notice will advise the water customer of its delinquent test status.

c. BSI shall immediately transmit an electronic copy of each Test Report to the Municipality.

2. **Inducement.** The District acknowledges and agrees that in order to induce BSI to provide the service contemplated by this Agreement, for each Test Report submitted to the Online Data Base the Data Entry Charge of **\$12.95 per report shall be paid by the tester** prior to uploading the test data to the Online Data Base.

3. **Cost.** The District shall pay BSI the sum of \$495.00 per calendar year as the annual “Subscription Fee”.

4. **Termination.** If you wish to discontinue services provided by BSI we require 30 days written notice.

IN WITNESS WHEREOF, the parties have executed this Agreement as of the date first set forth above.

BACKFLOW SOLUTIONS, INC.,
An Illinois corporation

a body politic and corporate

By: _____

By: _____

Name: Melissa Joyce
Title: Sales & Marketing Associate
Address:
12609 South Laramie Ave.
Alsip, Illinois 60803

Name: _____
Title: _____
Address: _____

Sixteenth Order of Business



**Xylem Water Solutions USA, Inc.
Flygt Products**

15132 Park of Commerce Blvd./102
Jupiter, FL 33478
Tel (561) 848-1200
Fax (561) 848-1299

July 29, 2019

Coral Springs Improvement District
10300 NW 11th Manor
Coral Springs, FL. 33071

Subject: FLYGT PRODUCTS – SALES & SERVICE

Please be advised that Xylem Water Solutions USA Inc. owns the Flygt Corporation and is the only authorized vendor for Flygt Products and OEM Parts. Xylem is also the only authorized service repair and warranty organization in the State of Florida; (East of the Apalachicola River). Our staff is properly trained to provide you with original equipment, spare parts, repairs and warranty service.

Thank you for your interest in Xylem Water Solutions USA Inc. Please feel free to contact me if you have any questions regarding distribution or any other matter.

Xylem Water Solutions USA, Inc.

Sincerely,

Rick Reyes
Area Sales Representative
Flygt Products
M: 561-699-4077
SN:tn



Seventeenth Order of Business



Coral Springs Improvement District

10300 N.W. 11TH MANOR Coral Springs, FL 33071

6/28/19

TO: CSID Board Members

RE: Consideration to purchase two Doosan G70 Portable generators

CSID Board,

Thank you for your consideration to purchase two portable generators. The purpose of these generators is to further enhance our ability to supply portable power to wastewater lift stations in the event of an emergency.

The generator specifications of the model submitted are consistent with CSID Requirements, are similar to currently owned Generators and are available for purchase on the Florida Sheriffs Cooperative Purchasing Program (FSA) attached. They are also the lowest bidder (as specified)

Note: The standard FSA Specification #77 is for a 150 KW portable generator. All Vendors (bidders) were given the option of a downgrade and/or upgrade package as specified, including larger and smaller wattage outputs. The "specified downgrade packages" are expressed as a reduction in price from the 150 KW standard specification bid price, as we have opted to do. Please see Tabulation on next page

Regards,

A handwritten signature in blue ink, appearing to read "C. Dwiggin", is written over a light blue horizontal line.

Curtis J.L. Dwiggin
C.S.I.D. Field Manager

2019 Generator Price comp. 150 kw Portable generator (FSA Specification #77)

	Blue Star Power System	Chicago Pneumatic	Doosan	Generac/Magnum	LJP	TechnoGen	Tradewinds	Wacker Neuson
base price	80,600.00	124,000.00	85,696.00	85,000.00	72,000.00	82,000.00	73,220.00	102,343.00
downgrade to	60 KW	60 KW	56KW	Not Available for mobile unit	65 KW	61.50	60 KW	58 KW
Deduction	24,300.00	63,000.00	44,870.00		24,500.00	33,000.00	15,580.00	45,544.00
Net Cost	56,300.00	61,000.00	40,826.00	85,000.00	47,500.00	49,000.00	57,640.00	56,859.00

Lowest Bid:

2019 Doosan G70 WCU-34-T4F



Doosan Infracore
Portable Power

Agenda Page 217
1293 Glenway Drive
Statesville, NC 28625
Phone: 704-883-3500
Fax: 704-883-3770
www.doosanportablepower.com

COMPANY:	CORAL SPRINGS IMPROVEMENT DISTRICT		DATE:	7/26/2019
CONTACT:	Curt Diggins		CUST. PO#	QUOTE
ADDRESS:			CUST. ACCT. #	
CITY, ST, ZIP:		FL	PHONE #	(954) 796-6608
EMAIL:	Curtd@fladistricts.com		QUOTE #	PCD71911

SHIP TO:			FOB:	Statesville, NC
ADDRESS:			PREPAID: ()	
CITY, ST, ZIP:			COLLECT: ()	

QUANTITY	DESCRIPTION	LIST PRICE	FSA PRICE
1	G190WCU-3A-T4F TOTAL FSA PRICE (85,277 + 469 FREGIHT)	\$ 133,900	\$ 85,696
	DEDUCT AMOUNT FOR G70WDO-3A-T4F		\$ (44,870)
	TOTAL G70WDO-3A -T4F FSA AMOUNT (40,427 +399 FREIGHT)		\$ 40,826
	CAMLOCKS		\$ 746.88
	WHEEL CHOCKS		\$ 32.00
	KEYED DOOR LOCKS		\$ 53.12
	Lead time: 6 weeks - 8 weeks .		
	Using Florida Sheriffs Assoc Contract (contract # FSA18-VEH16.0)		
	TOTAL EACH		\$ 40,826
	TOTAL QTY		\$ 2

CUSTOMER SIGNATURE:	TAX	\$ -
* Availability subject to change. Please confirm lead time before ordering.	TOTAL	\$ 81,652

IF TAX EXEMPT, FURNISH TAX EXEMPTION CERTIFICATE FOR IR FILES

MEMO: Please note that the leadtime is subject to change.

GENERAL TERMS AND CONDITIONS OF SALE

1. GENERAL

Unless otherwise expressly notified by Doosan Infracore Portable Power (DIPP), in writing, all of CUSTOMER's order acknowledgments by DIPP and all sales made by DIPP to CUSTOMER shall be governed by these general terms and conditions of sale, which supersede and replace, in all respects, any general terms and conditions of purchase proposed by CUSTOMER. DIPP hereby gives notice of its objection to any additional or different terms included in any purchase order or other form submitted by CUSTOMER. Such additional or different terms shall not be included in this contract.

2. PRICES

(a) Unless otherwise specifically stated by DIPP, prices are in accordance with DIPP's price list in effect at the time of delivery, in U.S. dollars, and do not include the cost of special packing, insurance fees, taxes or duties, or any other charges which may be applicable to the sale, export or import of the goods.

(b) All prices are subject to alteration to conform with the published prices in effect at the date of delivery. Such prices are subject to increase by DIPP at any time upon thirty (30) days notice.

3. SHIPMENT

(a) Unless specified by CUSTOMER, DIPP shall select the method of transportation, including place or places of storage, if necessary, in accordance with the shipping conditions current at the time of or during shipment. Upon CUSTOMER's request and subject to availability, DIPP will arrange to obtain ocean freight space, marine insurance (which shall include standard warehouse coverage), war risk insurance and forwarder's services. All such charges shall be payable by CUSTOMER.

(b) All shipments are made for CUSTOMER's account. If shipments are delayed because of delayed payments or insufficient or delayed shipping instructions from CUSTOMER, CUSTOMER shall be charged for storage costs beginning one month after DIPP's notice that the PRODUCTS ordered are ready for shipment and, if PRODUCTS are stored in DIPP's factory, such charge shall be not less than one-half percent (1/2%) per month of the amount invoiced.

(c) Partial shipments may be made and payments therefore shall become due in accordance with the terms hereof, as shipments are made and invoices rendered.

(d) Claims for shortages must be made by CUSTOMER immediately upon receipt of goods.

4. DELIVERY DATE

(a) All dispatch, shipping and delivery dates are estimates only and all such estimates are given on the understanding that CUSTOMER will promptly give all necessary instructions or information to DIPP, including satisfactory assurance to DIPP that CUSTOMER will be able to comply with the agreed terms of payment.

(b) DIPP shall not be liable for loss or damage due to delay in delivery or manufacture resulting from any cause beyond DIPP's reasonable control, including but not limited to, compliance with any government regulations or orders, acts of God, acts or omissions of CUSTOMER, fire, strikes, and factory shut-down. Any delay resulting from any such cause shall constitute cause for extended delivery dates and shall not entitle CUSTOMER to cancel its order.

5. TITLE AND RISK OF LOSS

Title and risk of loss or damage to the PRODUCTS shall pass to CUSTOMER upon tender of delivery F.O.B. DIPP's manufacturing facility, even if transportation or shipping costs are payable by DIPP, unless otherwise agreed upon by the parties, except that a security interest in the PRODUCTS shall remain in DIPP, regardless of mode of attachment to realty or other property, until full payment has been made therefore. CUSTOMER agrees upon request to do all things and acts necessary to perfect and maintain such security interest and shall protect DIPP's interest by adequately insuring the PRODUCTS against loss or damage from any cause wherein DIPP shall be named as a less party.

6. WARRANTY

DIPP warrants each new PRODUCT sold by it hereunder shall be free from defects in material and workmanship for the periods of time specified in the applicable warranties of DIPP for such PRODUCTS, which are incorporated herein by reference. This warranty shall be conditioned upon:

(a) The return of the defective parts (transportation charges prepaid), if DIPP so desires; and

(b) Recognition by DIPP of the warranty claims as justified.

The warranty does not cover normal wear and tear, damages due to overloading or other misuse or due to negligence in service or maintenance, climatic influence or acts of God, nor does the warranty apply to machines or accessories or attachments which have been repaired or altered without DIPP's consent.

DIPP's obligation under the warranty is expressly limited to the replacement or repair of such part or parts which have proven to be defective.

DIPP does not bear any transportation costs of parts or assemblies in connection with warranty service.

Parts and accessories used in the PRODUCTS, but not manufactured by DIPP, shall be subject to the warranty regulations of the manufacturer.

THE FOREGOING WARRANTY IS EXCLUSIVE. DIPP DISCLAIMS ALL OTHER WARRANTIES, EXPRESS OR IMPLIED, INCLUDING ANY IMPLIED WARRANTIES OF MERCHANTABILITY OR FITNESS FOR A PARTICULAR PURPOSE. DIPP SHALL NOT BE LIABLE FOR ANY SPECIAL, INCIDENTAL, INDIRECT OR CONSEQUENTIAL DAMAGES WHATSOEVER, INCLUDING, BUT NOT LIMITED TO, LOSS OR INTERRUPTION OF BUSINESS, LOST PROFITS AND LOSS OF USE, WHETHER BASED ON CONTRACT, WARRANTY, TORT, NEGLIGENCE, STRICT LIABILITY, STATUTE OR OTHERWISE, EVEN IF DIPP HAS BEEN ADVISED OF THE POSSIBILITY OF SUCH DAMAGES. THE TOTAL LIABILITY OF DIPP WITH RESPECT TO THE PRODUCTS FURNISHED HEREUNDER SHALL NOT EXCEED THE PURCHASE PRICE OF THE PRODUCTS UPON WHICH SUCH LIABILITY IS BASED.

7. ASSIGNMENT

DIPP may assign any contract of sale, any individual right thereunder or the receivable resulting therefrom, to any third party without CUSTOMER's consent.

8. PAYMENT

(a) Except as otherwise agreed, standard terms of payment shall be cash or a confirmed irrevocable letter of credit (to be confirmed at a bank acceptable to DIPP), for the entire purchase price payable in full upon delivery of the PRODUCT. Any deviation from such

standard payment terms shall be subject to DIPP's credit approval with respect to the terms of any credit or deferred payment.

(b) In the event of CUSTOMER failing to pay the full amount due on the stated maturity date, CUSTOMER shall pay to DIPP late interest on the unpaid portion of the purchase price at the annual rate of 2% over the prime rate as established by the Federal Reserve in effect on the date of the unpaid invoice for CUSTOMERS located in the United States, Canada or Mexico and five percent (5%) over London Interbank Rate (LIBOR) in effect on the date of the unpaid invoice for all other CUSTOMERS.

(c) It is expressly agreed that in case of nonpayment or delayed payment, the amount due is automatically increased by ten percent (10%) as liquidated damages; in addition, all legal costs (including attorney's fees) incurred by DIPP as a result of CUSTOMER's nonpayment or delayed payment shall be borne by CUSTOMER.

(d) If, prior to payment, CUSTOMER's financial position is, in DIPP's reasonable judgment, deteriorating, DIPP shall, upon its request be granted adequate security.

(e) CUSTOMER alleging a counterclaim may not withhold payment or offset against payments owed to DIPP, unless CUSTOMER's counterclaim is undisputed by DIPP or adjudicated by a final court decision.

(f) If, in the event of an installment sale, CUSTOMER should fail to pay one of the installments within eight (8) days after the stated maturity date, the outstanding aggregate balance shall accelerate and fall due immediately.

(g) DIPP may, in its sole discretion, accept drafts, bills of exchange, promissory notes or other negotiable payment instruments in lieu of payment; however, they constitute payment only when honored by CUSTOMER. Fees and taxes incurred in connection with such instruments or a protest thereof shall be borne by CUSTOMER. In case such instruments are protested or turn out not to be rescountable, DIPP may return them to CUSTOMER and demand immediate cash payment.

(h) DIPP reserves the right to allocate payments made by CUSTOMER against any amounts due from DIPP's business relations with CUSTOMER, irrespective of the purpose of the payment stipulated by CUSTOMER.

9. EXPORT AND RESALE RESTRICTIONS

CUSTOMER will not sell or export the PRODUCTS, or knowingly sell the PRODUCTS for export, to persons or territories prohibited by the export laws of the United States of America.

10. NO WAIVER

No waiver, modification or addition to any of the above terms and conditions will be binding, unless in writing by DIPP, and no waiver of one breach will operate as a waiver of any subsequent breach.

11. CHOICE OF LAW AND JURISDICTION

These terms and conditions shall be construed, and the legal relations between CUSTOMER and DIPP shall be determined, in accordance with the substantive laws of the State of North Carolina for CUSTOMERS located in the United States, Canada or Mexico and in accordance with the substantive laws of Ireland for all other CUSTOMERS, except that any rules with respect to conflict of laws and the United Nations Convention on Contracts for the International Sale of Goods shall not apply. All disputes arising in connection with any order by any CUSTOMER located in the United States, Canada or Mexico hereunder shall be finally settled by arbitration conducted in Charlotte, North Carolina under the Rules of the American Arbitration Association by one or more arbitrators appointed in accordance with such rules. All disputes arising in connection with any order by all other CUSTOMERS hereunder shall be finally settled by arbitration conducted in Dublin, Ireland under the Rules of Conciliation and Arbitration of the International Chamber of Commerce by one or more arbitrators appointed in accordance with such rules.

12. CANCELLATION

CUSTOMER may cancel its order, reduce quantities, revise specifications or extend schedules only by mutual agreement with DIPP as to reasonable and proper cancellation charges which shall take into account expenses already incurred and commitments made by DIPP, and CUSTOMER shall indemnify DIPP against any loss resulting therefrom.

13. PATENTS AND TRADEMARKS

DIPP shall defend, or in its sole discretion, effect settlement of any litigation or claim brought against CUSTOMER so far as based on a contention that any PRODUCT of DIPP's design sold to CUSTOMER by DIPP constitutes an infringement of any patent, or on a contention that the DIPP trademarks infringe upon the rights of third parties, provided that DIPP is notified promptly in writing of such litigation or claim and is given the authority, information and assistance (at DIPP's expense) reasonably requested by DIPP for the defense or settlement of same. In such event DIPP shall pay any final and non-appealable judgment and any costs awarded against CUSTOMER in any such litigation to the extent such judgment or costs relate solely to such alleged patent or trademark infringement. The foregoing states the entire liability of DIPP for patent and trademark infringement by any PRODUCT. CUSTOMER agrees to hold DIPP harmless from all liability and litigation expense based upon alleged infringement of any patent or other intellectual property right resulting from equipment added to or changes made in PRODUCTS after they have left DIPP's plant or based on designs furnished by CUSTOMER.

14. SPECIFICATIONS AND IMPROVEMENTS

Unless expressly otherwise provided, DIPP's specifications concerning PRODUCTS are subject to change by DIPP in the course of manufacture without notice to CUSTOMER. It is DIPP's policy to constantly strive to improve its PRODUCTS. DIPP therefore reserves the right to make changes in design, and other changes, whenever DIPP believes its PRODUCTS will be improved thereby, but without any obligation to incorporate any such changes retroactively.

15. TOOLS

The title and right to and possession of any tools, dies, jigs, fixtures or patterns shall remain in DIPP, whether or not the cost, or any part thereof, is charged to CUSTOMER, unless DIPP otherwise specifically agreed in writing.

Eighteenth Order of Business

A copy of the Water and Sewer Standards will be available for review at the meeting. and is also available on the District website at http://www.csidfl.org/about/5year_permit_index.html

Nineteenth Order of Business

Proposal For Coral Springs Improvement District

(URL: <http://www.csidfl.org/>) Website Type: Medium

Website Accessibility for People with Disabilities as per Nondiscrimination requirements of Title II of the American Disabilities Act (ADA) & WCAG

Date	Version#	Comments	Author
August 13, 2018	1.0	Updated "The Law, ADA and WCAG" section details	VB Joshi, Kristen T
January 10 th , 2019	2.0	Updated conversion and support costs based on discussed scope	VB Joshi
February 25, 2019	2.2	Updated fee-simple pricing and human audit seal	VB Joshi
March 21, 2019	2.3	Added quarterly audit as per insurance requirement	VB Joshi
March 28, 2019	2.4	Updated Annual Maintenance price for ADA support only	VB Joshi
May 7, 2019	2.5	Updated for CDD specific info after conversing with CDD Manager	VB Joshi
May 20, 2019	2.6	Added Human Audit Details	VB Joshi
June 9, 2019	2.7	Added Hosting and Backup to Maintenance	VB Joshi
July 7, 2019	2.8	Updated maintenance - content upload cost added	VB Joshi



Your website gets 2 Compliance Seals

VGlobalTech's Technical Compliance Seal & Human Audit Compliance Seal*

(* Human Audit Contract required)



VGlobalTech is the ADA, WCAG Compliance Expert, with over 250 ADA & WCAG compliant websites created (...and counting) to-date! We have partnered with a non-profit agency to conduct Human Audit and Certification Seal.

Visit <https://vglobaltech.com/website-compliance/> for details.

COPYRIGHT ©: This proposal and the contents within this document are solely created by VGlobalTech team for its customers and cannot be reproduced, copied, modified or distributed (including forwarding to other customers, competitors, web designers etc.) without the written consent of VGlobalTech. VGlobalTech company holds Intellectual Property details along with company software details that must not be shared with others without the written permission of the company. The proposal and software details are customized for the requesting customer and cannot be applied to any other customer / asset / solution. This document does not apply to a case if it is not exclusively sent to you by VGlobalTech upon request.

Any violations are punishable under the law and shall be prosecuted.

Table of Contents

1.0	The Law.....	4
2.0	ADA & WCAG Compliance – Introduction	6
2.1	Common Problems and Solutions in Website Accessibility?.....	7
2.1.1	Problem: Images Without Text Equivalentents	7
2.1.2	Problem: Documents Are Not Posted In an Accessible Format.....	7
2.1.3	Problem: Specifying Colors and Font Sizes	7
2.1.4	Problem: Videos and Other Multimedia Lack Accessible Features.....	7
2.1.5	Web Content Accessibility Guidelines (WCAG)	8
3.0	Pricing.....	10
3.1	Existing Website Remediation / New Website Build:	10
3.2	ADA Compliance Monthly Maintenance and Hosting.....	11
3.3	Quarterly Technical and Human Audit.....	12
	12
4.0	Proposal Acceptance:.....	14
5.0	References:	15

1.0 The Law

Source: http://www.leg.state.fl.us/statutes/index.cfm?App_mode=Display_Statute&URL=0100-0199/0189/Sections/0189.069.html

189.069 Special districts; required reporting of information; web-based public access. —

(1) Beginning on October 1, 2015, or by the end of the first full fiscal year after its creation, each special district shall maintain an official website containing the information required by this section. Each special district shall submit its official website address to the department.

(a) Each independent special district shall maintain a separate website.

(b) Each dependent special district shall be prominently displayed on the home page of the website of the local general-purpose government upon which it is dependent with a hyperlink to such webpages as are necessary to provide the information required by this section. A dependent special district may maintain a separate website providing the information required by this section.

(2)(a) A special district shall post the following information, at a minimum, on the district's official website:

1. The full legal name of the special district.
2. The public purpose of the special district.
3. The name, official address, official e-mail address, and, if applicable, term and appointing authority for each member of the governing body of the special district.
4. The fiscal year of the special district.
5. The full text of the special district's charter, the date of establishment, the establishing entity, and the statute or statutes under which the special district operates, if different from the statute or statutes under which the special district was established. Community development districts may reference chapter 190 as the uniform charter but must include information relating to any grant of special powers.
6. The mailing address, e-mail address, telephone number, and website uniform resource locator of the special district.
7. A description of the boundaries or service area of, and the services provided by, the special district.
8. A listing of all taxes, fees, assessments, or charges imposed and collected by the special district, including the rates or amounts for the fiscal year and the statutory authority for the levy

of the tax, fee, assessment, or charge. For purposes of this subparagraph, charges do not include patient charges by a hospital or other health care provider.

9. The primary contact information for the special district for purposes of communication from the department.

10. A code of ethics adopted by the special district, if applicable, and a hyperlink to generally applicable ethics provisions.

11. The budget of the special district and any amendments thereto in accordance with s.189.016.

12. The final, complete audit report for the most recent completed fiscal year and audit reports required by law or authorized by the governing body of the special district.

13. A listing of its regularly scheduled public meetings as required by s. 189.015(1).

14. The public facilities report, if applicable.

15. The link to the Department of Financial Services’ website as set forth in s. 218.32(1)(g).

16. At least 7 days before each meeting or workshop, the agenda of the event, along with any meeting materials available in an electronic format, excluding confidential and exempt information. The information must remain on the website for at least 1 year after the event.

(b) The department’s website list of special districts in the state required under s. 189.061 shall include a link for each special district that provides web-based access to the public for all information and documentation required for submission to the department pursuant to subsection

2.0 ADA & WCAG Compliance – Introduction

Every individual must have equal access to information whether it is in person service or online. This is a general agreement and understanding of access.

The Internet has dramatically changed the way state and local governments do business. Today, government agencies routinely make much more information about their programs, activities, and services available to the public by posting it on their websites. As a result, many people can easily access this information seven day a week, 24 hours a day.

Many government services and activities are also provided on websites because the public is able to participate in them at any time of day and without the assistance of government personnel. Many government websites offer a low cost, quick, and convenient way of filing tax returns, paying bills, renewing licenses, signing up for programs, applying for permits or funding, submitting job applications, and performing a wide variety of other activities.

The Americans with Disabilities Act (ADA) and, if the government entities receive federal funding, the Rehabilitation Act of 1973 generally require that state and local governments provide qualified individuals with disabilities equal access to their programs, services, or activities unless doing so would fundamentally alter the nature of their programs, services, or activities or would impose an undue burden. One way to help meet these requirements is to ensure that government websites have accessible features for people with disabilities, using the simple steps described in this document. An agency with an inaccessible website may also meet its legal obligations by providing an alternative accessible way for citizens to use the programs or services, such as a staffed telephone information line. These alternatives, however, are unlikely to provide an equal degree of access in terms of hours of operation and the range of options and programs available.

The World Wide Web Consortium (W3C) sets the main international standards for the World Wide Web and its accessibility. W3C created the Web Content Accessibility Guidelines (WCAG 2.0 and 2.1) which are similar to Section 508, but on an international level. WCAG 2.0 and 2.1 requires specific techniques for compliance and is more current than Section 508.

Many countries and international organizations require compliance with WCAG 2.0 and 2.1. The guidelines are categorized into three levels of compliance: A (must support), AA (should support), and AAA (may support). Representatives from the accessibility community around the world participate in the evolution of these guidelines.

Source: <https://www.w3.org/WAI/standards-guidelines/wcag/>

Visit <http://vglobaltech.com/website-compliance/> for more details, do a website compliance check on your website and to download a PDF proposal.

2.1.1 Problem: Images Without Text Equivalents

Solution: Add a Text Equivalent to Every Image

Adding a line of simple HTML code to provide text for each image and graphic will enable a user with a vision disability to understand what it is. Add a type of HTML tag, such as an “alt” tag for brief amounts of text or a “longdesc” tag for large amounts, to each image and graphic on your agency’s website.

The words in the tag should be more than a description. They should provide a text equivalent of the image. In other words, the tag should include the same meaningful information that other users obtain by looking at the image. In the example of the mayor’s picture, adding an “alt” tag with the words “Photograph of Mayor Jane Smith” provides a meaningful description.

In some circumstances, longer and more detailed text will be necessary to convey the same meaningful information that other visitors to the website can see. For example, a map showing the locations of neighborhood branches of a city library needs a tag with much more information in text format. In that instance, where the map conveys the locations of several facilities, add a “longdesc” tag that includes a text equivalent description of each location shown on the map – e.g., “City Center Library, 433 N. Main Street, located on North Main Street between 4th Avenue and 5th Avenue.”

2.1.2 Problem: Documents Are Not Posted In an Accessible Format

Solution: Post Documents in a Text-Based Format

Always provide documents in an alternative text-based format, such as HTML or RTF (Rich Text Format), in addition to PDF. Text-based formats are the most compatible with assistive technologies.

2.1.3 Problem: Specifying Colors and Font Sizes

Solution: Avoid Dictating Colors and Font Settings

Websites should be designed so they can be viewed with the color and font sizes set in users’ web browsers and operating systems. Users with low vision must be able to specify the text and background colors as well as the font sizes needed to see webpage content.

2.1.4 Problem: Videos and Other Multimedia Lack Accessible Features

Solution: Include Audio Descriptions and Captions

Videos need to incorporate features that make them accessible to everyone. Provide audio descriptions of images (including changes in setting, gestures, and other details) to make videos accessible to people who are blind or have low vision. Provide text captions synchronized with the video images to make videos and audio tracks accessible to people who are deaf or hard of hearing.

Understanding the Four Principles of Accessibility

The guidelines and Success Criteria are organized around the following four principles, which lay the foundation necessary for anyone to access and use Web content. Anyone who wants to use the Web must have content that is:

1. **Perceivable** - Information and user interface components must be presentable to users in ways they can perceive.
 - This means that users must be able to perceive the information being presented (it can't be invisible to all of their senses)
2. **Operable** - User interface components and navigation must be operable.
 - This means that users must be able to operate the interface (the interface cannot require interaction that a user cannot perform)
3. **Understandable** - Information and the operation of user interface must be understandable.
 - This means that users must be able to understand the information as well as the operation of the user interface (the content or operation cannot be beyond their understanding)
4. **Robust** - Content must be robust enough that it can be interpreted reliably by a wide variety of user agents, including assistive technologies.
 - This means that users must be able to access the content as technologies advance (as technologies and user agents evolve, the content should remain accessible)

If any of these are not true, users with disabilities will not be able to use the Web.

Under each of the principles are guidelines and Success Criteria that help to address these principles for people with disabilities. There are many general usability guidelines that make content more **usable by all people**, including those with disabilities. However, in WCAG 2.1, we only include those guidelines that address problems particular to people with disabilities. This includes issues that block access or interfere with access to the Web more severely for people with disabilities.

See reference section at the end of this document for more information and websites for ADA, Usability and other important compliance issues and solutions.

VGlobalTech development and business management team shall study these compliance guidelines and with our technical capabilities apply these to make your website accessible, compatible and fully functional for all people, including those with disabilities.

Visit <https://vglobaltech.com/website-compliance/> for details of our compliance process and expertise in this area.

Please see References section for several resources on compliance.

3.0 Pricing

Website Complexity: **Medium Level Websites**

VGlobalTech team shall complete the following critical tasks for client website. All costs below are per website / CDD:

3.1 Existing Website Remediation / New Website Build:

	Task
1.	Remediate existing website / Build new website from start as per Florida Statute Chapter 189 requirements. Ensure ADA & WCAG compliance requirements. Customer shall provide all documents and content required. ALL webpages on the website. Create accessibility document, code review, html updates, plugins / security updates required for ADA and WCAG compliance
2.	Cross-Device Check (Website needs to appear as per ADA standards on Mobile Phones, Tablets, Desktops etc.). Braille Readers, Other assistance technology compatibility
3.	ADA Standards application (as per Section 1 above). ADA.gov, Web Content Accessibility Guidelines (WCAG)
4.	PDF Documents conversion (to Text, HTML etc.) as needed for ADA Compliance / Reader Compliance (up to 2 years of documents shall be converted)
5.	Create a webpage showing websites ADA Compliance efforts
6.	Create customized footer with VGlobalTech's ADA Compliance Seal (valid for 1 year only)
7.	Web Design Total: \$4000/- (one time)

3.2 ADA Compliance Monthly Maintenance and Hosting

Maintenance contract starts after initial conversion is completed (It is critical to maintain compliance as websites get updated):

The Annual Maintenance **DOES NOT** include the quarterly audits proposed in the next section. **Maintenance contract is required for VGlobalTech’s proprietary document conversion software (PDF to RTF) to be used that allows faster, accurate and batch processing for document conversion.**

	Task
1.	Full content upload support to regularly keep site updated (includes all documents, audit reports, agendas, meeting minutes, events etc). Ensure content is in ADA and WCAG compliance for the entire site. Section 508 stipulations (applicable to CDD) and FIA /eGIS insurance requirements are met. These points are very critical to maintain a fully compliant website at all times. Update turnaround time – less than 24 hrs from customer sending the content and documents to be updated to VGT team.
2.	PDF Documents conversion (to Text, HTML etc) as needed (new documents during the maintenance year only) for ADA Compliance / Reader Compliance. VGlobalTech’s proprietary batch conversion software shall be used by our team for faster batch-conversion processing as long as the contract is valid (big time saver that creates compliant documents that can be uploaded to the website). There is no limit on how many documents or pages per documents can be converted per month using VGlobalTech’s software. If Auto conversion fails, VGlobalTech team shall perform manual OCR and conversion within 24 hrs.
3.	Update footer with VGlobalTech’s ADA Compliance Seal (extended for current year)
4.	Website hosting and backups – Premium hosting, unlimited file space, bandwidth, fast website response, regular automated backups, SSL certificates for secure site access (https protocol), 99.9% website uptime:
<p>Total Monthly Maintenance with full content upload, document conversion and Hosting: \$275 / month</p> <p>*support beyond 8 hrs. / month / CDD shall be billed at \$55 / hr. separately (VGlobalTech team shall be responsible to track and report hours exceeded, if any) ***Monthly maintenance must be paid before the 10th of every month</p>	

This audit is as per the Florida Insurance Alliance guidelines. Please check with your insurance agency for specific requirements. **Read more here:** https://vglobaltech.com/wp-content/uploads/2019/03/FIA_ADA_Guidelines-2019-2020.pdf

VGlobalTech has partnered with a local agency for the visually impaired – LightHouse Works. LightHouse has developed a unique program for digital accessibility that is run by visually impaired personnel that are highly skilled in human auditing of websites and software as per the section 508 stipulations. Read more about our partnership here: <https://vglobaltech.com/website-compliance/>

Together we are now able to provide not one but two compliance seals for all our customers:

1. Digital Asset Technical Compliance Seal:



VGlobalTech in-house technical team shall remediate / test the website / software for ADA, WCAG compliance. VGlobalTech's technical design & development team is fully aware of the Americans with Disability Act (ADA), Web Content Accessibility Guidelines (WCAG), **Section 508** of the Rehabilitation Act of 1973 and overall the design principles of a professional, accessible, functional and responsive web design. The entire team has taken dedicated time and efforts to learn these design principles first hand. Our purpose is clear – **Universal, Creative Web design that works for everyone, everywhere and every time!**

2. Human Audit Seal:



LightHouse Works' visually impaired personnel shall actually test the website for compliance as per the section 508 and ADA requirements. The VGlobalTech technical team shall remediate any points discovered by LightHouse team and send the site for re-certification. Upon satisfactory completion LightHouse shall provide the Human Audit Seal that will be specific to the site and the VGlobalTech team shall put the seal on the site. This is an added layer of true Human Audit testing that provides full ADA compliance.

Cost for Audit: \$300 / per audit

- Can be paid yearly for all 4 audits (\$1200) or can be paid per audit every quarter \$300
- Seals renewed every quarter
- Audits are conducted by VGlobalTech and LightHouse Agency together
- Full Audit reports shall be provided

*(1) conference call or in person meetings per month with client to review metrics, results and monthly recaps **unless otherwise noted*

* email and phone communication

*Anything out of the scope of work in the above proposal will be addressed and client will be immediately notified. After notification of additional work, a subsequent quote will be provided to cover that work.

*Client is responsible to adhering to timelines as far as information required to complete the task is concerned. If timelines are not adhered to and exceed 15 business days past the current marketing months, last day, all work will end. A new month with new allocated costs will be presented for future work to commence. No refunds and owed work will be due unless otherwise agreed upon. **An Invoice will be provided once signature approval of this project proposal. Payments will be made to VGLOBALTECH**

*Client is responsible for verifying quality of work, providing feedback, verifying that compliance has been met as required. VGlobalTech team shall not be responsible for any legal ramifications arising from work not done as per external agencies / organizations / associations needs if proper feedback is not provided by the customer. VGlobalTech's work will be in best faith but cannot guarantee all compliance / legal needs since we are not the final authority in the ADA or WCAG compliance area. VGlobalTech shall not be liable for any legal ramifications arising from compliance issues and cannot be held responsible for any legal or other lawsuits.

Refund Policy: The client may halt work and request for a refund within seven days of the date of signing this services agreement by mailing a signed letter to the main address listed on www.VGlobalTech.com website. If client requests a refund within seven days of the date of signing their agreement, they shall be liable to pay for all work completed and will be refunded the remaining balance of the initial payment if billable work has not exceeded a charge that would be greater than client's initial payment. If client requests a refund after the seven days from the date of the signing of the agreement client is liable to pay for all work completed plus an additional 25% of any remaining balance that may still be due. Once line item projects are complete no refunds will be issued. Confidentiality: All information between client and service provider inclusive of technical and business information relating to proprietary ideas, patentable ideas and/or trade secrets, existing and/or contemplated products and services, research and development, production, costs, profit and margin information, finances and financial projections, customers, clients, marketing, and current or future business plans and models, regardless of whether such information is designated as "Confidential Information" at the time of its disclosure and will be treated as such and with absolute confidentiality and will not be shared or used, which will be maintained at all times. The client is not allowed to disclose their price with any third parties. Doing so is in breach of this agreement. All information development will be shared and proprietary information and property between client and service providers.

4.0 Proposal Acceptance:

The VGlobalTech proposed solution and terms have been accepted by the customer and the VGlobalTech can proceed with the project. All payments shall be made according to this agreement.

Select Proper Option Below, Sign and Date, Return to contact@vglobaltech.com:

Option1: Website only

Section 3.1: One time (website conversion and compliance cost):

Option2: Website and Monthly Maintenance w/ Hosting

Section 3.1: One time (website conversion and compliance cost)

+

Section 3.2 ADA Compliance Monthly Maintenance and Hosting

Option3: Website and Quarterly Audits

Section 3.1: One time (website conversion and compliance cost)

+

Section 3.3 Quarterly Technical and Human Audit Testing

Option4: Website, Monthly Maintenance w/ Hosting and Quarterly Audits

Section 3.1: One time (website conversion and compliance cost)

+

Section 3.2 ADA Compliance Monthly Maintenance and Hosting

+

Section 3.3 Quarterly Technical and Human Audit Testing

Signatures:

For Customer

Date

VB Joshi

For VGlobalTech

Date

ADA Best Practices Tool Kit for State and Local Governments:

<https://www.ada.gov/pcatoolkit/chap5toolkit.htm>

U.S. Department of Justice, Civil Rights Division, Disability Rights Section

<https://www.ada.gov/websites2.htm>

Web design Standards: <https://www.w3schools.com/>

Web Content Accessibility Guidelines (WCAG) <https://www.w3.org/TR/WCAG21/>

VGlobalTech Web Content Accessibility Implementation and Checkpoints:

<http://vglobaltech.com/website-compliance/>



Twentieth Order of Business

20A.

Notice of Meetings
Coral Springs Improvement District

The Board of Supervisors of the Coral Springs Improvement District will hold their meetings for Fiscal Year 2020 in the District Offices, 10300 N. W. 11 Manor, Coral Springs, Florida at **4:00 p.m.** on the third Monday of each month unless otherwise specified below:

October 21, 2019
November 18, 2019
December 16, 2019
January 27, 2020 (Fourth Monday)
February 24, 2020 (Fourth Monday)
March 16, 2020
April 20, 2020
May 18, 2020
June 15, 2020
July 20, 2020
August 17, 2020
September 21, 2020

In addition to the regular meeting schedule, one or more Supervisors may attend weekly staff meetings/workshops every Tuesday morning at 9:00 a.m. at the District Offices.

There may be occasions when one or more Supervisors will participate by telephone. Meetings may be continued to a date and time certain, which will be announced at the meeting. Any interested person can attend the meeting at the above location and be fully informed of the discussions taking place. A scheduled meeting may be cancelled by the BOS based on the business needs of the District.

Any person requiring special accommodations at this meeting because of a disability or physical impairment should contact the management firm, Inframark, at (954) 603-0033 at least two calendar days prior to the meeting. If you are hearing or speech impaired, please contact the Florida Relay Service at 711 for aid in contacting the District Office.

Each person who decides to appeal any decision made by the Board with respect to any matter considered at the meeting is advised that person may need to ensure that a verbatim record of the proceedings is made, including the testimony and evidence upon which such appeal is to be based.

Kenneth Cassel
District Manager

20B.

Globaltech, Inc.
CSID Engineer's Report
August 19, 2019

PROJECTS UNDER CONTRACT

WA #131- HSP 7 Modifications – Closeout

- Approved by Board – 1/22/18
- Pump installed 5/31/19
- Project complete.

WA #133 - Facility Arc-Flash Study – In Progress

- Revised Draft Report submitted 10/30 – under review.
- Conditional Assessment submitted 11/16 – under review.
- Vulnerability Assessment delivered 11/28.
- Delivered Final Report 5/08/19
- Globaltech to prepare an amendment to Final Report addressing 4 off site wells
- Completion mid-August

WA#137 – High Service Pump 1 & 2 Improvement – in Progress

- Approved by Board – 3/21/19
- Preparing submittals for valves
- HSP 1 removed 5/31 and picked up by Hudson Pump on 6/07/19.
- Pump 1 scheduled to be returned and installed mid-September.
- Completion date – 3/01/20

WA #139 – Generator Diesel Fuel Line Replacement – In Progress

- Approved by Board – 4/26/18
- Permit application submitted week of 2/09/19.
- Permit issued 5/08/19
- Project ready to commence – waiting on Cypress Construction to mobilize.
- Completion Date 8/30/19

WA #140 – Dual Zone Monitor Well Construction – Closeout

- Approved by Board – 6/18/18
- MW-4 completed 6/06/19.
- YBI abandonment of monitoring tubes 7/17/19
- Completion date 7/19/19.
- Addressing punch list items

WA #141 – Plant D Repair – In Progress

- Approved by Board – 4/26/18
- Demolition completed 8/15/18
- Mechanical equipment (rake arm, center column, center cage, and drive) delivered & installed.
- Mechanical startup 7/20/19
- Waiting to apply Xypex coating to clarifier floor followed by two-week cure.
- Startup / completion date - 8/30/19.

Globaltech, Inc.
CSID Engineer's Report
August 19, 2019

PROJECTES UNDER CONTRACT (Cont.)

WA #143 – Site 12 Canal Bank Restoration – Closeout

- Approved by Board 6/18/18
- Restoration work completed 11/02/18
- Home owner provided contract with independent fencing contractor. Payment will be made upon submission of permit application.
- Complete – August 2019

WA #149 – High Service Pump Building Isolation Valve Replacements – Closeout

- Approved by Board 10/16/18
- Project Complete
- Amendment for additional work presented on 8/19/19 agenda

WA#151 – ORP Analyzer – On 11/26/18 Board – Closeout

- Approved by Board 11/26/18
- Startup performed 6/28/19
- Amendment returning allowance on 8/19/19 agenda

WA#152 – Deep Injection Well Operating Permits – Closeout

- Approved by Board 11/26/18
- Application was submitted January 25, 2019
- Draft Permit issued 6/12/19
- Advertising the intent to issue permit.
- Final permit will be issued in August
- Completion date – 8/16/19

WA#156 – Production Well 8 Redevelopment – Closeout

- Well returned to service by 7/05/19
- Project Complete
- Addressing restoration activities with Parks Department

WA#158 – 4MG Ground Storage Tank Repair and Improvements – Closeout

- Approved by Board – 3/21/19
- Final inspection to occur by 6/21/19.
- Project Complete

**Globaltech, Inc.
CSID Engineer's Report
August 19, 2019**

Work Authorizations Under Development

WA#149 Amendment 1 – HSP Building Valve Replacement – 8/19/19 Agenda

WA#151 Amendment 1 – ORP Analyzer – 8/19/19 Agenda

WA#159 – High Service Pump 7 Low Pressure Auto-start – Under development

WA#162 – Production Well 9 VFD and Electrical Improvements – 8/19/19 Agenda

WA#163 – Production Well 5 Redevelopment – 8/19/19 Agenda

WA#164 – High Service Pump Building Drainage Improvements – Under development

20C.



August Report to the Board of Supervisors for the Water Plant

Report Includes Updates through 8/7/2019

Piggyback opportunity for well maintenance with AMPS

The Martin County contract that we are currently piggybacking off of for well maintenance with AMPS expires this month. They have a new contract in place with the City of Sunrise which was awarded on 2/12/19 and is good for 3 years with two optional one year renewals. This Sunrise contract includes a chemical free method for well maintenance. This will eliminate the injection of chlorine into our wellfield on a regular basis which is a huge plus as membranes cannot tolerate chlorine. The difference in cost is very minimal. If approved we would like to continue piggybacking off of this contract as long as it is renewed.

Well 5 rehab (WA 163)

AMPS and Connect Consulting were finally able to complete a static and dynamic video on this well. The report came back stating that the well is producing sand, as expected and needs to be airlifted and jetted (rehab). A work authorization in the amount of \$94,500 is being presented at this meeting for this work. As opposed to placing 80 hours' worth of development in the work authorization we placed 40 of that in the allowance so that they have to come back to us at the end of 40 and explain why another 40 is necessary. The allowance also includes \$7,500 for potential unexpected expenses.

Automatic Transfer Switch Failure

During our routine monthly generator run in June it was noticed that the transfer switch did not transfer over to the generator as it should have. The FPL breaker in our ATS is malfunctioning and cannot be repaired or simply replaced due to its age. A new ATS panel has been ordered through Globaltech and will be here around the week of 8/12. It will take 3-5 days to install. The total for this replacement is \$147,000. In the meantime we have rented a temporary diesel engine driven high service pump which will automatically start up and pump water out to the District during a low pressure scenario. Due to how loud the engine is when running we requested a sound barrier be installed around it since there are a few homes nearby. This has already ran on several occasions and performed as expected. The total cost for this setup is \$56,000.

Four million gallon tank repairs (WA 158)

Crom has finished all of the contracted work on this tank as well as the safety railing on the other two. In our opinion this project is complete however Crom has requested additional funding from Globaltech for work they feel was beyond their scope. We disagree and are going back and forth on this now.

Underground valve replacement amendment (WA 149)

Work authorization 149, which was for the replacement of several underground valves on the North side of the high service pump building, has been completed. Due to having to split this into two phases in order to avoid a precautionary boil water notice there were a few additional expenses required including re mobilizations, an additional line stop, and some additional fittings and labor.

Installation of VFD on well 9 (WA 162)

We have asked Globaltech to prepare a work authorization to be presented at this month's meeting requesting the installation of a variable frequency drive on well 9. Now that the specific capacity is significantly higher following the recent rehab of this well we have much more flexibility with flowrates on this well which will provide greater operational control of our raw water inflow. This will also help with electrical demand as the motor will be able to be turned down. The proposed WA is in the amount of \$96,999.

Four million gallon tank repairs (WA 158)

Crom has finished all of the contracted work on this tank as well as the safety railing on the other two. In our opinion this project is complete however Crom has requested additional funding from Globaltech for work they feel was beyond their scope. We disagree and are going back and forth on this now.

High service pump 7 replacement (WA 131)

Globaltech and the pump supplier installed the new pump on 5/31. The pump is performing as expected although the motor did experience a small oil leak and we are obtaining quotes now for the repair. After evaluating the age of the motor (26yrs old) it is looking like it makes more sense to replace it than to repair it and add the auto start components that we were looking at and budgeted for. This is a key tool in avoiding precautionary boil water notices.

Well 8 rehabilitation (WA 156)

Globaltech, Connect Consulting, and Centerline drilling completed this rehab project on 6/24. The recommended clearance samples were collected and the well was placed back in service. They were able to achieve 20 gpm/ft of drawdown (specific capacity) from this well. It was yielding 12gpm/ft before they started. This is a significant improvement and according to Globaltech and the Connect the well will produce 750 gpm without issue like our others.

Projects with Globaltech

- Replacement of high service pump building automatic transfer switch- Underway
- Well 5 rehab- WA 163 being presented at August meeting
- High service pump #7 auto start at low pressure- WA 159 to be presented in September
- Replacement of high service pumps 1&2's impellers- WA approved in March. Underway
- Underground diesel tank transfer lines upgrade- WA 139 approved in April 18. Underway
- ORP probe installation- WA 152 approved in November. Completed
- Feed motor bearing replacement – WA 161 approved in April. Completed
- 4 million gallon storage tank repairs- WA 158 approved in March. Completed
- Well 8 rehabilitation- WA 156 approved in December. Amendment approved in February. Completed
- Relocation of post treatment injection points- Avoided
- Mitigation of draining issues near HSP building- WA to be presented in September
- Installation of a VFD on well 9- WA 162 to be presented in August

Water Loss

The graph below compares the water loss % in 2018 vs 2019. So far this year we are at an average of 13.29% loss and the goal is to be below 10% by the end of December. At the end of July last year we were at an average of 16.01% so we are still on track to be in much better shape than last year.

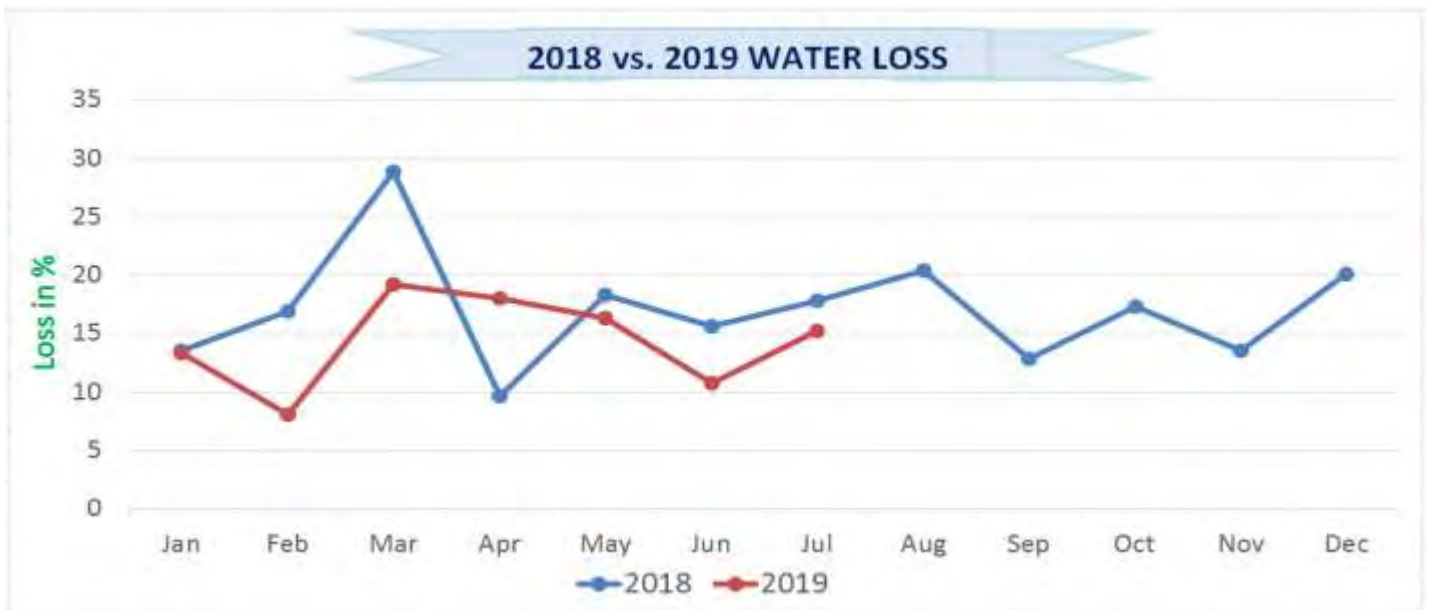

C.S.I.D. DISTRIBUTION-BILLED-LOSS %

MONTH	DIST.	BILLED	%
Dec-18	118.06	94.35	20.08
Jan-19	116.96	101.365	13.33
Feb-19	103.74	95.393	8.05
Mar-19	116.01	93.65	19.27
Apr-19	116.89	95.82	18.03
May-19	118.08	98.83	15.30
Jun-19	114.89	102.56	10.73
Jul-19	114.95	97.37	15.29
Aug-19			#DIV/0!
Sep-19			#DIV/0!
Oct-19			#DIV/0!
Nov-19			#DIV/0!
Dec-19			#DIV/0!
2019 Avg.	114.50	97.86	13.29
2019 Tot.	801.52	684.99	
2018 Tot.	1417.21	1173.56	15.94

Total % loss -1.25% (unbilled auth. Consumption)

Total % loss -1.25% (unbilled auth. Consumption)

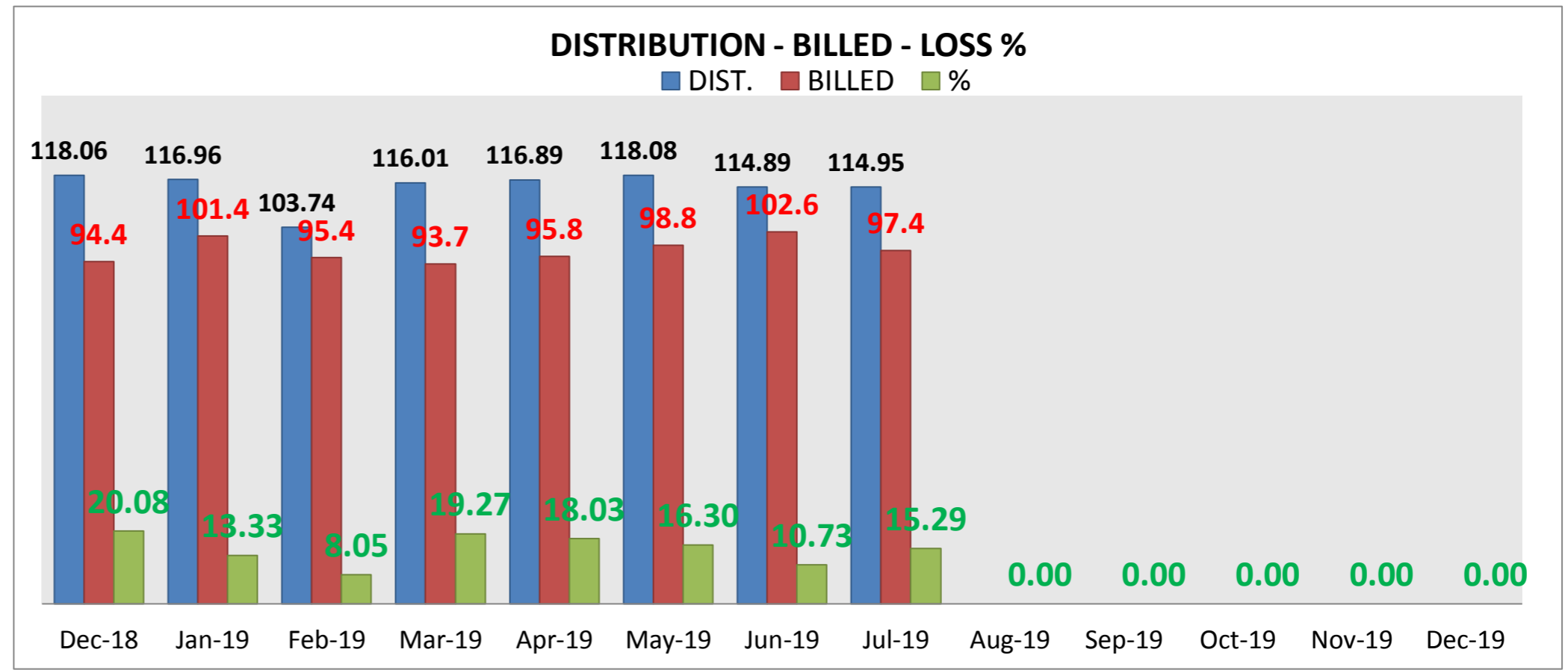

Wastewater Plant Operations Report for July 2019

Monthly Influent average flow for July was 4.628 MGD.

Monthly R.O. Concentrate average flow was 0.682 MGD.

Monthly DW Injection average flow was 5.765 MGD.

Finished 3rd Quarter Sour Test

Working on Annual DW Injection Report.

Corrective and preventive maintenance in all plants.

Ongoing Projects.

WA #141 – Plant D Repairs

After pouring the floor in D Plant small cracks developed throughout the floor of the tank. Globaltech decided to apply a two part epoxy coating to the floor to cover and seal the cracks. On day two of applying the epoxy heavy rains lifted and peeled the coating they had just applied. Globaltech scrapped the epoxy that lifted and peeled and is waiting for drier days to reapply and finish the rest. Globaltech is also working on a platform for ladder entry into the tank. This platform was built incorrectly and is being redesigned. We still have a 2 week dry time once epoxy coating is finished before we can test the construction and fill the tank.

WA #140 – Monitoring Well #4 Construction

Monitoring Well #4 UMZ and LMZ has been completed but still waiting on labeling, testing results and O&M manuals from Globaltech. Latest word from Rick Olson is two weeks out. Nico from Global Tech still needs to come back and complete the punch out list on the SCADA. A new pump was installed in the LMZ of MW #3. But today it developed a problem with water flowing out of an

electrical conduit line so it is now out of service. David McNabb has been notified and will be getting Globaltech to respond.



Coral Springs Improvement District

Drainage Report August 19, 2019

Board of Supervisors Meeting

- Current canal levels averages are 6.89 NGVD 29 in the east basin and 6.90 NGVD 29 in the west basin as of this report.
Total rainfall recorded for July was 6.35 inches.
Rainfall recorded for August is 3.56 inches at the time of this report
Rainfall recorded to date for the year is 30.01 inches at the time of this report
- Field spray activities are on schedule, despite of being down 1 employee due to injury.
Dept. Manager is assisting in field activities to ensure not to fall far behind normal operations.
- Mowing is on schedule, pictures are captured during each activity

AVG. BASIN LEVEL AND TOTAL RAINFALL

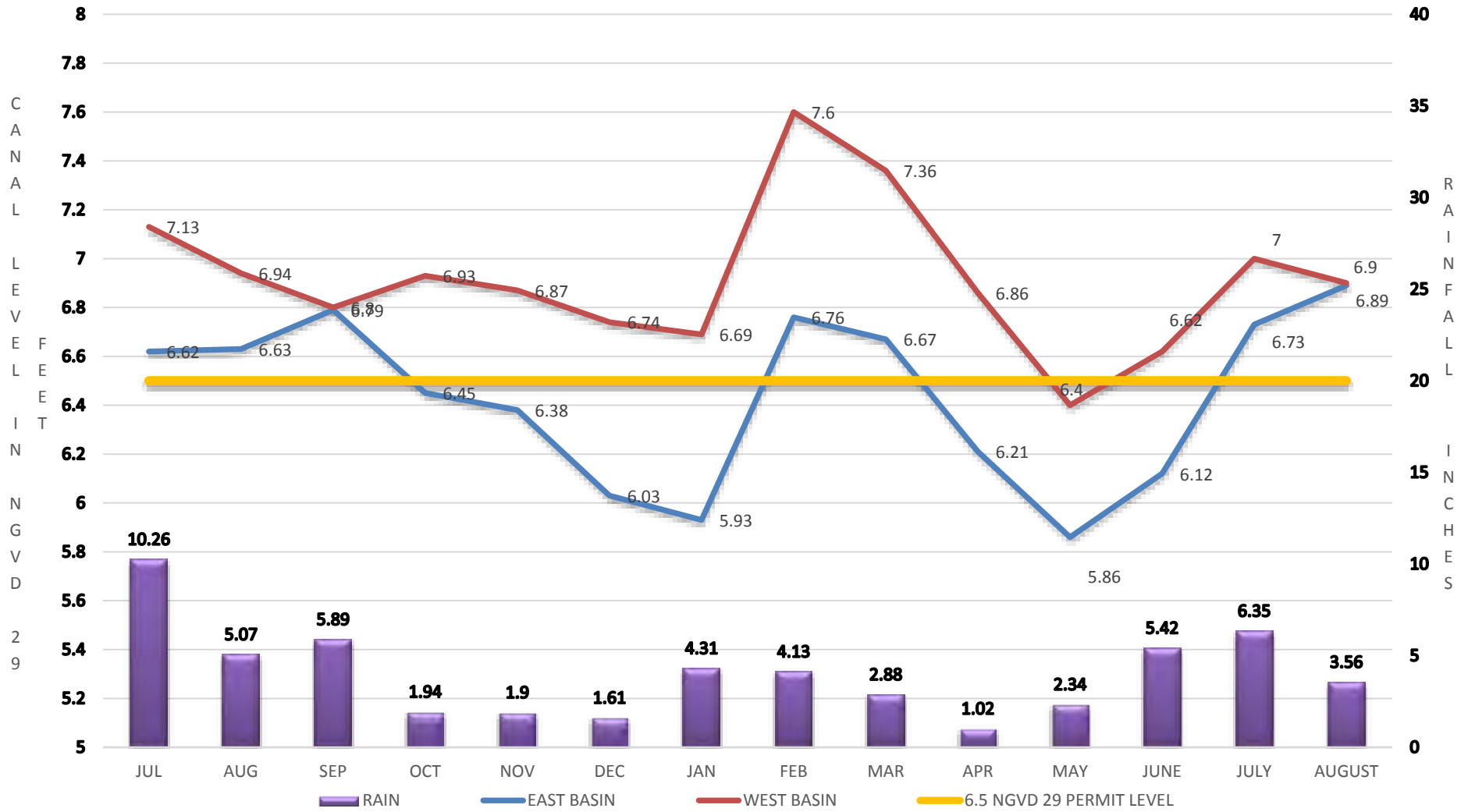

Iguana Management: July 2018 through July 2019

Iguana's controlled

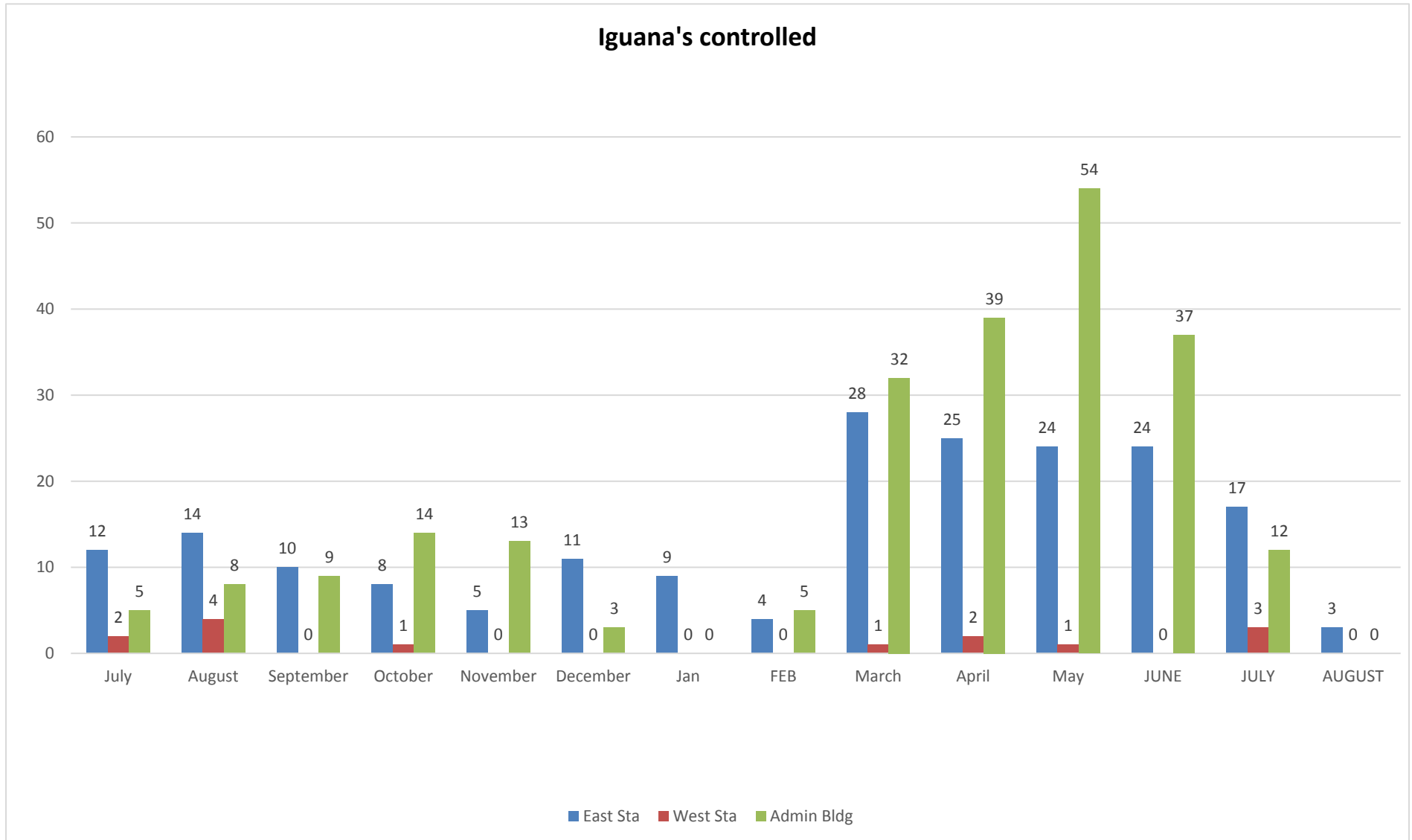



Coral Springs Improvement District
10800 N.W. 11TH BLVD Coral Springs, FL 33071

Water Distribution and Wastewater Collection

Department Report

8-19-19 board Meeting

Prepared by: Curtis Dwiggins

- There were 9 repaired water service breaks in the month of July.
- Trio Development Corp has completed the rehabilitation project for lift station 14. The station is back online and operating as expected.
- The Field Department is requesting the purchase of two 56KW portable generators from the FSA cooperative purchasing program. The lowest bidder who offers a product that meets our specification is Doosan. It is included in the agenda for your consideration
- Garber has updated their expected completion date of our Sierra 2500 Utility truck. at the time this report was written, the expected completion date was 8/9/19, So I will have more info at the meeting
- The field department has made good progress in our valve monument program, with very little interruption or inconvenience to our customers.
- Also for your consideration is a program that deals directly with managing backflow prevention and control programs. Backflow Solutions Inc. (BSI) is an online, cloud based service which enables municipalities to better control their programs with the services they provide. The cost is minimal to the District, but is fee based (currently \$12.95) to the customer, or the certifying plumber directly, as a fee for filing test reports annually.
- I have included in this report the service break trend. It shows significant reduction in water breaks, post service replacement program.

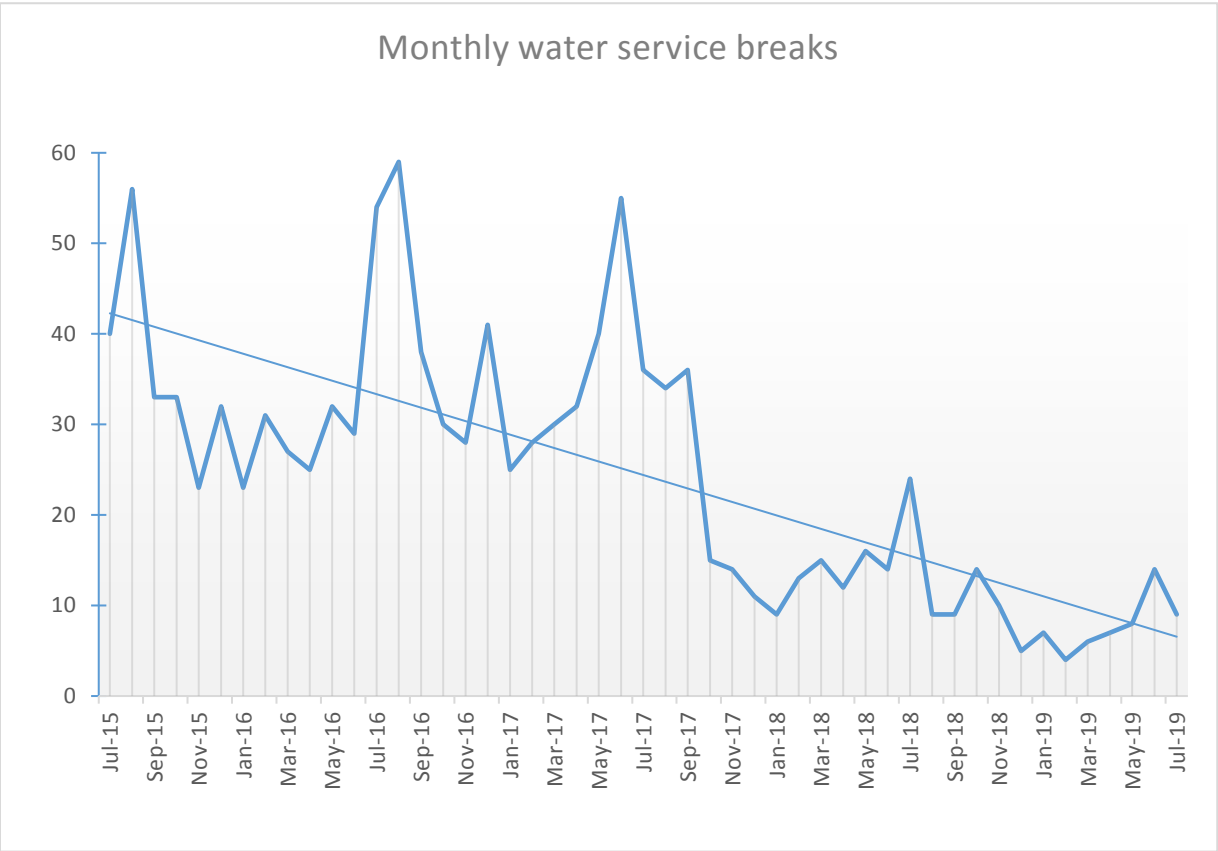



Coral Springs Improvement District
10800 N.W. 11TH Manor Coral Springs, FL 33071

Maintenance Department Report (Pedro V.)

Water Department:

- In coordination with Global Tech and WP to solve the transfer switch problem in HSP Building. The last week we were with FPL personnel in site.
- In coordination with Delta Control to solve the problem of the diesel transfer pumps electrical panel, #1 WP main generator.
- The 250 HP process motor #1 the bearings was modified and is in normal operation.
- Waiting for parts to repair the process room cooling fan system.
- Normal PM in equipment.

Wastewater Department:

- PM and lubrication in different equipment and blowers oil replacement.
- Works in the field, painting, etc.
- Works in the belt press feed pumps and solving some problems in the drain lines.
- Troubleshooting in different electrical equipment and solving the situations.
- Working with the 404 VFD cooling fans. We try to repair the old fans, but one of them has to be replaced, new spare parts are expected to arrive soon.

Field Department:

- Works with the lake pump.

Drainage Department

- Helping Shawn with the chemical exhaust fans replacement. The work was completed, old equipment was replaced by new cheaper chemical resistant equipment, was necessary electrical and mechanical modification to be installed.